

Mini-cylinders Series 16, 23, 24 and 25



Series 16: \varnothing 8, 10, 12 mm - non-magnetic
 Series 23: \varnothing 16, 20, 25 mm - magnetic, auto-cushioned
 Series 24: \varnothing 16, 20, 25, 32 mm - magnetic
 Series 25: \varnothing 16, 20, 25, 32 mm - magnetic, cushioned



- » Single and double-acting
- » In compliance with ISO 6432
- » Stainless steel rod and barrel
- » Anodized aluminium end-blocks
- » Cushioning types: mechanical with bumper, pneumatic auto-cushioning, adjustable pneumatic cushioning

Series 16, 23, 24 and 25 mini-cylinders are designed according to ISO 6432. It is possible to choose from three different types of cushioning: mechanical (standard bumper on Series 16 and 24), adjustable pneumatic cushioning (Series 25) and pneumatic auto-cushioning (Series 23). This last version, thanks to a patented system, automatically adjusts the cushioning in order to provide optimal deceleration during the entire cushioning phase. The cylinder enjoys smooth, jolt-free movement, reducing vibrations and noise, while also guaranteeing high reliability and constant performance over time.

The adopted technical solutions and the choice of materials have provided the basis for a complete range of versatile and very reliable mini-cylinders. They are suitable to be used in a multitude of industrial applications, especially where operating conditions undergo changes over time like for example wear of machine components. Various mounting accessories are available to fix the cylinders in different ways.

GENERAL DATA

Type of construction	crimped
Operation	single-acting and double-acting
Design	ISO 6432 (\varnothing 8, 10, 12, 16, 20, 25)
Materials	anodized aluminium end-caps - stainless steel barrel and rod, aluminium piston - NBR/PU seals, other parts: see the coding example
Brackets	rod end - flange - feet - trunnion
Stroke min - max	\varnothing 8, 10 : 10 - 250 mm; \varnothing 12 : 10 - 300 mm; \varnothing 16 : 10 - 600 mm; \varnothing 20, 25, 32 : 10 - 1000 mm
Bores	Series 16: \varnothing 8, 10, 12 - Series 23: \varnothing 16, 20 and 25 - Series 24, 25: \varnothing 16, 20, 25 and 32
Operating temperature	0°C ÷ 80°C (with dry air -20°C)
Operating pressure	1 ÷ 10 bar (double-acting); 2 ÷ 10 bar (single-acting)
Fluid	filtered air in class 7.8.4 according to ISO 8573-1. If lubricated air is used, it is recommended to use oil ISO VG32. Once applied the lubrication should never be interrupted.
Speed	10 ÷ 1000 mm/sec (without load)

STANDARD STROKES FOR MINICYLINDERS

- = Double-acting
- ✕ = Single-acting

STANDARD STROKES															
Series	∅	10	25	40	50	80	100	125	160	200	250	300	320	400	500
16	10	■✕	■✕	■✕	■✕	■	■	■	■	■	■				
16	12	■✕	■✕	■✕	■✕	■	■	■	■	■	■				
24	16	■✕	■✕	■✕	■✕	■	■	■	■	■	■	■	■	■	■
24	20	■✕	■✕	■✕	■✕	■	■	■	■	■	■	■	■	■	■
24	25	■✕	■✕	■✕	■✕	■	■	■	■	■	■	■	■	■	■
24	32	■✕	■✕	■✕	■✕	■	■	■	■	■	■	■	■	■	■
23/25	16	■	■	■	■	■	■	■	■	■	■	■	■	■	■
23/25	20	■	■	■	■	■	■	■	■	■	■	■	■	■	■
23/25	25	■	■	■	■	■	■	■	■	■	■	■	■	■	■
25	32	■	■	■	■	■	■	■	■	■	■	■	■	■	■

CODING EXAMPLE

24	N	2	A	16	A	100	
24	SERIES 16 = non magnetic, with mechanical cushioning 23 = magnetic, auto-cushioning 24 = magnetic, with mechanical cushioning 25 = magnetic, adjustable cushioning						
N	VERSION N = standard						
2	OPERATION 1 = single-acting, front spring, no cushion (only for series 16, 24) 2 = double-acting 3 = double-acting, through-rod 7 = single-acting, through-rod (only for series 16, 24)				PNEUMATIC SYMBOLS CS02 (s. 16) - CS06 (s. 24) CD01 (s. 16) - CD08 (s. 24) - CD23 (s. 23) - CD09 (s. 25) CD05 (s. 16) - CD12 (s. 24) - CD24 (s. 23) - CD13 (s. 25) CS04 (s. 16) - CS10 (s. 24)		
A	MATERIALS A = rolled stainless steel AISI 303 rod (∅32 AISI 420B) - stainless steel AISI 304 tube - anodized AL end-blocks						
16	BORE 08 = 8 mm (only for series 16) 10 = 10 mm (only for series 16) 12 = 12 mm (only for series 16) 16 = 16 mm (only for series 23, 24 e 25) 20 = 20 mm (only for series 23, 24 e 25) 25 = 25 mm (only for series 23, 24 e 25) 32 = 32mm (only for series 24 e 25)						
A	CONSTRUCTION A = Nose nut Mod. V + Piston rod lock nut Mod. U RL = cylinder with rod lock (only for ∅20 - ∅25)						
100	STROKE (see graph) = standard V = rod seal in FKM W = all seals in FKM, +130°C (only for series 25: ∅16, 20, 25) (_ _) = extended rod _ _ _ mm						

PNEUMATIC SYMBOLS

The pneumatic symbols which have been indicated in the CODING EXAMPLE are shown below.

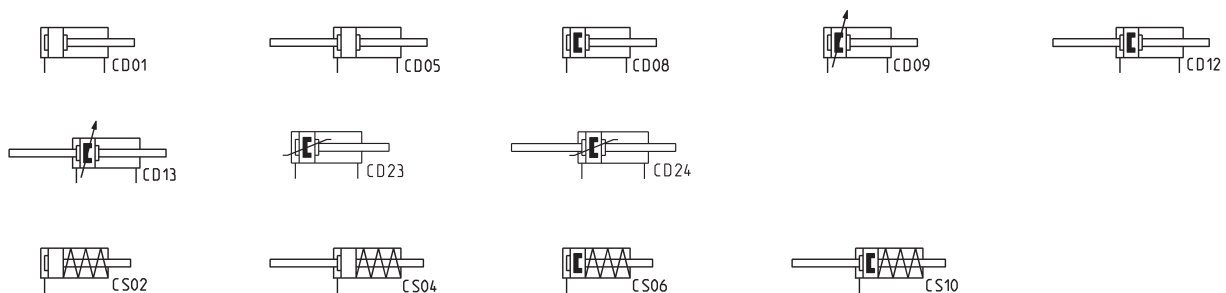

ACCESSORIES FOR MINICYLINDERS SERIES 16 - 23 - 24 - 25

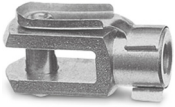

Rod fork end Mod. G



Swivel ball joint Mod. GA



Piston rod socket joint Mod. GY



Self aligning rod Mod. GK



Coupling piece Mod. GKF



Piston rod lock nut Mod. U



Nose nut Mod. V



Rear trunnion bracket Mod. I



Foot mount Mod. B



Front/rear flange mount Mod. E



Proximity switches Mod. CST



Proximity switches Mod. CSH



Proximity switches Mod. CSG



Adapters Mod. S-CST-02



Guides Mod. 45NUT



Guides Mod. 45NHT



Guides Mod. 45NHB

All accessories are supplied separately, except for piston rod lock nut Mod. U and nose nut Mod. V

SERIES 16-24: GRAPH SHOWING THE LOADS OF THE CYLINDER SPRINGS

Check the force of the spring on the graph, according to the size chosen.

F = Force of the spring (N)
 X = Cylinder stroke (mm)

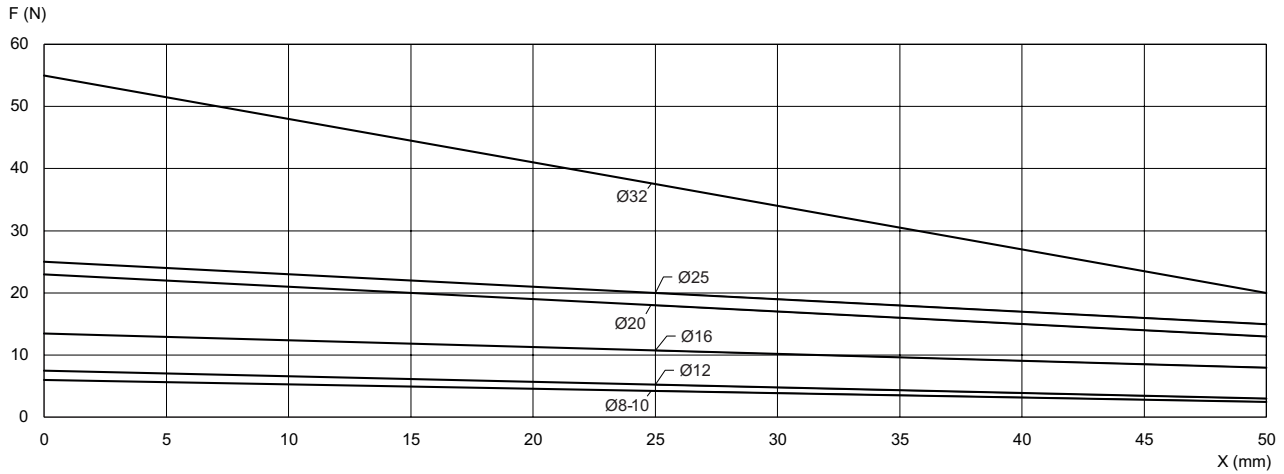

SERIES 23: APPLICABLE MASS ACCORDING TO THE CYLINDER'S SPEED

CHOICE OF THE CYLINDER

- 1) Choose the right size according to the force needed in the application
- 2) Check on the graph if the working conditions, mass and speed intersect at a point below the curve that corresponds to the size chosen

m = mass applied to the cylinder (kg)
 v = speed applied to the cylinder (m/s)

Example:
 Diameter = 20 mm; Max speed = 0,4 m/s; Applicable mass = 6kg;

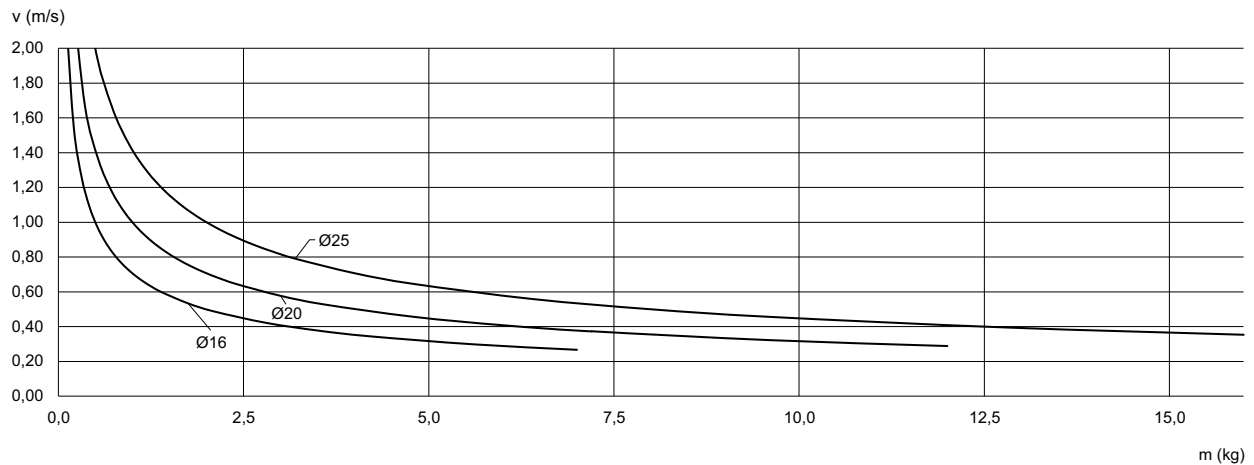

Series 16, 23, 24 and 25 mini-cylinders

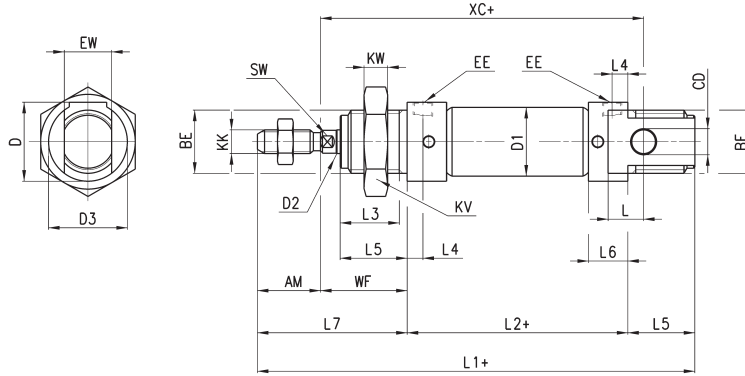

+ = add the stroke

DIMENSIONS																											
Series	∅	EW	KW	BE	KK	CD	\varnothing D1	EE	\varnothing D2	L1+	XC+	L2+	AM	L3	L4	L5	L	WF	L6	L7	KV	SW	D	D3	front/rear cushion stroke		
16	8	8	7	M12x1,25	M4x0,7	4	9,3	M5	4	86	64	46	12	10	4,5	12	6	16	9	28	19	-	15	15	-		
16	10	8	7	M12x1,25	M4x0,7	4	11,3	M5	4	86	64	46	12	10	4,5	12	6	16	9	28	19	-	15	15	-		
16	12	12	8	M16x1,5	M6x1	6	13,3	M5	6	105	75	50	16	15	4,5	17	9	22	9	38	24	5	20,5	20	-		
23	16	12	8	M16x1,5	M6x1	6	17,3	M5	6	111	82	56	16	15	5,5	17	9	22	12	38	24	5	20,5	20	10		
24-25	16	12	8	M16x1,5	M6x1	6	17,3	M5	6	111	82	56	16	15	5,5	17	9	22	10	38	24	5	20,5	20	10		
23-24-25	20	16	10	M22x1,5	M8x1,25	8	21,3	G1/8	8	132	95	68	20	18	8	20	12	24	16	44	32	7	27	27	15		
23-24-25	25	16	10	M22x1,5	M10x1,25	8	26,5	G1/8	10	141,5	104	69,5	22	20	8	22	12	28	16	50	32	9	27	27	16		
24-25	32	26	8	M30x1,5	M10x1,25	12	33,6	G1/8	12	139	105	69	20	19	7,5	22	13	28	15	48	-	10	36,5	35	18		

Series 16, 23, 24 and 25 mini-cylinders with through-rod

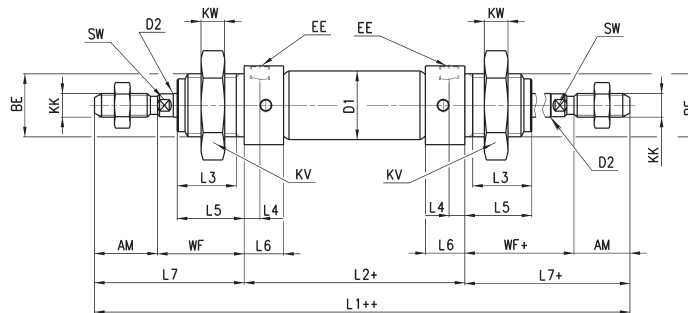

+ = add the stroke once
++ = add the stroke twice

DIMENSIONS																											
Series	∅	KW	BE	KK	\varnothing D1	EE	\varnothing D2	L1++	L2+	AM	L3	L4	L5	WF+	L6	L7+	KV	SW	front/rear cushion stroke								
16	8	7	M12x1,25	M4x0,7	9,3	M5	4	102	46	12	10	4,5	12	16	9	28	19	-	-								
16	10	7	M12x1,25	M4x0,7	11,3	M5	4	102	46	12	10	4,5	12	16	9	28	19	-	-								
16	12	8	M16x1,5	M6x1	13,3	M5	6	126	50	16	15	4,5	17	22	9	38	24	5	-								
23	16	8	M16x1,5	M6x1	17,3	M5	6	132	56	16	15	5,5	17	22	12	38	24	5	10								
24-25	16	8	M16x1,5	M6x1	17,3	M5	6	132	56	16	15	5,5	17	22	10	38	24	5	10								
23-24-25	20	10	M22x1,5	M8x1,25	21,3	G1/8	8	156	68	20	18	8	20	24	16	44	32	7	15								
23-24-25	25	10	M22x1,5	M10x1,25	26,5	G1/8	10	169,5	69,5	22	20	8	22	28	16	50	32	9	16								
24-25	32	8	M30x1,5	M10x1,25	33,6	G1/8	12	165	69	20	19	7,5	22	28	15	48	-	10	18								

Series 23 - 24 - 25 mini-cylinders with rod lock (Mod. RLC)



+ = add the stroke

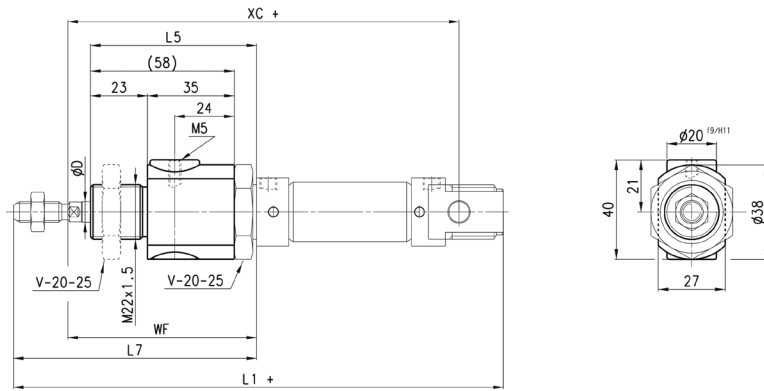

DIMENSIONS								
Series	∅	⁶⁷ D	WF	L5	L7	XC+	L1+	F (N)
23-24-25	20	8	74	70	94	145	182	300
23-24-25	25	10	76	70	98	152	189,5	400

Rod fork end Mod. G

ISO 8140
Material: zinc-plated steel.

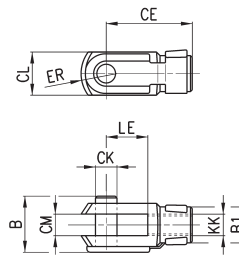
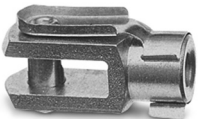

DIMENSIONS										
Mod.	∅	CL	ER	CE	B	CM	∅CK	LE	KK	∅B1
G-8-10	8-10	8	5	16	11	4	4	8	M4x0,7	8
G-12-16	12-16	12	7	24	16	6	6	12	M6x1	10
G-20	20	16	10	32	22	8	8	16	M8x1,25	14
G-25-32	25-32	20	12	40	26	10	10	20	M10x1,25	18

Swivel ball joint Mod. GA



ISO 8139
Material: zinc-plated steel.

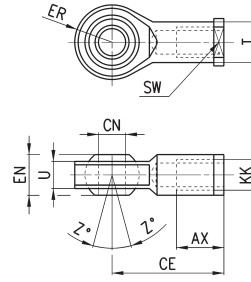

DIMENSIONS											
Mod.	∅	$\varnothing_{CN}^{(H7)}$	U	EN	ER	AX	CE	KK	∅T	Z	SW
GA-8-10	8-10	5	6	8	9	10	27	M4x0.7	9	6.5°	9
GA-12-16	12-16	6	7	9	10	12	30	M6x1	10	6.5°	11
GA-20	20	8	9	12	12	16	36	M8x1.25	12.5	6.5°	14
GA-32	25-32	10	10.5	14	14	20	43	M10x1.25	15	6.5°	17

Piston rod socket joint Mod. GY



ISO 8139
Material: zama and zinc-plated steel.

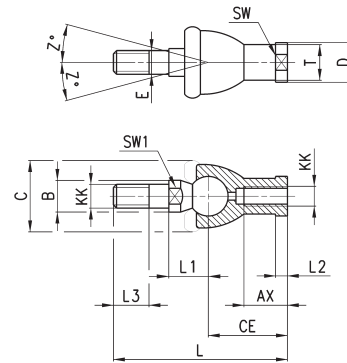

DIMENSIONS																
Mod.	∅	Z	E	SW	\varnothing_T	\varnothing_D	\varnothing_C	\varnothing_B	KK	L3	SW1	L1	L	CE	AX	L2
GY-12-16	12-16	15	6	11	10	13	20	10	M6x1	11	8	12,2	55	28	15	5
GY-20	20	15	8	14	12,5	16	24	12	M8x1,25	12	10	16	65	32	16	5
GY-32	25-32	15	10	17	15	19	28	14	M10x1,25	15	11	19,5	74	35	18	6,5

Self aligning rod Mod. GK

Material: zinc-plated steel.

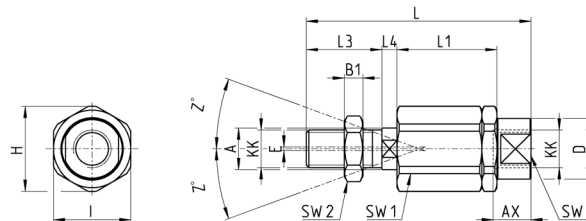

DIMENSIONS																	
Mod.	∅	H	I	Z	\varnothing_A	KK	E	L	L3	L4	L1	B1	SW2	SW1	AX	SW	\varnothing_D
GK-12-16	12-16	14.5	13	3	6	M6x1	1	35	11	2.5	17.5	4	10	5	12.5	7	8.5
GK-20	20	19	17	4	8	M8x1,25	2	57	21	5	26	4	13	7	16	11	12.5
GK-25-32	25-32	32	30	4	14	M10x1,25	2	71.5	20	7.5	35	5	17	12	22	19	22

Coupling piece Mod. GKF



Material: zinc-plated steel.

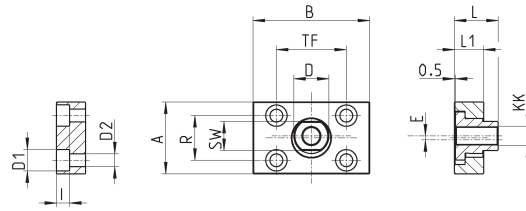

DIMENSIONS															
Mod.	∅	∅ D1	l	∅ D2	A	R	SW	B	TF	∅ D	E	L	L1	KK	
GKF-20	20	5,5	-	-	30	20	13	35	25	14	1,5	22,5	10	M8x1,25	
GKF-25-32	25-32	11	6,8	6,6	37	23	15	60	36	18	2	22,5	15	M10x1,25	

Piston rod lock nut Mod. U



ISO 4035
Material: zinc-plated steel.

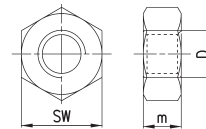

DIMENSIONS				
Mod.	∅	SW	m	D
U-8-10	8-10	7	3	M4X0,7
U-12-16	12-16	10	4	M6X1
U-20	20	13	5	M8X1,25
U-25-32	25-32	17	6	M10X1,25

Nose nut Mod.V



ISO 4035
V-8-10 / V-20-25 / V 42-32
not according standard.
Material: zinc-plated steel

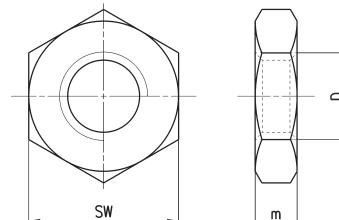

DIMENSIONS				
Mod.	∅	D	m	SW
V-8-10	8-10	M12X1,25	7	19
V-12-16	12-16	M16X1,5	8	24
V-20-25	20-25	M22X1,5	10	32
V-42-32	32	M30x1,5	8	-

Rear trunnion bracket Mod. I



Supplied with:
1x zinc-plated steel rear trunnion
1x stainless steel clevis pin
2x steel Seeger

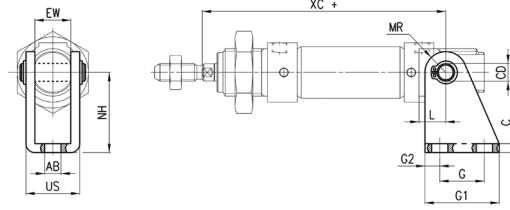

+ = add the stroke

DIMENSIONS													
Mod.	∅	EW	∅AB	US	NH	XC+	MR	L	G2	G	G1	CD	C
I-8-10	8-10	8	4,5	13,1	24	64	5	6	3,5	12,5	20	4	2,5
I-12-16	12	12	5,5	18,1	27	75	7	9	5	15	25	6	3
I-12-16	16	12	5,5	18,1	27	82	7	9	5	15	25	6	3
I-20-25	20	16	6,6	24,1	30	95	10	12	6	20	32	8	4
I-20-25	25	16	6,6	24,1	30	104	10	12	6	20	32	8	4
I-24-32	32	26	7	34	33	105	11,5	13	7	24	38	12	4

Foot mount Mod. B



Feet and nose nut material: zinc-plated steel.

Supplied with:
2x feet
1x nose nut mod. V

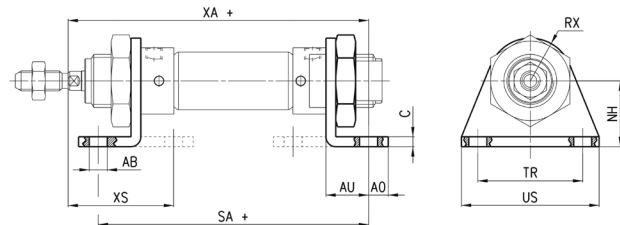

+ = add the stroke

DIMENSIONS												
Mod.	∅	∅AB	XS	XA+	SA+	AO	AU	C	RX	TR	US	NH
B-8-10	8-10	4,5	24	72,5	67	4,5	10,5	2,5	10	25	35	16
B-12-16	12	5,5	32	82,5	76	6	13	3	13	32	42	20
B-12-16	16	5,5	32	91	82	6	13	3	13	32	42	20
B-20-25	20	6,6	36	108	100	8	16	4	20	40	54	25
B-20-25	25	6,6	40	113,5	101,5	8	16	4	20	40	54	25
B-24-32	32	7	40	113	101	7	16	4	20,5	58	66	28

Front/rear flange mount Mod. E



Material: zinc-plated steel.

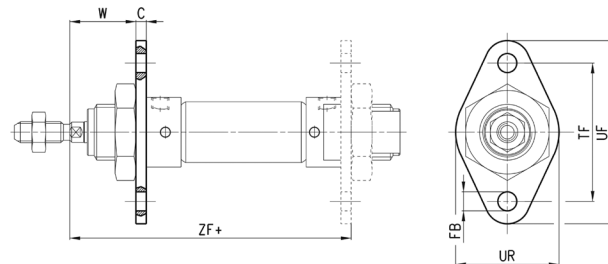

+ = add the stroke

DIMENSIONS									
Mod.	∅	W	C	ZF+	FB	UF	TF	UR	
E-8-10	8-10	13,5	2,5	64,5	4,5	40	30	25	
E-12-16	12	19	3	75	5,5	53	40	30	
E-12-16	16	19	3	81	5,5	53	40	30	
E-20-25	20	20	4	96	6,6	66	50	40	
E-20-25	25	24	4	101,5	6,6	66	50	40	
E-24-32	32	23	5	102	6,6	68	52	50	

Magnetic proximity switches with 2 or 3 wire cable for T-slot



Note for 2-wire switches Mod. CST-220, CST-220-5:
in case of polarity reversing the sensor will still be operating, but the LED diode won't turn on.

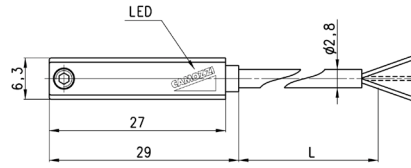

Further details can be found in the "Proximity switch" chapter.

Mod.	Operation	Connections	Voltage	Output	Max. current	Max Load	Protection	L = length cable
CST-220	Reed	2 wires	10 ÷ 110 V AC/DC-230 V AC	-	250 mA	10 VA / 8W	None	2 m
CST-220-5	Reed	2 wires	10 ÷ 110 V AC/DC-230 V AC	-	250 mA	10 VA / 8 W	None	5 m
CST-220-12	Reed	2 wires	10 ÷ 110 V AC/DC-230 V AC	-	250 mA	10 VA / 8W	None	12 m
CST-220EX	Reed	2 wires	10 ÷ 110 V AC/DC-230 V AC	-	250 mA	10 VA / 8W	None	2 m
CST-220-5EX	Reed	2 wires	10 ÷ 110 V AC/DC-230 V AC	-	250 mA	10 VA / 8W	None	5 m
CST-220-12EX	Reed	2 wires	10 ÷ 110 V AC/DC-230 V AC	-	250 mA	10 VA / 8W	None	12 m
CST-232	Reed	3 wires	5 ÷ 30 V AC/DC	PNP	250 mA	10 VA / 8 W	Against polarity reversing	2 m
CST-232-5	Reed	3 wires	5 ÷ 30 V AC/DC	PNP	250 mA	10 VA / 8 W	Against polarity reversing	5 m
CST-232EX	Reed	3 wires	5 ÷ 30 V AC/DC	PNP	250 mA	10 VA / 8W	Against polarity reversing	2 m
CST-232-5EX	Reed	3 wires	5 ÷ 30 V AC/DC	PNP	250 mA	10 VA / 8W	Against polarity reversing and overvoltage	5 m
CST-332	Magnetostrictive	3 wires	10 ÷ 27 V DC	PNP	100 mA	6 W	Against polarity reversing and overvoltage	2 m
CST-332-5	Magnetostrictive	3 wires	10 ÷ 27 V DC	PNP	100 mA	6 W	Against polarity reversing and overvoltage	5 m
CST-332EX	Magnetostrictive	3 wires	10 ÷ 27 V DC	PNP	100 mA	6 W	Against polarity reversing and overvoltage	2 m
CST-332-5EX	Magnetostrictive	3 wires	10 ÷ 27 V DC	PNP	100 mA	6 W	Against polarity reversing and overvoltage	5 m
CST-432	Reed	3 wires	5 ÷ 30 V AC/DC	PNP-NC	250 mA	10 VA / 8 W	Against polarity reversing	2 m
CST-432-5	Reed	3 wires	5 ÷ 30 V AC/DC	PNP-NC	250 mA	10 VA / 8 W	Against polarity reversing	5 m
CST-432EX	Reed	3 wires	5 ÷ 30 V AC/DC	PNP-NC	250 mA	10 VA / 8 W	Against polarity reversing	2 m
CST-432-5EX	Reed	3 wires	5 ÷ 30 V AC/DC	PNP-NC	250 mA	10 VA / 8 W	Against polarity reversing	5 m
CST-532	Hall effect	3 wires	10 ÷ 27 V DC	PNP	100 mA	6 W	Against polarity reversing and overvoltage	2 m
CST-532-5	Hall effect	3 wires	10 ÷ 27 V DC	PNP	100 mA	6 W	Against polarity reversing and overvoltage	5 m
CST-532EX	Hall effect	3 wires	10 ÷ 27 V DC	PNP	100 mA	6 W	Against polarity reversing and overvoltage	2 m
CST-532-5EX	Hall effect	3 wires	10 ÷ 27 V DC	PNP	100 mA	6 W	Against polarity reversing and overvoltage	5 m

Magnetic proximity switches with M8 3-pin connector for T-slot



Note for 2-wire switch Mod. CST-250N:
in case of polarity reversing the sensor will still be operating, but the LED diode won't turn on.

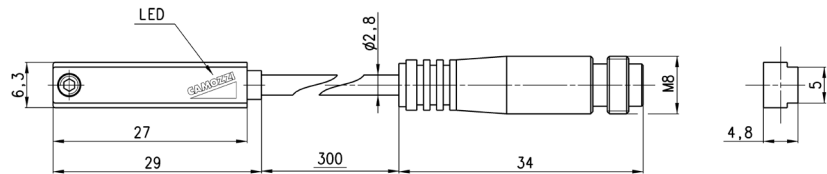
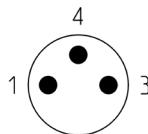

Cable length: 0.3 m

Further details can be found in the "Proximity switch" chapter.

Mod.	Operation	Connection	Voltage	Output	Max. current	Max load	Protection
CST-250N	Reed	2 wires M8 male 3 pin	10 ÷ 110 V AC/DC	-	250 mA	10 VA / 8 W	None
CST-250NEX	Reed	2 wires M8 male 3 pin	10 ÷ 110 V AC/DC	-	250 mA	10 VA / 8 W	None
CST-262	Reed	3 wires M8 male 3 pin	5 ÷ 30 V AC/DC	PNP	250 mA	10 VA / 8 W	Against polarity reversing
CST-262EX	Reed	3 wires M8 male 3 pin	5 ÷ 30 V AC/DC	PNP	250 mA	10 VA / 8 W	Against polarity reversing
CST-362	Magnetostrictive	3 wires M8 male 3 pin	10 ÷ 27 V DC	PNP	100 mA	6 W	Against polarity reversing and overvoltage
CST-362EX	Magnetostrictive	3 wires M8 male 3 pin	10 ÷ 27 V DC	PNP	100 mA	6 W	Against polarity reversing and overvoltage
CST-562	Hall effect	3 wires M8 male 3 pin	10 ÷ 27 V DC	PNP	100 mA	6 W	Against polarity reversing and overvoltage
CST-562EX	Hall effect	3 wires M8 male 3 pin	10 ÷ 27 V DC	PNP	100 mA	6 W	Against polarity reversing and overvoltage

Magnetic proximity switches with 2 or 3 wire cable for H-slot



Note for 2-wire switches Mod. CSH-223-2, CSH-223-5, CSH-221-2, CSH-221-5:
in case of polarity reversing the sensor will still be operating, but the LED diode won't turn on.

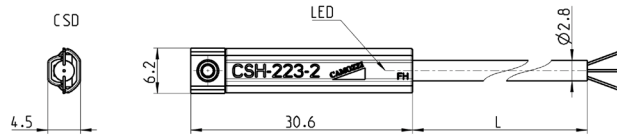

Further details can be found in the "Proximity switch" chapter.

Mod.	Operation	Connection	Voltage	Output	Max current	Max load	Protection	L = cable length
CSH-223-2	Reed	2 wires	10 ÷ 30 V AC/DC	-	250 mA	10 VA / 8 W	Against polarity reversing	2 m
CSH-223-5	Reed	2 wires	10 ÷ 30 V AC/DC	-	250 mA	10 VA / 8 W	Against polarity reversing	5 m
CSH-223-10	Reed	2 wires	10 ÷ 30 V AC/DC	-	250 mA	10 VA / 8 W	Against polarity reversing and overvoltage	10 m
CSH-223-2EX	Reed	2 wires	10 ÷ 30 V AC/DC	-	250 mA	10 VA / 8 W	Against polarity reversing and overvoltage	2 m
CSH-223-5EX	Reed	2 wires	10 ÷ 30 V AC/DC	-	250 mA	10 VA / 8 W	Against polarity reversing	5 m
CSH-223-10EX	Reed	2 wires	10 ÷ 30 V AC/DC	-	250 mA	10 VA / 8 W	Against polarity reversing	10 m
CSH-221-2	Reed	2 wires	30 ÷ 230 V AC - 30 ÷ 110 V DC	-	250 mA	10 VA / 8 W	Against polarity reversing	2 m
CSH-221-5	Reed	2 wires	30 ÷ 230 V AC - 30 ÷ 110 V DC	-	250 mA	10 VA / 8 W	Against polarity reversing	5 m
CSH-221-2EX	Reed	2 wires	30 ÷ 230 V AC - 30 ÷ 110 V DC	-	250 mA	10 VA / 8 W	Against polarity reversing	2 m
CSH-221-5EX	Reed	2 wires	30 ÷ 230 V AC - 30 ÷ 110 V DC	-	250 mA	10 VA / 8 W	Against polarity reversing	5 m
CSH-233-2	Reed	3 wires	10 ÷ 30 V AC/DC	PNP	250 mA	10 VA / 8 W	Against polarity reversing	2 m
CSH-233-5	Reed	3 wires	10 ÷ 30 V AC/DC	PNP	250 mA	10 VA / 8 W	Against polarity reversing	5 m
CSH-233-2EX	Reed	3 wires	10 ÷ 30 V AC/DC	PNP	250 mA	10 VA / 8 W	Against polarity reversing	2 m
CSH-233-5EX	Reed	3 wires	10 ÷ 30 V AC/DC	PNP	250 mA	10 VA / 8 W	Against polarity reversing	5 m
CSH-334-2	Magneto-resistive	3 wires	10 ÷ 27 V DC	PNP	250 mA	6 W	Against polarity reversing and overvoltage	2 m
CSH-334-5	Magneto-resistive	3 wires	10 ÷ 27 V DC	PNP	250 mA	6 W	Against polarity reversing and overvoltage	5 m
CSH-334-2EX	Magneto-resistive	3 wires	10 ÷ 27 V DC	PNP	250 mA	6 W	Against polarity reversing and overvoltage	2 m
CSH-334-5EX	Magneto-resistive	3 wires	10 ÷ 27 V DC	PNP	250 mA	6 W	Against polarity reversing and overvoltage	5 m
CSH-433-2	Reed NC	3 wires	10 ÷ 30 V AC/DC	PNP	250 mA	10 VA / 8 W	Against polarity reversing and overvoltage	2 m
CSH-433-5	Reed	3 wires	10 ÷ 30 V AC/DC	PNP-NC	250 mA	10 VA / 8 W	Against polarity reversing	5 m
CSH-433-2EX	Reed	3 wires	10 ÷ 30 V AC/DC	PNP-NC	250 mA	10 VA / 8 W	Against polarity reversing	2 m
CSH-433-5EX	Reed	3 wires	10 ÷ 30 V AC/DC	PNP-NC	250 mA	10 VA / 8 W	Against polarity reversing	5 m

Magnetic proximity switches with M8 3-pin connector for H-slot



Note for 2-wire switch Mod. CSH-253:
in case of polarity reversing the sensor will still be operating, but LED diode won't turn on.

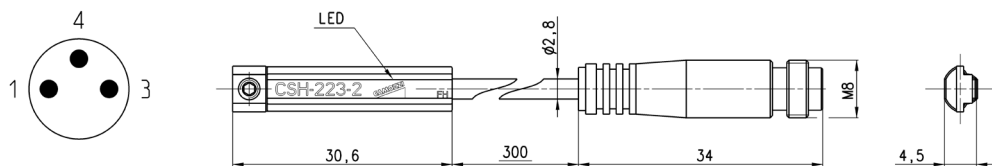

Cable length: 0.3 m

Further details can be found in the "Proximity switch" chapter.

Mod.	Operation	Connection	Voltage	Output	Max current	Max load	Protection
CSH-253	Reed NO	2 wires M8 male 3 pin	10 ÷ 30 V AC/DC	-	250 mA	10 VA / 8 W	Against polarity reversing
CSH-253EX	Reed NO	2 wires M8 male 3 pin	10 ÷ 30 V AC/DC	-	250 mA	10 VA / 8 W	Against polarity reversing
CSH-263	Reed NO	3 wires M8 male 3 pin	10 ÷ 30 V AC/DC	PNP	250 mA	10 VA / 8 W	Against polarity reversing
CSH-263EX	Reed NO	3 wires M8 male 3 pin	10 ÷ 30 V AC/DC	PNP	250 mA	10 VA / 8 W	Against polarity reversing
CSH-364	Magneto-resistive	3 wires M8 male 3 pin	10 ÷ 27 V DC	PNP	250 mA	6 W	Against polarity reversing and overvoltage
CSH-364EX	Magneto-resistive	3 wires M8 male 3 pin	10 ÷ 27 V DC	PNP	250 mA	6 W	Against polarity reversing and overvoltage
CSH-463	Reed NC	3 wires M8 male 3 pin	10 ÷ 30 V AC/DC	PNP	250 mA	10 VA / 8 W	Against polarity reversing
CSH-463EX	Reed NC	3 wires M8 male 3 pin	10 ÷ 30 V AC/DC	PNP	250 mA	10 VA / 8 W	Against polarity reversing

Magnetic proximity switches, ATEX "II 3 GD" certified, T-slot, straight

New



Note for 2-wire switches Mod. CSG-223-2-EX, CSG-223-5-EX, CSG-324-2-EX, CSG-324-5-EX:
in case of polarity reversing the sensor will still be operating, but the LED diode won't turn on.

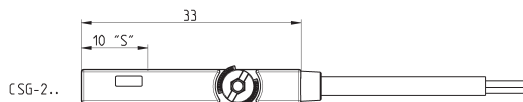
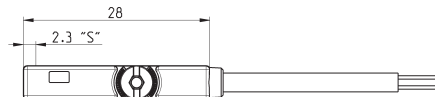

Further details can be found in the "Proximity switch" chapter.

Mod.	Operation	Connection	Voltage	Output	Max current	Max load	Protection
CSG-223-2-EX	Reed NO	2 wires	5 ÷ 30 V AC/DC	-	100 mA	3 W	IP67
CSG-223-5-EX	Reed NO	2 wires	5 ÷ 30 V AC/DC	-	100 mA	3 W	IP67
CSG-233-2-EX	Reed NO	3 wires	10 ÷ 30 V AC/DC	-	500 mA	10 W	IP67
CSG-233-5-EX	Reed NO	3 wires	10 ÷ 30 V AC/DC	-	500 mA	10 W	IP67
CSG-324-2-EX	Magneto-resistive NO	2 wires	10 ÷ 28 V DC	-	50 mA	1.5 W	IP67
CSG-324-5-EX	Magneto-resistive NO	2 wires	10 ÷ 28 V DC	-	50 mA	1.5 W	IP67
CSG-334-2-EX	Magneto-resistive NO	3 wires	10 ÷ 28 V DC	PNP	200 mA	5.5 W	IP67
CSG-334-5-EX	Magneto-resistive NO	3 wires	10 ÷ 28 V DC	PNP	200 mA	5.5 W	IP67
CSG-534-2-EX	Magneto-resistive NO	3 wires	10 ÷ 28 V DC	NPN	200 mA	5.5 W	IP67
CSG-534-5-EX	Magneto-resistive NO	3 wires	10 ÷ 28 V DC	NPN	200 mA	5.5 W	IP67
CSG-734-2-EX	Magneto-resistive NC	3 wires	10 ÷ 28 V DC	NPN	200 mA	5.5 W	IP67
CSG-734-5-EX	Magneto-resistive NC	3 wires	10 ÷ 28 V DC	NPN	200 mA	5.5 W	IP67
CSG-634-2-EX	Magneto-resistive NC	3 wires	10 ÷ 28 V DC	PNP	200 mA	5.5 W	IP67
CSG-634-5-EX	Magneto-resistive NC	3 wires	10 ÷ 28 V DC	PNP	200 mA	5.5 W	IP67

Magnetic proximity switches, UL certified, T-slot, straight

New



Note for 2-wire switches Mod. CSG-223-2-UL, CSG-223-5-UL, CSG-324-2-UL, CSG-324-5-UL:
in case of polarity reversing the sensor will still be operating, but the LED diode won't turn on.

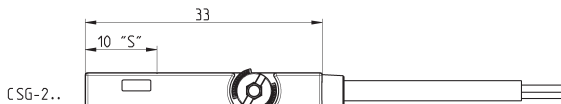
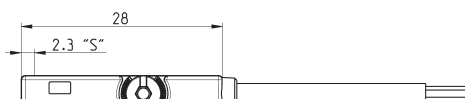

Further details can be found in the "Proximity switch" chapter.

Mod.	Operation	Connection	Voltage	Output	Max current	Max load	Protection
CSG-223-2-UL	Reed	2 wires	5 ÷ 30 V AC/DC	-	60 mA	1.8 W	IP67
CSG-223-5-UL	Reed	2 wires	5 ÷ 30 V AC/DC	-	60 mA	1.8 W	IP67
CSG-223-10-UL	Reed	2 wires	5 ÷ 30 V AC/DC	-	60 mA	1.8 W	IP67
CSG-233-2-UL	Reed	3 wires	10 ÷ 30 V AC/DC	-	100 mA	3 W	IP67
CSG-233-5-UL	Reed	3 wires	10 ÷ 30 V AC/DC	-	100 mA	3 W	IP67
CSG-233-10-UL	Reed	3 wires	10 ÷ 30 V AC/DC	-	100 mA	3 W	IP67
CSG-324-2-UL	Magneto-resistive	2 wires	10 ÷ 28 V DC	-	40 mA	1.2 W	IP67
CSG-324-5-UL	Magneto-resistive	2 wires	10 ÷ 28 V DC	-	40 mA	1.2 W	IP67
CSG-334-2-UL	Magneto-resistive	3 wires	10 ÷ 28 V DC	PNP	100 mA	3 W	IP67
CSG-334-5-UL	Magneto-resistive	3 wires	10 ÷ 28 V DC	PNP	100 mA	3 W	IP67
CSG-534-2-UL	Magneto-resistive	3 wires	10 ÷ 28 V DC	NPN	100 mA	3 W	IP67
CSG-534-5-UL	Magneto-resistive	3 wires	10 ÷ 28 V DC	NPN	100 mA	3 W	IP67

Adapters Mod. S-CST-02...21 for Series CST-CSH-CSG sensors

Materials:
- technopolymer (S-CST-02÷04)

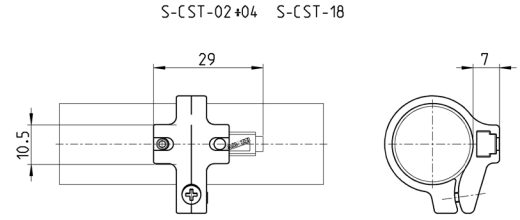

SERIES 16, 23, 24 AND 25 MINI-CYLINDERS

Mod.	Cylinders Series	∅
S-CST-02	23, 24, 25	16
S-CST-03	23, 24, 25	20
S-CST-04	23, 24, 25	25
S-CST-18	23, 24, 25	32

Further details can be found in the "Proximity switch" chapter.

Guides Mod. 45NUT for cylinders Series 16, 24, 25



Suitable for cylinders Series 16, 24 and 25 DIN/ISO 6432, \varnothing 12 and 16. These guides do not need lubrication. For applicable loads see graph 1.

Cylinders \varnothing 12 and \varnothing 16 use the same guides.

Supplied with:
1x fixing nut.

Draw note:
+ = add the stroke

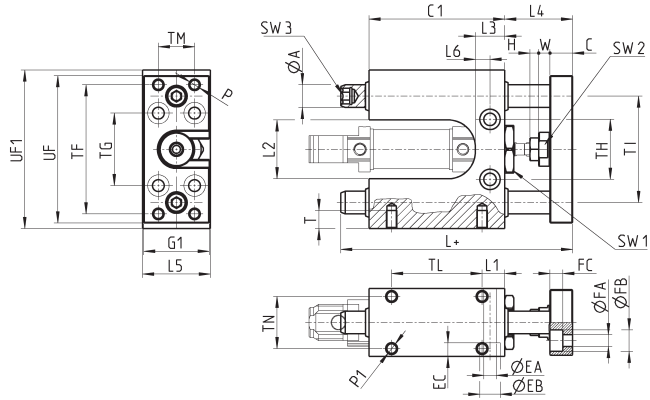

DIMENSIONS																																		
\varnothing	TF	TG	TH	TI	TM	TL	TN	UF1	UF	G1	\varnothing A	C1	H	W	C	L	L1	L2	L3	L4	L5	L6	P	P1	T	\varnothing EA	\varnothing EB	EC	\varnothing FA	\varnothing FB	FC	SW1	SW2	SW3
12	57	32	26,5	47	16	40	23	70	65	29	10	60	4	5	10	102,5	10	26	13	30	30	6,5	M5	M5	8	5,5	9	5,7	5,5	9,5	5,7	21	13	6
16	57	32	26,5	47	16	40	23	70	65	29	10	60	4	5	10	102,5	10	26	13	30	30	6,5	M5	M5	8	5,5	9	5,7	5,5	9,5	5,7	21	13	6

Guides Mod. 45NUT for cylinders Series 24, 25



Suitable for cylinders Series 24 and 25 DIN/ISO 6432, \varnothing 20 and 25. These guides do not need lubrication.

For applicable loads see graph 1.

Supplied with:
1x fixing nut.

Draw note:
+ = add the stroke

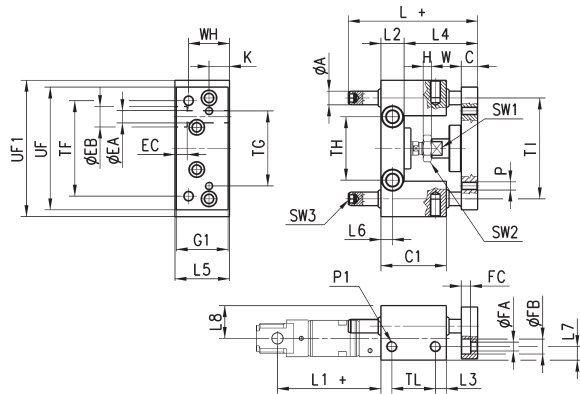

DIMENSIONS																																		
\varnothing	TF	TG	TH	TI	TL	UF1	UF	G1	\varnothing A	WH	C1	H	W	C	K	L	L1	L2	L3	L4	L5	L6	L7	L8	P	P1	\varnothing EA	\varnothing EB	EC	\varnothing FA	\varnothing FB	FC	SW1	SW2
20	70	55	46,5	74	32	100	90	38	10	30	48	4	22	12	15	77	71	17	8	48+2	40	8,5	10	24	M6	M8	9	15	9	6,5	11	6,8	13	13
25	70	55	46,5	74	32	100	90	38	10	30	48	6	22	12	15	77	76	17	8	48+2	40	8,5	10	24	M6	M8	9	15	9	6,5	11	6,8	13	17

Guides Mod. 45NHT for cylinders Series 24, 25



Suitable for cylinders Series 24 and 25 DIN/ISO 6432, \varnothing 20 and 25. These guides do not need lubrication.

For applicable loads see graph 3.

Supplied with:
1x fixing nut.

Draw note:
+ = add the stroke

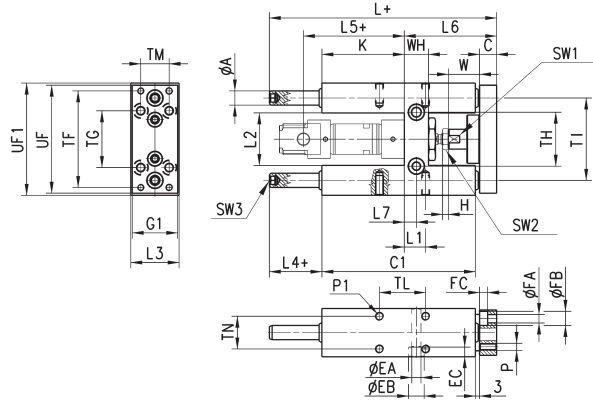

DIMENSIONS																																					
\varnothing	TF	TG	TH	TI	TL	TM	TN	UF	G1	UF1	\varnothing A	WH	C1	H	W	C	K	L	L1	L2	L3	L4	L5	L6	L7	P	P1	T	\varnothing EA	\varnothing EB	EC	\varnothing FA	\varnothing FB	FC	SW1	SW2	SW3
20	68	40	38	58	32,5	20	23	76	32	79	10	17	108	4	22	12	58	160	15	37	34	37	71	65	8,5	M5	M6	14	6,5	11	6,8	5,5	10	5,7	13	13	6
25	68	40	38	58	32,5	20	23	76	32	79	10	17	108	6	17	12	58	160	15	37	34	37	76	65	8,5	M5	M6	14	6,5	11	6,8	5,5	10	5,7	13	17	6

Guides Mod. 45NHB for cylinders Series 24, 25



Suitable for cylinders Series 24 and 25 DIN/ISO 6432, \varnothing 20 and 25. To lubricate these guides, use the special lubricator. For applicable loads see graph No 2.

Supplied with:
1x fixing nut.

Draw note:
+ = add the stroke

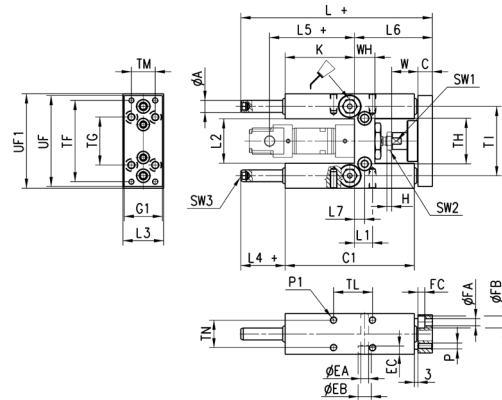

DIMENSIONS																																					
\varnothing	TF	TG	TH	TI	TL	TM	TN	UF	G1	UF1	\varnothing A	WH	C1	H	W	C	K	L	L1	L2	L3	L4	L5	L6	L7	P	P1	T	\varnothing EA	\varnothing EB	EC	\varnothing FA	\varnothing FB	FC	SW1	SW2	SW3
20	68	40	38	58	32,5	20	23	76	32	79	10	17	108	4	22	12	58	160	15	37	34	37	71	65	8,5	M5	M6	14	6,5	11	6,8	5,5	10	5,7	13	13	6
25	68	40	38	58	32,5	20	23	76	32	79	10	17	108	6	17	12	58	160	15	37	34	37	76	65	8,5	M5	M6	14	6,5	11	6,8	5,5	10	5,7	13	17	6