

INSTALLATION INSTRUCTIONS: MCD USB MODULE

1. Introduction

The USB Module can be used in conjunction with WinMaster to manage Danfoss soft starters.

These instructions detail the installation, set-up and configuration of the USB Module. For details on using WinMaster, refer to the WinMaster help file.

2. Installation



CAUTION

Remove mains and control voltage from the soft starter before attaching or removing accessories. Failure to do so may damage the equipment.

MCD 200

Plug the module onto the side of the soft starter.

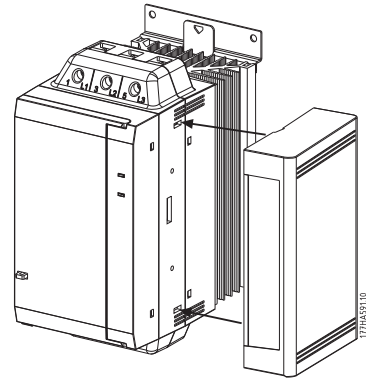

MCD 500:

To plug the module onto the side of the soft starter, line the interface up with the comms port slot.

Press the top retaining clip of the module into the soft starter chassis first, then press in the bottom retaining clip.

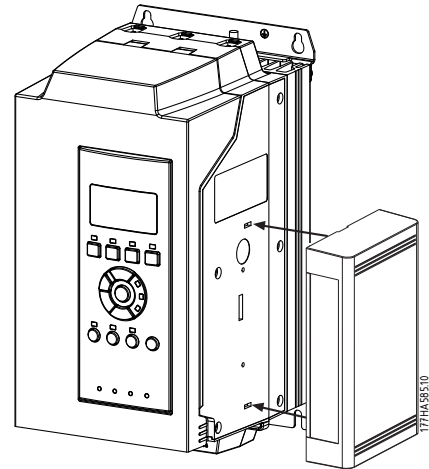

Remove the module using the following procedure:

1. Remove control power and mains supply from the soft starter.
2. Take the module off-line.
3. Disconnect the USB cable from the module.
4. Push a small flat-bladed screwdriver into the slots at the top and bottom of the module and depress the retaining clips.
5. Pull the module away from the soft starter.

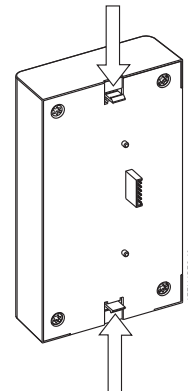

3. Connection

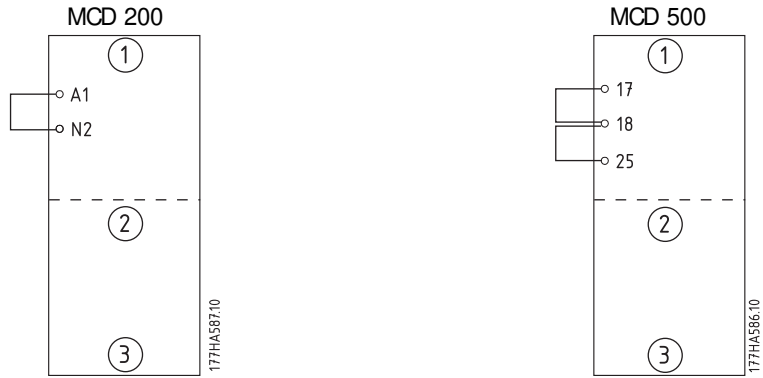

①	MCD 200	①	MCD 500 (Remote mode)
②	USB Module		17, 18: Stop input
③	USB port		25, 18: Reset input
		②	USB Module
		③	USB port

For the USB Module to accept serial commands, a link must be fitted across terminals A1-N2 on MCD 200 starters.

Input links are required across terminals 17 and 25 to 18 if the MCD 500 soft starter is being operated in Remote mode. In Local mode, links are not required.



N.B.!
 MCD 500 parameter 3-2 selects whether the soft starter will accept Start and Stop commands from the Serial Network Master while in Remote Mode. See the soft starter user manual for parameter details.

4. Configuration

To bring the USB Module on-line:

1. Remove control power and mains supply from the soft starter.
2. Attach the module to the soft starter as illustrated.
3. Connect the module to the PC via a USB cable. The PC should detect the module and the Hardware Update Wizard will open.
4. Install the supplied USB UART driver to operate the module as follows.

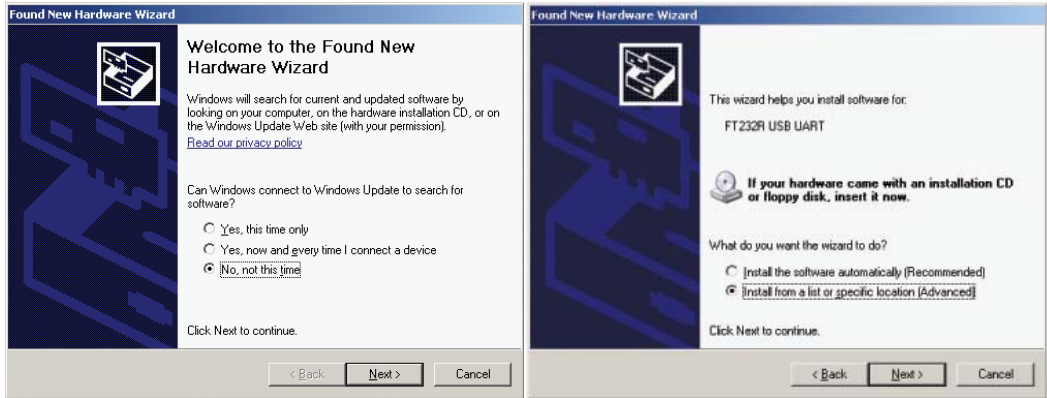

The driver can be found in the USB Comms Drivers folder on the supplied CD. Click on the Browse button then navigate to the drivers folder and select the appropriate folder for your operating system.

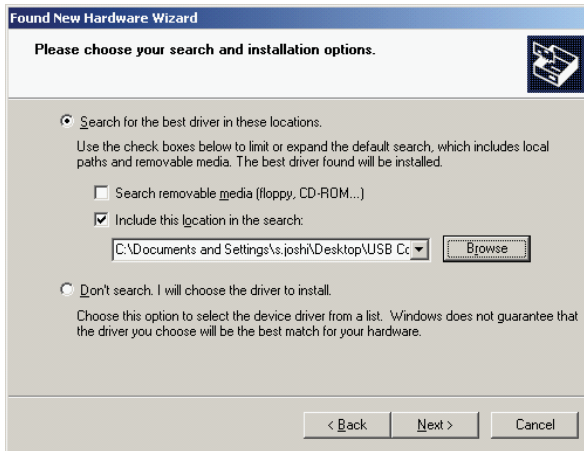

Click on Ok, then Next. The software will install. If you see a prompt, click Continue Anyway. Once installation is complete, click Finish.

5. The PC will prompt you to install serial port driver software. Repeat the procedure in Step 4. You may need to restart your PC once the driver software is installed.

6. Identify the USB Serial Port assignment by checking Control panel > System > Hardware > Device Manager> Ports (COM & LPT).

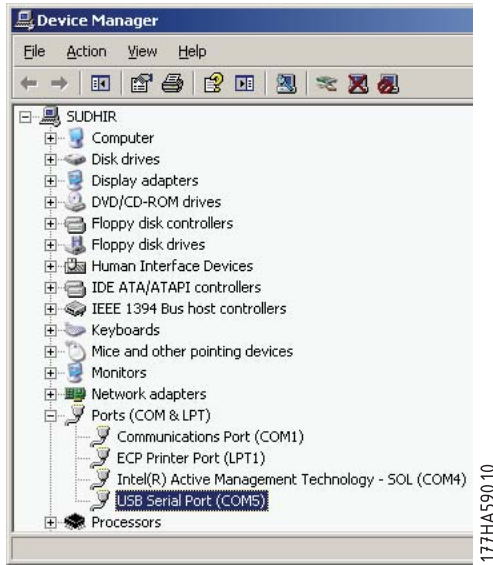

N.B.!:

If the USB port is not shown, disconnect then reconnect the cable. If the problem persists, restart your PC.

7. Open WinMaster and change the Network Settings to:

Protocol: AP Binary or AP ASCII
 Baud rate: 9600
 Serial Port: Use the serial port number identified above

8. Apply control voltage to the soft starter. Bring WinMaster on-line, then Search for Network Starters.



N.B.!:

The starter may trip on Starter Comms while the Master is off-line. Reset the soft starter and place the Master on-line.



N.B.!:

The drivers will configure the USB port that the module is connected to. You must use the same physical USB port every time you connect the module to the PC.

5. Specifications

Order code	175G9009
Enclosure	
Dimensions	35 mm (W) x 157 mm (H) x 90 mm (D)
Weight	250 g
Protection	IP20
Mounting	
Spring-action plastic mounting clips (x 2)	
Connections	
Soft starter	6-way pin assembly
Network	USB-B
Maximum cable length	3 metres (not supplied)
Settings	
Protocol	
MCD 200	AP ASCII
MCD 500	Binary
Address	20
Data rate (bps)	9600

6. Troubleshooting

Symptom	Cause and solution
“Unknown Device has been detected” message when interface is first plugged in	The USB cable may be too long. Use a standard USB cable less than 3 metres long.
WinMaster goes offline and soft starter trips on Starter Comms	The USB cable has been unplugged. Ensure the cable is plugged in at both ends, then bring WinMaster back on-line.
WinMaster locks up when on-line. Log view indicates comms failure and a change to offline mode	Severe external electrical disturbance or equipment failure. Reconnect the USB cable, the close and restart WinMaster. Bring WinMaster on-line. If the problem persists, contact your local supplier.