



BDSI

INLINE BACK DRAUGHT SHUTTER

AIR MANAGEMENT SYSTEMS

PRODUCT PROPERTIES

The Inline backdraught shutter type **BDSI** is used to preventing the reverse of air-flow in circular duct systems.

CONSTRUCTION

The casing of the shutter is made of galvanized steel sheet. The blades are made of aluminium, shaft and spring are made of stainless steel. The inner rubber seal is used for better tightness and for noise reduction. The outer foam sealing strip provides good tightening and fixing of the BDSI inside the duct. The nominal dimensions correspond with the DIN 24145.

Production range and main dimensions see the table.

INSTALLATION

The BDSI has to be installed in horizontal position. The shaft axis must be positioned vertically. The BDSI must be inserted fully into the duct.

OPERATION CONDITIONS

The shutter is destined for operation in a standard environment with ambient temperature up to 60°C, for transportation of clean air free of coarse dust, grease, chemical vapours and other impurities.

The BDSI is sold by the piece.

PRESSURE LOSS

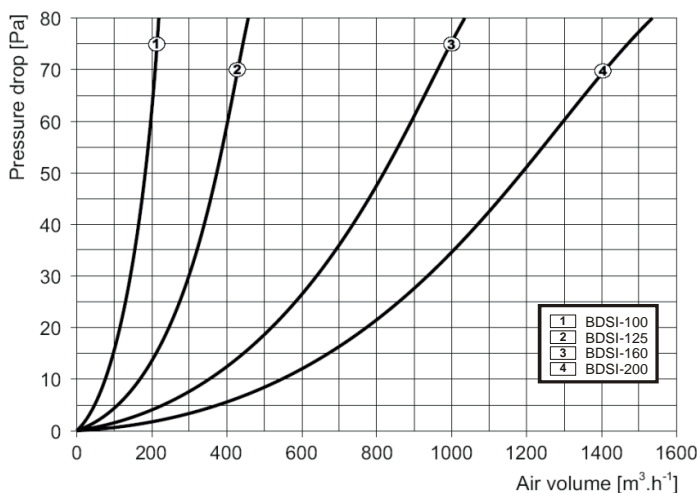

DIMENSIONS (IN MILLIMETRES)

Type	ØD (mm)	L1 (mm)	Average weight
BDSI100	100 +0/-0.5	8	0.15
BDSI125	125 +0/-0.5	17	0.20
BDSI150	150 +0/-0.5	32	0.30
BDSI160	160 +0/-0.5	37	0.40
BDSI200	200 +0/-0.5	56	0.70

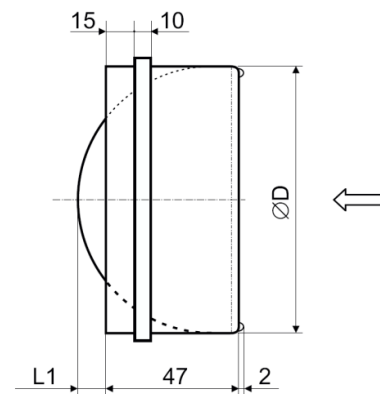

LIABILITY:

The information contained in this brochure was current on the publication date. DEC INTERNATIONAL reserves the right to make changes in details at any time without prior notice. In order to avoid misunderstandings, any interested party is advised to contact DEC INTERNATIONAL checking for any changes in materials and/or information after this brochure was published.

PLEASE NOTICE:

The consultant is responsible for the actual installation and mounting of the product. The mentioned values with respect to temperatures are not appropriate to be used to determine the physical properties. These properties are also dependent on humidity and the temperature of the air inside and outside of the H.V.A.C. system.

TRADEMARKS:

DEC International and the DEC logo are trademarks, or registered trademarks of Dutch Environment Corporation BV in the Netherlands and/or other countries.

