

DH-CS4218-16ET-240

18-Port Cloud Managed Desktop Switch with 16-Port PoE



PoE2.0

Series Overview

Highly intuitive, the Cloud Managed Switch can manage local networks. With the DoLynk Care platform, it can also perform cloud management. The switch performs operation and maintenance using topology visualization on front-end, transmission and back-end storage devices that are in the security system and IT system. With its full metal design, the switch has great heat dissipation and can operate in temperatures ranging -10°C to 55°C(+14°F to +131°F). It offers EMC and has protection against overvoltage, overcurrent, static electricity, lightning strikes, pulses and other types of interference. For the PoE series Smart Managed Switch, power is supplied up to 250 meters away. The orange port supplies up to 60 W and the red port provides up to 90 W. The switch can be used in small and medium-sized businesses such as supermarkets, offices, restaurants, cafés and hotels.

Functions

Cloud Management

Devices can be managed through the DoLynk Care app and performs real-time monitoring of the network. The app also displays the status of devices, triggers alarms for errors in real time and sends notifications.

Network Topology Management

Supports the LLDP protocol and is able to generate and display the network topology, so that you can quickly identify issues, and perform operation and maintenance remotely on devices that are in the topology.

- 16 × RJ45 10/100 Mbps PoE Ports, 2 Gigabit combo ports.
- 240 W total PoE budget, 802.3af/at on all PoE port, additional 802.3bt on red port.
- Wide operating temperature ranging from -10 °C to 55 °C.
- Supports VLAN and loop protection.
- WEB-managed and centralized cloud management through the DoLynk app and performs real-time monitoring of the network.
- Easy config to auto detect and set up network and security systems.



BT 90W (Red Port)

The red ports support IEEE802.3af, IEEE802.3at, IEEE802.3bt and Hi-PoE standards, with a maximum output power consumption of 90W per port. Suitable for powering high-power devices.

Long Distance PoE

The transmission distance of a PoE port can be up to 250 m, meeting the requirement of wired transmission (bandwidth reduced to 10 Mbps).

PoE Watchdog

Adopts the innovative PoE Watchdog. It enables the switch to automatically detect port status and restart the failed ports to recover connection in case of IPC connection exception. This enables intelligent operation and maintenance management in its true sense and effectively reduces manual maintenance costs.

Loop Protection

When a loop is detected, the loop alarm will be triggered and the elimination mechanism will activate to prevent broadcast storms from occurring.

Scene

Suitable for scenes such as houses, factories and offices.

Technical Specification

Basic

Layer	Layer 2
Switching Capacity	7.2 Gbps
Packet Forwarding Rate	5.36 Mpps
Description of Function Slots	Port 1-16: 16 × RJ45 10/100 Mbps (PoE); Port 17-18: 2 × RJ45 10/100/1000 Mbps (combo); Port 17-18: 2 × SFP 1000 Mbps (combo)
Operating Temperature	-10 °C to +55 °C (+14 °F to +131 °F)
Operating Humidity	5%–95% (RH), non-condensing
Storage Temperature	-40 °C to +70 °C (-40 °F to +158 °F)
Storage Humidity	5%–95% (RH), non-condensing
Power Supply	Built-in power supply: 100–240 VAC, 47–63 Hz, max 4 A
Power Consumption	Idling: ≤6 W Full load: 265 W
Statics Protection	Air discharge: 8 kV; Contact discharge: 6 kV
Lightning Protection	Common mode: 4 kV Differential mode: 2 kV
Net Weight	2.35 kg (5.17 lb)
Gross Weight	3.0 kg (6.6 lb)
Product Dimensions	440 mm × 220 mm × 44 mm (17.32" × 8.66" × 1.73") (L × W × H)
Packaging Dimensions	540 mm × 342 mm × 90 mm (21.26" × 13.46" × 3.54") (L × W × H)
Casing Material	Sheet metal
Installation	Desktop mount; rack mount

PoE

PoE	Yes
PoE Power	Port 1-2 ≤ 90 W, Port 3-16 ≤ 30 W, total ≤ 240 W
PoE Protocol	IEEE802.3af; IEEE802.3at; Hi-PoE; IEEE802.3bt
PoE Power Consumption Management	PoE power consumption management; PoE power on/off; turns off PoE if overload is detected
PoE Pin Assignment	1,2,4,5 (V+), 3,6,7,8 (V-)
Long Distance PoE Transmission	Yes

Hardware

Reset Button	1
--------------	---

Performance

MTBF	87.10 years
Packet Buffer Size	4 Mbit
Jumbo Frame	9216 Byte
MAC Table Size	8K
Communication Standard	IEEE 802.3 IEEE 802.3u IEEE 802.3x

Communication Standard	IEEE 802.3ab IEEE 802.3az IEEE 802.3z
VLAN Number	32

Feature

VLAN Function	IEEE 802.1Q VLAN
Port Feature	IEEE 802.3x Flow Control Unknown Unicast Suppression Multicast Storm Control Broadcast Storm Control MAC+Port Binding Loop Prevention
Mirror	N:1 Mirroring Local Port Mirroring
Reliability	LLDP
DHCP Function	DHCP Client
Security	Port Isolation
Equipment Management	Web Management Cloud Management Logs Fault Alarm

General

Packing List	Quick Start Guide × 1 Legal and Regulatory Information × 1 Power cord × 1 Rack-mount kit × 1
--------------	---

Transmission Performance

Switch power supply voltage 54V.
CAT6. Max. DC resistance < 8 Ω/100 m

Cable(m)	Load Capacity(W)	Bandwidth(Mbps)
IEEE802.3bt 90W		
100	71.3	100
150	62	10
200	51	10
250	40	10

Hi-PoE 60W

100	46	100
150	42	10
200	37	10
250	32	10

IEEE802.3at 30W

100	25.5	100
150	25.5	10
200	25.5	10
250	24	10

Cloud Managed Switch | DH-CS4218-16ET-240

Note: Data from this table was collected by Dahua test lab and is for reference only. The actual transmission distance may vary due to power consumption of connected devices or the cable type and status.

Ordering Information

Type	Model	Description
PoE Switch	DH-CS4218-16ET-240	18-Port Cloud Managed Desktop Switch with 16-Port PoE
Accessories (Optional)	GSFP-1310T-20-SMF	SFP Optical Module
	GSFP-1310R-20-SMF	SFP Optical Module
	GSFP-850-MMF	SFP Optical Module
	GSFP-1310-20-SMF	SFP Optical Module

Accessories

Optional:



GSFP-1310-20-SMF
SFP Optical Module



GSFP-1310R-20-SMF
SFP Optical Module



GSFP-1310T-20-SMF
SFP Optical Module



GSFP-850-MMF
SFP Optical Module

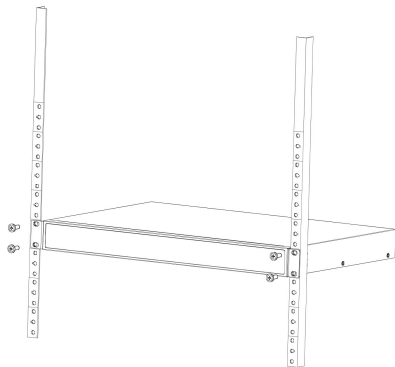

Dimensions (mm[inch])

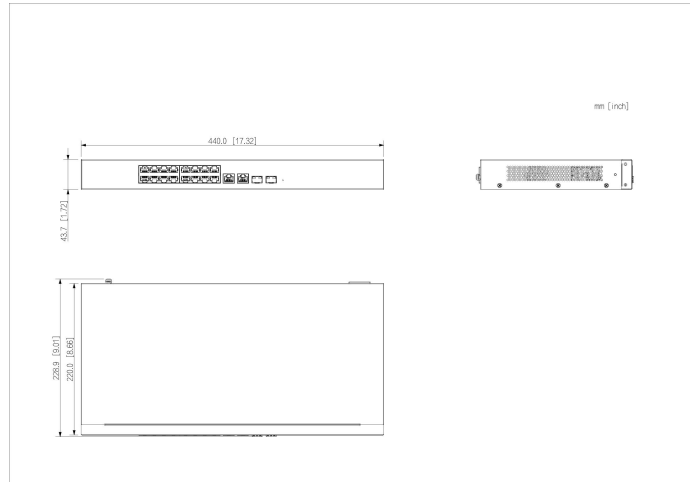

Panels

