

Produktdatablad

Specifikationer



Harmony dobbelt trykknaphoved i metal for LED med et sort "I" på en hvid flade og et hvidt "O" på en sort flade

El-nr.:
7517801782

ZB4BW7A1721

EAN-nr: 3389119043731

Egenskaber

Produktserie	Harmony XB4
Produkttype	Hoved til dobbelt trykknop med LED
Produktet passer med	Integreret LED
Enhedsforkortelse	ZB4
Materiale og farve på frontring	Forkromet metal
Hovedtype	Standard
Montagediameter	22 mm
Mindst mulige salgsantal	1
Form på hoved	Rektangulær
Betjeningsprofil	fjeder-retur
Betjeningsprofil	2 plan trykknapper - 1 signallampe i midt
Betjeningsbeskrivelse	Hvid "I" - sort "O"

Produktinformationer

Bredde	30 mm
Højde	50 mm
Dybde	30 mm
Vægt	0,056 kg
Modstandsdygtighed overfor højtryksrensning	7000000 Pa ved 55 °C, distance : 0.1 m
Farve på mærkning	Sort mærkning ved hvid trykflade Hvid mærkning ved grøn, rød eller sort trykflade
Betjeningsprofil	Sort Plan, O (Hvid) Hvid Plan, I (Sort)
Mekanisk holdbarhed	1000000 kredsløb
Kode for elektrisk sammensætning	M1 til <6 kontakter benytter enkelt blokke i Montering forfra med integreret LED M2 til <6 kontakter benytter enkelt og dobbelt blokke i Montering forfra med integreret LED M6 til <2 kontakter benytter enkelt blokke i Montering forfra med integreret LED og transformere M10 til <2 kontakter benytter enkelt blokke i Montering forfra med integreret LED
Konstruktion	Som hoved og krop

Miljø

Beskyttelsesbehandling	TH
------------------------	----

Ansvarsfraskrivelse: Denne dokumentation er ikke tænkt som en erstatning for og kan ikke anvendes til at afgøre egnetheden eller pålideligheden for disse produkter til bestemte anvendelsesformål.

Omgivelsestemperatur ved opbevaring	-40...70 °C
Omgivelsestemperatur under drift	-40...70 °C
Beskyttelsesklasse	Klasse I i henhold til IEC 61140
IP kapslingsklasse	IP66 i henhold til IEC 60529 IP67 i henhold til IEC 60529 IP69 IP69K
NEMA kapslingsklasse	NEMA 13 NEMA 4X
IP kapslingsklasse	IK06 conforming to IEC 50102
Standarder	IEC 60947-5-4 UL 508 JIS C8201-5-1 IEC 60947-5-1 IEC 60947-1 IEC 60947-5-5 CSA C22.2 No 14 JIS C8201-1
Produktcertificeringer	CSA LROS (Lloyds register of shipping) BV UL listet DNV
Vibrationsmodstand	5 gn (f= 2...500 Hz) conforming to IEC 60068-2-6
Modstandsdygtighed overfor stød	30 gn (varighed = 18 milisekund) til Halv sinusbølge acceleration i henhold til IEC 60068-2-27 50 gn (varighed = 11 milisekund) til Halv sinusbølge acceleration i henhold til IEC 60068-2-27

Forpakkingsinformation

Enhedstype af pakke 1	PCE
Antal enheder i pakke 1	1
Pakke 1 Højde	5,500 cm
Pakke 1 Længde	3,300 cm
Package 1 Length	5,300 cm
Pakke 1 Vægt	56,800 g
Enhedstype af pakke 2	BB1
Antal enheder i pakke 2	5
Pakke 2 Højde	5,500 cm
Pakke 2 Bredde	3,300 cm
Pakke 2 Længde	26,500 cm
Pakke 2 Vægt	284,000 g
Enhedstype af pakke 3	S03
Antal enheder i pakke 3	200
Pakke 3 Højde	30,000 cm
Pakke 3 Bredde	30,000 cm
Pakke 3 Længde	40,000 cm
Pakke 3 Vægt	11,874 kg

Logistik informationer

Oprindelsesland FR

Garanti

Garanti 18 months

Environmental Data

Schneider Electric's mål er at opnå Net Zero-status i 2050 gennem partnerskaber med forsyningskæden, materialer med lavere påvirkning og cirkularitet via vores igangværende kampagne "Use Better, Use Longer, Use Again" for at forlænge produkternes levetid og genbrugelighed.

[Forklaring af Environmental Data >](#)

[Sådan vurderer vi produktets bæredygtighed >](#)

Miljøfodaftryk

CO2-belastning (kg CO2 eq.) 1

Miljøoplysning [Miljøprofil for produkt](#)

Use Better

Materialer og emballage

Pakke med genbrugspap Yes

Emballage uden plast Yes

[EU RoHS-direktivet](#) Proaktiv overensstemmelse (produkt ikke omfattet af EU RoHS)

Reach-forordning [REACH-erklæring](#)

Use Again

Ompakning og genfremstilling

Cirkularitetsprofil [Oplysninger om udtjent udstyr](#)

Returnering No

Dimensions Drawings

Dimensions

Without Boot

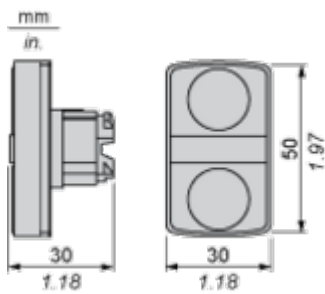

With Boot ZBA708

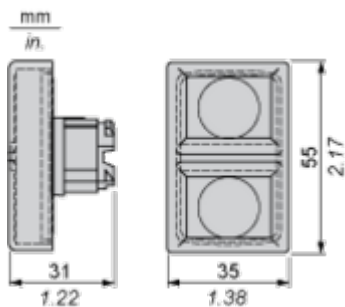

Mounting and Clearance

Panel Cut-out for Pushbuttons, Switches and Pilot Lights (Finished Holes, Ready for Installation)

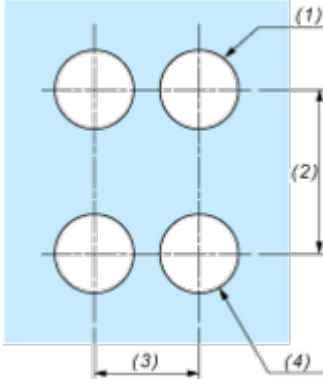
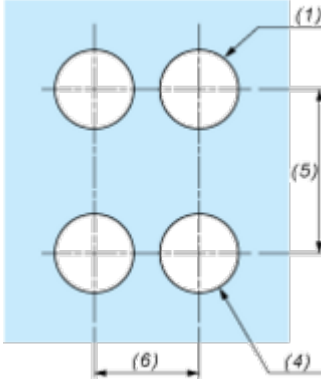
Connection by Screw Clamp Terminals or Plug-in Connectors or on Printed Circuit Board	Connection by Faston Connectors
	
<p>(1) Diameter on finished panel or support</p> <p>(2) 40 mm min. / 1.57 in. min.</p> <p>(3) 30 mm min. / 1.18 in. min.</p> <p>(4) $\varnothing 22.5 \text{ mm} / 0.89 \text{ in. recommended } (\varnothing 22.3 \text{ mm }_0^{+0.4} / 0.88 \text{ in. }_0^{+0.016})$</p> <p>(5) 45 mm min. / 1.78 in. min.</p> <p>(6) 32 mm min. / 1.26 in. min.</p>	



A: 1.18 in. min.
 B: 1.57 in. min.

General Tolerances of the Panel and Printed Circuit Board

The cumulative tolerance must not exceed 0.3 mm / 0.012 in: T1 + T2 = 0.3 mm max.

Installation Precautions

- Minimum thickness of circuit board: 1.6 mm / 0.06 in.
- Cut-out diameter: 22.4 mm ± 0.1 / 0.88 in. ± 0.004
- Orientation of body/fixing collar ZB4 BZ009: ± 2° 30' (excluding cut-outs marked a and b).
- Tightening torque of screws ZBZ 006: 0.6 N.m (5.3 lbf.in) max.
- Allow for one ZB4 BZ079 fixing collar/pillar and its fixing screws:
 - every 90 mm / 3.54 in. horizontally (X), and 120 mm / 4.72 in. vertically (Y).
 - with each selector switch head (ZB4 BD*, ZB4 BJ*, ZB4 BG*).

The fixing centers marked a and b are diagonally opposed and must align with those marked 4 and 5.



(1) Panel

(2) Printed circuit board

Mounting of Adapter (Socket) ZBZ 01•

- 1 2 elongated holes for ZBZ 006 screw access
- 2 1 hole Ø 2.4 mm ± 0.05 / 0.09 in. ± 0.002 for centring adapter ZBZ 01•
- 3 8 × Ø 1.2 mm / 0.05 in. holes
- 4 1 hole Ø 2.9 mm ± 0.05 / 0.11 in. ± 0.002, for aligning the printed circuit board (with cut-out marked a)
- 5 1 elongated hole for aligning the printed circuit board (with cut-out marked b)
- 6 4 holes Ø 2.4 mm / 0.09 in. for clipping in adapter ZBZ 01•

Dimensions An + 18.1 relate to the Ø 2.4 mm ± 0.05 / 0.09 in. ± 0.002 holes for centring adapter ZBZ 01•.

Technical Description

Electrical Composition Corresponding to Codes M1 and M7

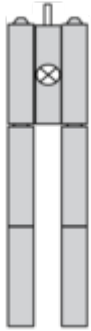

Electrical Composition Corresponding to Codes M2 and M8

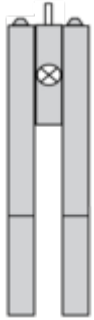

Electrical Composition Corresponding to Codes M6 and P2



Electrical Composition Corresponding to Codes M5, M10, MF1, MR1 and MF2



Legend

Single contact



Double contact



Light block



Possible location



Technical Illustration

Dimensions

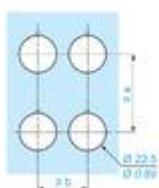
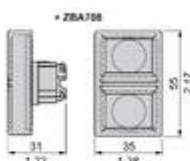
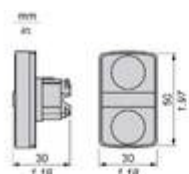

		a (mm)	a (in.)	b (mm)	b (in.)
		40	1.57	30	1.18
ZBE*****	ZBV*****				
		45	1.77	32	1.26
ZBE*****3	ZBV*****3				
		40	1.57	30	1.18
ZBE*****1	ZBV*****1				
		50	1.97	30	1.18
ZBE*****5	ZBV*****5				
		40	1.57	30	1.18
ZBE*****9	ZBV*****9				
ZBE*****	ZBRv1	40	1.57	30	1.18

Offer Marketing Illustration

Product benefits / Features

Features
Harmony XB4/XB5 Illuminated functions

NEW universal LED Block for all colors

Simple stock management

Improved installation time and easy selection

Improved color intensity and brightness

The image features a green background with the title 'Features' and subtitle 'Harmony XB4/XB5 Illuminated functions'. It displays four key benefits, each with a circular icon and a corresponding photograph of the product. The benefits are: 1. 'NEW universal LED Block for all colors' with a square icon containing a smaller square. 2. 'Simple stock management' with an icon of a person holding a document. 3. 'Improved installation time and easy selection' with a circular arrow icon. 4. 'Improved color intensity and brightness' with a sun icon. The product images show various colored buttons (green, red, yellow) and their internal LED components.

Offer Marketing Illustration

Product benefits / Features

Technical Benefits

Harmony XB4

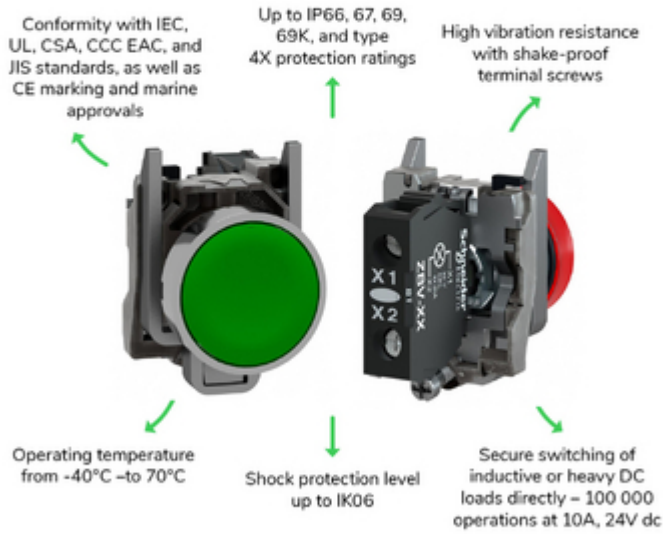

Offer Marketing Illustration

Product benefits / Features

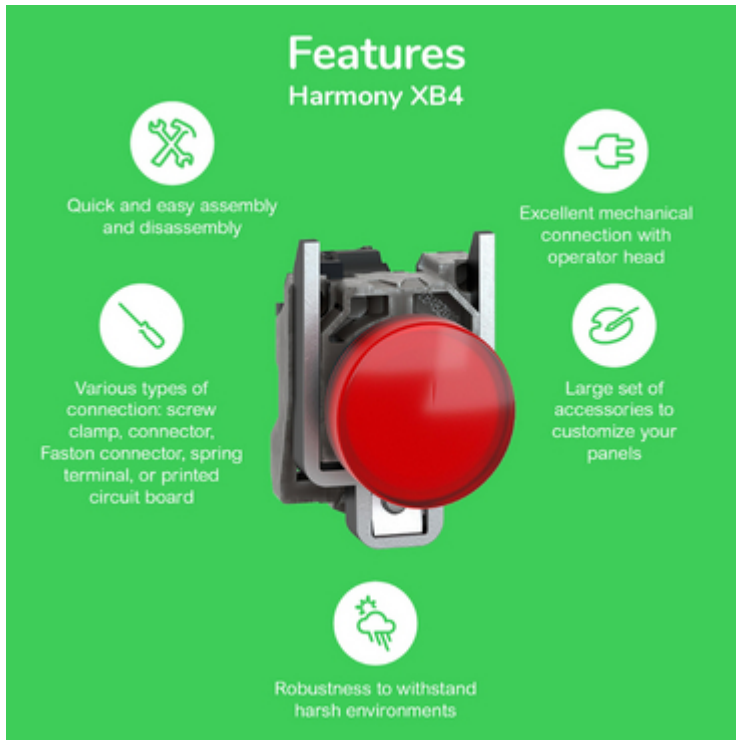

The infographic features a central image of a red Schneider XB4 circuit breaker. Surrounding it are five circular icons, each with a corresponding text block describing a feature. The background is a solid green color.

Features Harmony XB4

- Quick and easy assembly and disassembly** (Icon: crossed wrench and screwdriver)
- Excellent mechanical connection with operator head** (Icon: hand holding a plug)
- Large set of accessories to customize your panels** (Icon: plug with a slash through it)
- Robustness to withstand harsh environments** (Icon: lightning bolt and rain cloud)
- Various types of connection: screw clamp, connector, Faston connector, spring terminal, or printed circuit board** (Icon: screwdriver)

Image of product / Alternate images

Alternative



