

Produktdatablad

Specifikationer



Harmony XVU Ø60 mm lystårn, montagefod i mørkegrå med 100 mm rør og fjederklemmer

El-nr.:

7586048932

XVUZ02

EAN-nr: 3606480556012

Egenskaber

Produktserie	Harmony XVU
Produkttype	Modular tower lys
Tilbehør/reservedele type	Fastgørelsesplade
Tilbehør/reservedele kategori	Tilbehør for montage og fastgørelse
type nr.	XVU
Montagediameter	60 mm

Produktinformationer

Pole heigth	100 mm
Montagetilbehør	Plade med stav
Kompatibilitet	Top: AC krop Top: DC krop Top: drejemontage support
materiale	PBT (polybutylenterephthalat) V-0 brandhæmmende i henhold til UL 94 ABS (acrylonitril butadien-styren) PC (polycarbonat) Aluminium
farve på hus	Sort
Tilslutningsklemmer	Push-in
Nominel forsyningsspænding [Us]	24 V AC/DC 110...240 V AC
længde	117 mm
Vægt	0,132 kg

Miljø

Omgivelsestemperatur ved opbevaring	-40...70 °C
Omgivelsestemperatur under drift	-25...50 °C
IP kapslingsklasse	IP65
Produktcertificeringer	CSA UL CE

Forpakkingsinformation

Enhedstype af pakke 1	PCE
Antal enheder i pakke 1	1
Pakke 1 Højde	9,1 cm

Pakke 1 Længde	26,8 cm
Package 1 Length	9,0 cm
Pakke 1 Vægt	285,0 g
Enhedstype af pakke 2	S03
Antal enheder i pakke 2	12
Pakke 2 Højde	30,0 cm
Pakke 2 Bredde	30,0 cm
Pakke 2 Længde	40,0 cm
Pakke 2 Vægt	4,481 kg
Enhedstype af pakke 3	PAL
Antal enheder i pakke 3	96
Pakke 3 Højde	60,0 cm
Pakke 3 Bredde	80,0 cm
Pakke 3 Længde	70,0 cm
Pakke 3 Vægt	35,36 kg

Logistik informationer

Oprindelsesland	ID
-----------------	----

Environmental Data

Schneider Electric's mål er at opnå Net Zero-status i 2050 gennem partnerskaber med forsyningskæden, materialer med lavere påvirkning og cirkularitet via vores igangværende kampagne "Use Better, Use Longer, Use Again" for at forlænge produkternes levetid og genbrugelighed.

[Forklaring af Environmental Data](#) >

[Sådan vurderer vi produktets bæredygtighed](#) >

Miljøaftryk

CO2-belastning (kg CO2 eq.) 1

Miljøoplysning [Miljøprofil for produkt](#)

Use Better

Materialer og emballage

Pakke med genbrugspap Yes

Emballage uden plast Yes

[EU RoHS-direktivet](#) Proaktiv overensstemmelse (produkt ikke omfattet af EU RoHS)

SCIP-nummer 01c0c8da-c8d4-4c46-ae0e-6b6f43e7bc02

Reach-forordning [REACH-erklæring](#)

Use Again

Ompakning og genfremstilling

Cirkularitetsprofil [Oplysninger om udtjent udstyr](#)

Returnering No

Dimensions Drawings

Fixing Unit - Plate with Pole

Dimensions

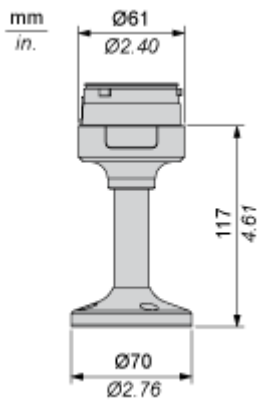

Mounting and Clearance

Modular Tower Lights Mounting

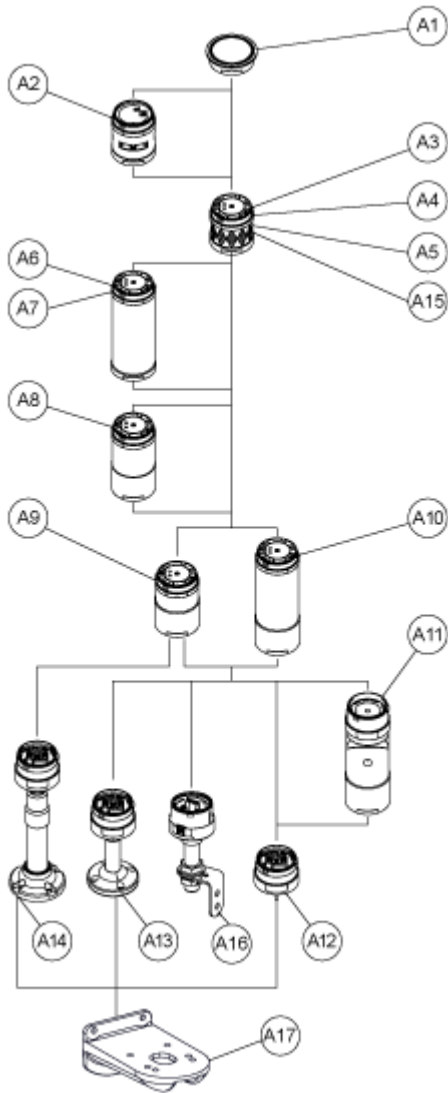

Drawing	Part number	Part name
A1	-	Top cover
	-	Top cover (Silver)
A2	XVUC9S	Buzzer unit
	XVUC9SQ	Buzzer unit (Silver)
A3	XVUC23	Green LED unit
	XVUC24	Red LED unit
	XVUC25	Orange LED unit
	XVUC26	Blue LED unit

Drawing	Part number	Part name
	XVUC27	White LED unit
	XVUC28	Yellow LED unit
A4	XVUC29	Multi-LED unit
A5	XVUC29P	Multi-LED unit, Pulse signal
A6	XVUC9V	Sound unit
A7	XVUC9VP	Sound unit, Pulse signal
A8	XVUC020	Extender
	XVUC020Q	Extender (Silver)
A9	XVUC21B	DC body
	XVUC21BQ	DC body (Silver)
A10	XVUC21M	AC body NPN
	XVUC21MP	AC body PNP
	XVUC21MQP	AC body PNP (Silver)
A11	XVUZ06	Flexible option
A12	XVUZ01	Fixing Unit - Direct mounting (3 pins)
	XVUZ01Q	Fixing Unit - Direct mounting (Silver,3 pins)
	XVUZ03	Fixing Unit - Direct mounting (2 pins)
	XVUZ04	Fixing Unit - Direct mounting (4 pins)
A13	XVUZ02	Fixing Unit - Plate with Pole (100 mm)
	XVUZ02Q	Fixing Unit - Plate with Pole (100 mm, Silver)
	XVUZ400	Fixing Unit - Plate with Pole (400 mm)
	XVUZ800	Fixing Unit - Plate with Pole (800 mm)
A14	XVUZ05	Fixing Unit - Plate with adjustment pole (100-385 mm)
A15	XVUC43	Green LED unit, Flash
	XVUC44	Red LED unit, Flash
	XVUC45	Orange LED unit, Flash
	XVUC46	Blue LED unit, Flash

Drawing	Part number	Part name
	XVUC47	White LED unit, Flash
	XVUC48	Yellow LED unit, Flash
A16	XVUZ100T	Fixing Unit - Metal bracket with pole (100 mm)
	XVUZ250T	Fixing Unit - Metal bracket with pole(250 mm)
	XVUZ400T	Fixing Unit - Metal bracket with pole (400 mm)
A17	XVUZ12	Fixing plate for use on vertical support - black

Modular Tower Lights Mounting

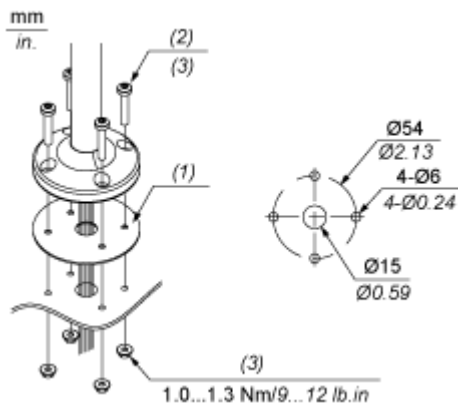

- (1) Gasket
- (2) Screw x 4 (unattached)
- (3) M5 x (thickness+10 mm /0.39 in.)

Connections and Schema

Illuminated Units, Multi-LED and Audible Units Wiring

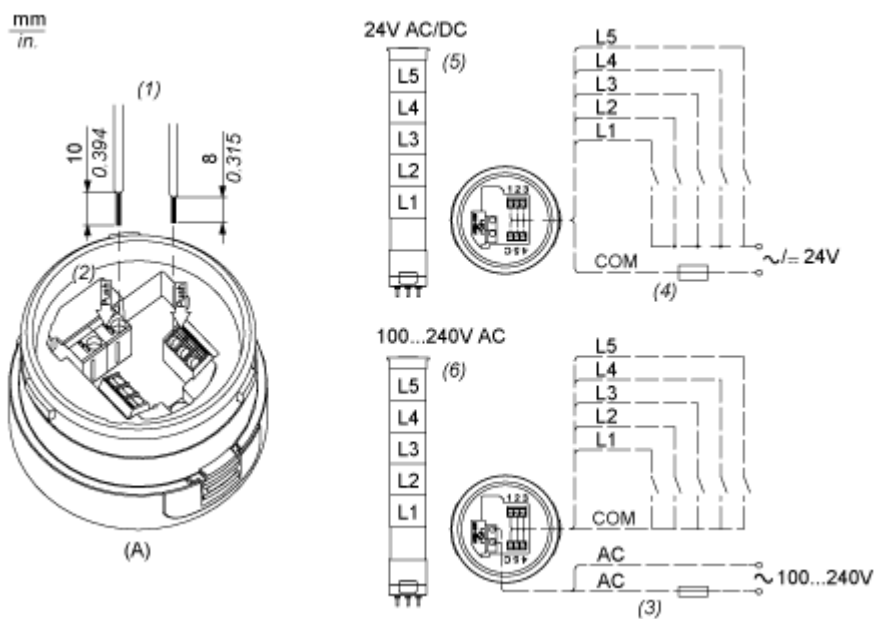

- (A) Fixing Unit
 - (1) Dimensions of Wiring size
 - (2) Push-in Wire Connectors
 - (3) Fuse : 2A ,250V
 - (4) Fuse : 0.5A ,125V
 - (5) Modular Tower Lights 24V AC/DC
 - (6) Modular Tower Lights 100...240V AC
- L1 to L5 : Illuminated LED Units

Technical Illustration

Dimensions

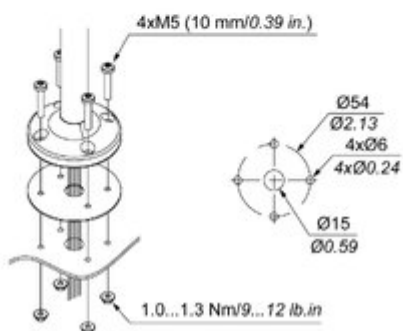
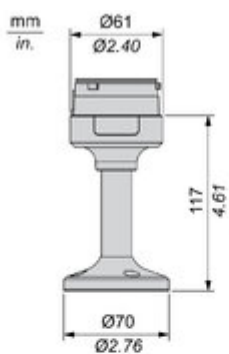

Technical Illustration

Wiring diagram

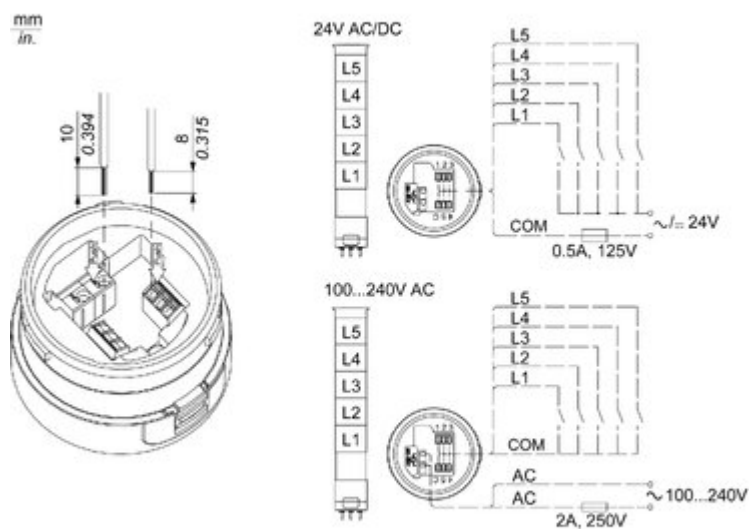

Offer Marketing Illustration

Product benefits / Features

The infographic features a central image of a vertical stack of five light units in various colors (red, orange, green, blue, grey). Surrounding this central image are five circular icons, each with a corresponding text block describing a feature. The background is a solid green color.

Features Harmony XVU

- 6 colors + multi color LED with 4 light patterns: steady, flashing, blinking, and rotating**
- Modular design supporting customization up to 5 light units**
- 4 mounting styles: flexible, wall, pole, or direct mounting**
- Simplified installation, easy maintenance, and direct connection to PLC**
- Programmable sounders that is configurable via the SD card**

Offer Marketing Illustration

Product benefits / Features

Technical Benefits

Harmony XVU

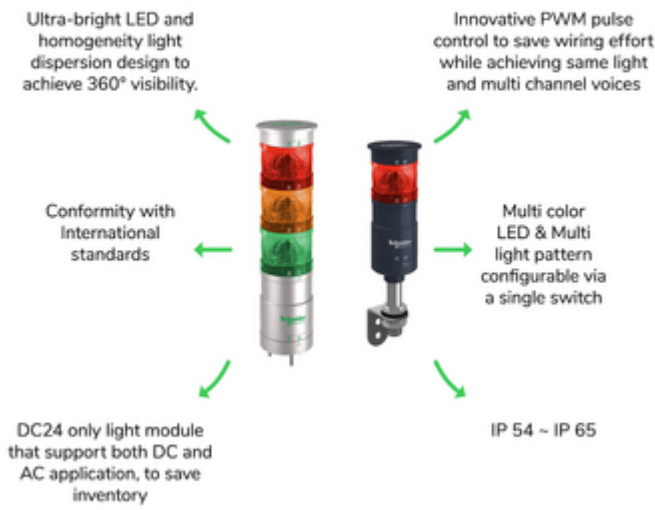

Image of product / Alternate images

Alternative



