

# Produktdatablad

Specifikationer



## Frekvensomformer 0.75kW 200-250V Bogform IP20

El-nr.:

7565724756

ATV320U07M2B

EAN-nr: 3606480966347

## Egenskaber

Produktserie	Altivar Maskine ATV320
Produkttype	Frekvensomformer
Produktspecifik applikation	Komplekse maskiner
Variant	Standard version Standard version
format på drev	Bog
Montageform	Cabinet mount
Kommunikationsportsprotokol	Modbus serial CANopen
option kort	Kommunikations modul, CANopen Kommunikations modul, EtherCAT Kommunikations modul, Profibus DP V1 Kommunikations modul, Profinet Kommunikations modul, Ethernet powerlink Kommunikations modul, EtherNet/IP Kommunikations modul, DeviceNet
[Us] forsyningspænding	200...240 V - 15...10 %
Nominel udgangsstrøm	4,8 A
motoreffekt i kW	0,75 kW til heavy duty
EMC filter	Indbygget Klasse C2 EMC filter
IP beskyttelsesgrad	IP20

## Produktinformationer

digital indgangsnummer	7
digital indgangstype	STO sikkerhedsvridning fra, 24 V DC, impedans: 1.5 kOhm DI1...DI6 logic inputs, 24 V DC (30 V) DI5 programmerbar as pulse input: 0...30 kHz, 24 V DC (30 V)
digital indgangslogik	Positiv logik (source) Negativ logik (sink)
antal digitale udgange	3
digital udgangstype	Åben samler DQ+ 0...1 kHz 30 V DC 100 mA Åben samler DQ- 0...1 kHz 30 V DC 100 mA
Analoge Indgange	3
analog indgangstype	"AI1" voltage: 0...10 V DC, impedans: 30 kOhm, opløsning 10 bits "AI2" bipolar differential spænding: "+/- 10 V" DC, impedans: 30 kOhm, opløsning 10 bits "AI3" strøm: 0...20 mA (or 4-20 mA, x-20 mA, 20-x mA eller andre mønstre ved konfigurerings), impedans: 250 Ohm, opløsning 10 bits
Analoge udgange	1

<b>analog udgangstype</b>	Software-konfigurerbar strøm "AQ1": 0...20 mA impedans 800 Ohm, opløsning 10 bits Software-konfigurerbar spænding "AQ1": 0...10 V DC impedans 470 Ohm, opløsning 10 bits
<b>relæ output type</b>	Konfigurerbar relæ logic "R1A" 1 NO elektrisk holdbarhed 100000 kredsløb Konfigurerbar relæ logic "R1B" 1 NC elektrisk holdbarhed 100000 kredsløb Konfigurerbar relæ logic "R1C" Konfigurerbar relæ logic "R2A" 1 NO elektrisk holdbarhed 100000 kredsløb Konfigurerbar relæ logic "R2C"
<b>maksimum sluttestrøm</b>	Relæ udgang "R1A, R1B, R1C" til modstandsdygtig belastning, cos phi = 1: 3 A ved "250 V" AC Relæ udgang "R1A, R1B, R1C" til modstandsdygtig belastning, cos phi = 1: 3 A ved 30 V DC Relæ udgang "R1A, R1B, R1C, R2A, R2C" til inductiv belastning, cos phi = 0,4 og L/R = 7 millisekund: 2 A ved "250 V" AC Relæ udgang "R1A, R1B, R1C, R2A, R2C" til inductiv belastning, cos phi = 0,4 og L/R = 7 millisekund: 2 A ved 30 V DC Relæ udgang R2A, R2C til modstandsdygtig belastning, cos phi = 1: 5 A ved "250 V" AC Relæ udgang R2A, R2C til modstandsdygtig belastning, cos phi = 1: 5 A ved 30 V DC
<b>minimum sluttestrøm</b>	Relæ udgang "R1A, R1B, R1C, R2A, R2C": 5 mA ved 24 V DC
<b>tilgangsmetode</b>	Slave CANopen
<b>4 quadrant operation possible</b>	Sandt
<b>asynkron motorkontrol</b>	Spændings/frekvens ratio, 5 points Flux vector control uden sensor, standard Spændings/frekvens ratio - energibesparelse, kvadratisk U/f Flux vector control uden sensor - energibesparelse Spændings/frekvens ratio, 2 points
<b>synkronmotorkontrol</b>	Vector kontrol uden sensor
<b>Maximum output frequency</b>	0,599 kHz
<b>accelerations- og nedreguleringsrampe</b>	Linear U S CUS Ramp switching Acceleration/deceleration ramp adaptation Acceleration/deceleration automatic stop with DC injection
<b>motor kompensation</b>	Automatik uanset belastning Justerbar 0...300 % Ikke tilgængelig i spænding/frekvens ratio (2 eller 5 points)
<b>frekvens</b>	"2...16 kHz" Justerbar "4...16 kHz" med reducereing
<b>nominel switching frekvens</b>	4 kHz
<b>bremssning ved stilstand</b>	Med DC indsprøjtning
<b>Brake chopper integrated</b>	Sandt
<b>optagen strøm</b>	10,1 A ved "200 V" (heavy duty) 8,5 A ved 240 V (heavy duty)
<b>Maximum input current</b>	10,1 A
<b>Maximum output voltage</b>	240 V
<b>tilsyneladende effekt</b>	2,0 kVA ved 240 V (heavy duty)
<b>Netværksfrekvens</b>	50...60 Hz
<b>Relative symmetric network frequency tolerance</b>	5 %
<b>prospektiv kortslutningsstrøm I<sub>sc</sub></b>	1 kA
<b>Base load current at high overload</b>	17,0 A
<b>effekttab i W</b>	Ventilator: 46,0 W ved "200 V" 4 kHz

With safety function Safely Limited Speed (SLS)	Sandt
With safety function Safe brake management (SBC/SBT)	Falsk
With safety function Safe Operating Stop (SOS)	Falsk
With safety function Safe Position (SP)	Falsk
With safety function Safe programmable logic	Falsk
With safety function Safe Speed Monitor (SSM)	Falsk
With safety function Safe Stop 1 (SS1)	Sandt
With sft fct Safe Stop 2 (SS2)	Falsk
With safety function Safe torque off (STO)	Sandt
With safety function Safely Limited Position (SLP)	Falsk
With safety function Safe Direction (SDI)	Falsk
beskyttelsestype	Indgangsfase fejl: køre Overspænding mellem output phases og earth: køre Over varme beskyttelse: køre Kortslutning mellem motor faser: køre Thermal beskyttelse: køre
bredde	45,0 mm
Højde	325,0 mm
Dybde	245,0 mm
Vægt	2,4 kg
transient overmoment	170...200 % af nominel motorvridningsmoment

## Miljø

Driftstilling	Vertikal +/- 10 grad
Produktcertificeringer	CE ATEX NOM GOST EAC RCM KC
Mærkning	CE "ATEX" UL CSA EAC RCM
Standarder	IEC 61800-5-1
elektromagnetisk kompatibilitet	Immunitetstest overfor elektrostatisk afladning Level 3 conforming to IEC 61000-4-2 Radiated radio-frekvens electromagnetic field immunity test Level 3 conforming to IEC 61000-4-3 Immunitetstest overfor hurtige elektriske transienter level 4 conforming to IEC 61000-4-4 1.2/50 µs - 8/20 µs surge immunity test Level 3 conforming to IEC 61000-4-5 Conducted radio-frekvens immunity test Level 3 conforming to IEC 61000-4-6 Voltage dips and interruptions immunity test conforming to IEC 61000-4-11
Environmental class (during operation)	Class 3C3 according to IEC 60721-3-3 Class 3S2 according to IEC 60721-3-3
Maximum acceleration under shock impact (during operation)	150 m/s <sup>2</sup> at 11 ms
Maximum acceleration under vibrational stress (during operation)	10 m/s <sup>2</sup> at 13...200 Hz

Maximum deflection under vibratory load (during operation)	1.5 mm at 2...13 Hz
Permitted relative humidity (during operation)	Class 3K5 according to EN 60721-3
volumen på køleluft	11,3 m3/h
Overspændingskategori	III
Reguleringsstøffe	Justerbar PID regulator
hastigheds nøjagtighed	+/- 10 % af nominal slip 0.2 Tn to Tn
Forureningsgrad	2
Ambient air transport temperature	-25...70 °C
Temperatur ved drift	-10...50 °C uden tab 50...60 °C med reducereing
Omgivelsestemperatur ved opbevaring	-25...70 °C

## Forpakkingsinformation

Enhedstype af pakke 1	PCE
Antal enheder i pakke 1	1
Pakke 1 Højde	8,500 cm
Pakke 1 Længde	27,500 cm
Package 1 Length	32,500 cm
Pakke 1 Vægt	2,230 kg
Enhedstype af pakke 2	P06
Antal enheder i pakke 2	24
Pakke 2 Højde	75,000 cm
Pakke 2 Bredde	60,000 cm
Pakke 2 Længde	80,000 cm
Pakke 2 Vægt	68,832 kg

## Logistik informationer

Oprindelsesland	ID
-----------------	----

## Environmental Data

Schneider Electric's mål er at opnå Net Zero-status i 2050 gennem partnerskaber med forsyningskæden, materialer med lavere påvirkning og cirkularitet via vores igangværende kampagne "Use Better, Use Longer, Use Again" for at forlænge produkternes levetid og genbrugelighed.

[Forklaring af Environmental Data >](#)

[Sådan vurderer vi produktets bæredygtighed >](#)

### Miljøfodaftryk

CO2-belastning (kg CO2 eq.) 1281

Miljøoplysning [Miljøprofil for produkt](#)

### Use Better

#### Materialer og emballage

Pakke med genbrugspap Yes

Emballage uden plast No

[EU RoHS-direktivet](#)

Proaktiv overensstemmelse (produkt ikke omfattet af EU RoHS)

SCIP-nummer C714cfa5-33e8-425e-8649-05307842d012

Reach-forordning [REACH-erklæring](#)

#### Energieffektivitet

ProduktBidragUndgået Yes

### Use Again

#### Ompakning og genfremstilling

Cirkularitetsprofil [Oplysninger om udtjent udstyr](#)

Returnering No

WEEE

 Produktet skal bortskaffes på EU's markeder efter en specifik affaldsindsamling og må aldrig ende i skraldespande

Dimensions Drawings

Dimensions

Bottom, Right and Front View

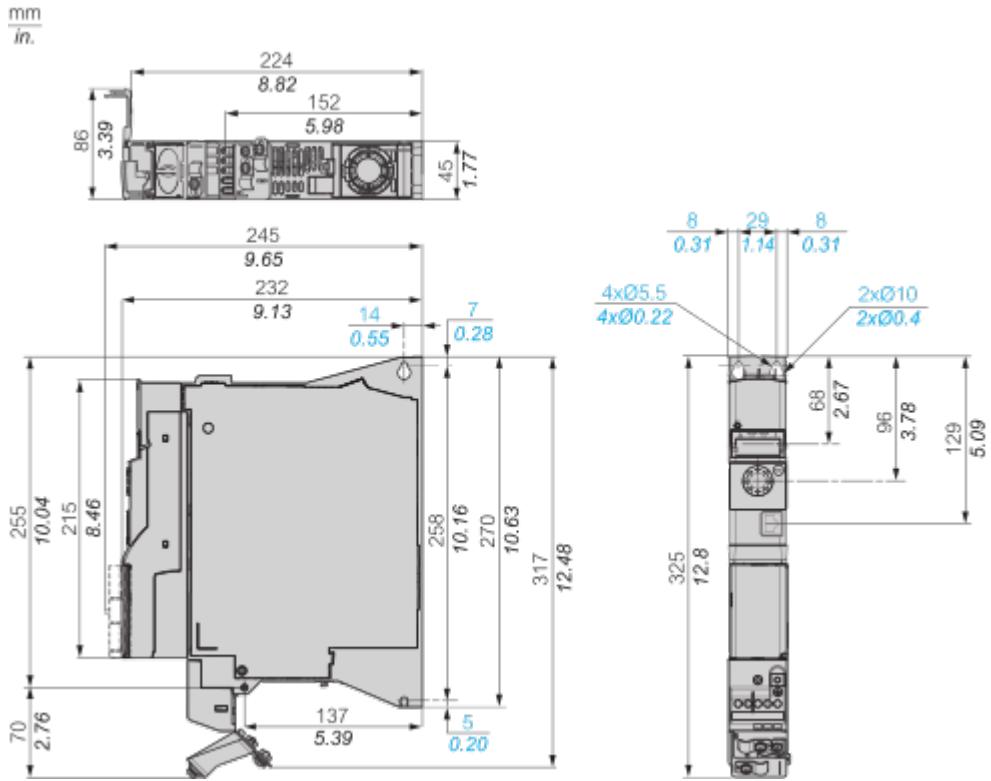



Option: Protection Device, GV2 circuit-breaker

---

**NOTE:** The product overall height dimension, including GV2 adapter and EMC plate mounted, becomes 424 mm (16.7 in.) instead of 325 mm (12.80 in.)

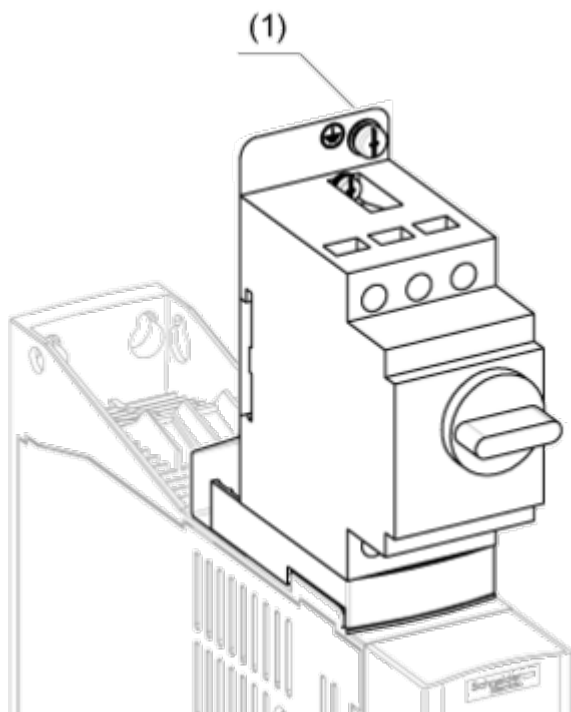

(1) Ground screw (HS type 2 - 5x12)

Connections and Schema

Connection Diagrams

Single or Three-phase Power Supply - Diagram With Line Contactor

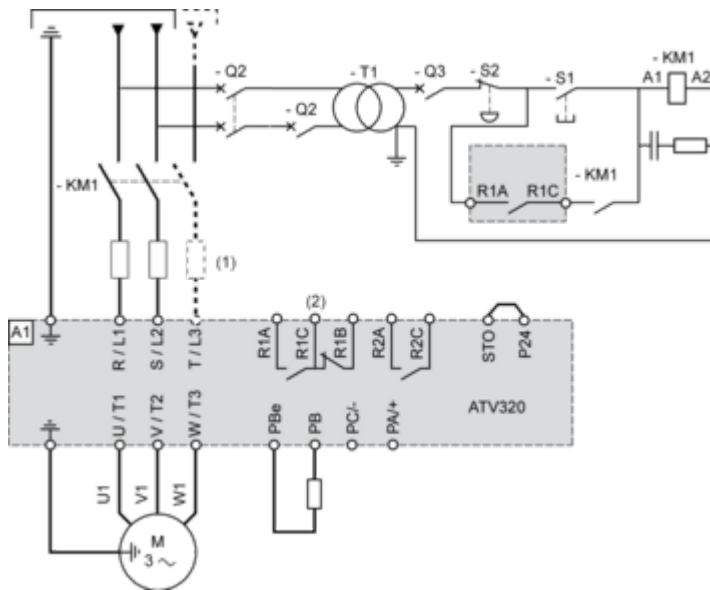

- (1) Line choke (if used)
- (2) Use relay output R1 set to operating state Fault to switch Off the product once an error is detected.

Single or Three-phase Power Supply - Diagram With Downstream Contactor

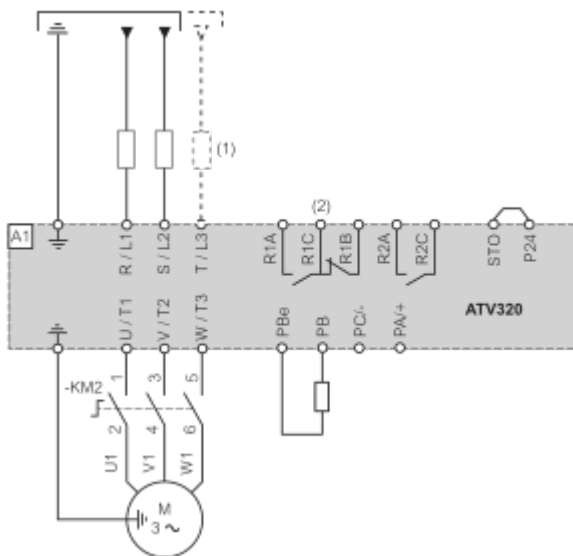

- (1) Line choke (if used)
- (2) Use relay output R1 set to operating state Fault to switch Off the product once an error is detected.

Control Block Wiring Diagram

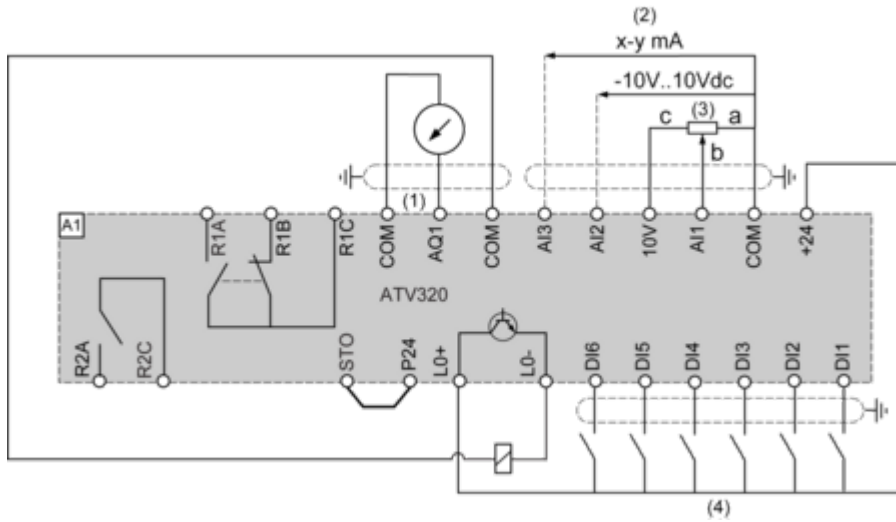

- (1) Analog output
- (2) Analog inputs
- (3) Potentiometer SZ1RV1202 (2.2 kΩ) or similar (10 kΩ maximum)
- (4) Digital Inputs - Shielding instructions are given in the Electromagnetic Compatibility section

Digital Inputs Wiring

Switch Set to SRC (Source) Position Using the Output Power Supply for the Digital Inputs

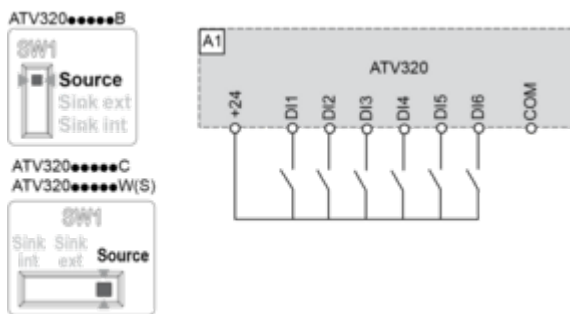

Switch Set to SRC (Source) Position and Use of an External Power Supply for the Digital Inputs

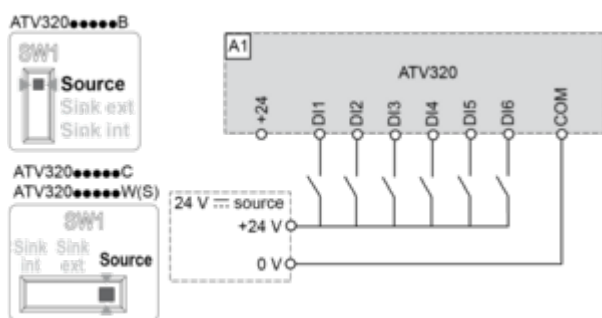

Switch Set to SK (Sink) Position Using the Output Power Supply for the Digital Inputs

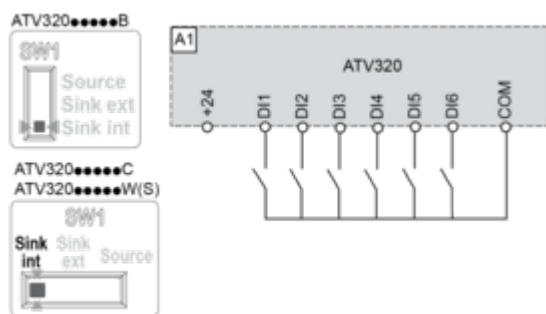

Switch Set to EXT Position Using an External Power Supply for the Digital Inputs

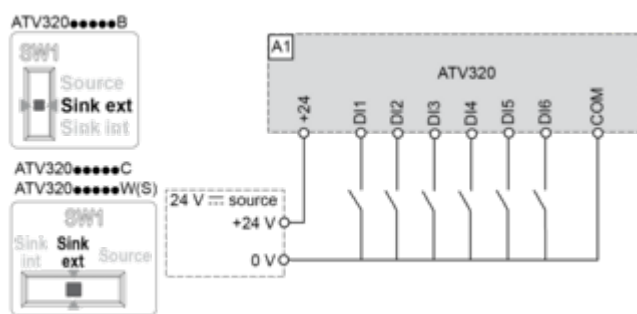

NOTE :

- STO input is also connected by default on a 24 Vdc terminal. If the external power supply is switched off, the function STO will be triggered.
- To avoid triggering the STO function when switching-on the product, the external power supply must be previously switched on.



Performance Curves

Derating Curves

---

Derating curve for the nominal drive current ( $I_n$ ) as a function of temperature and switching frequency (SF).

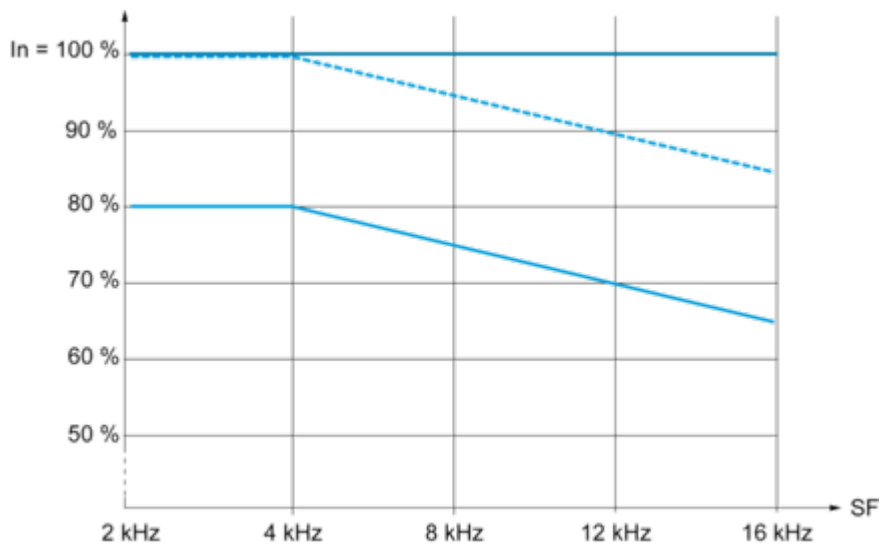

- 40 °C (104 °F) - Mounting type A, B and C
- - - 50 °C (122 °F) - Mounting type A, B and C
- 60 °C (140 °F) - Mounting type B and C

$I_n$  : Nominal Drive Current

SF : Switching Frequency

Technical Illustration

Dimensions

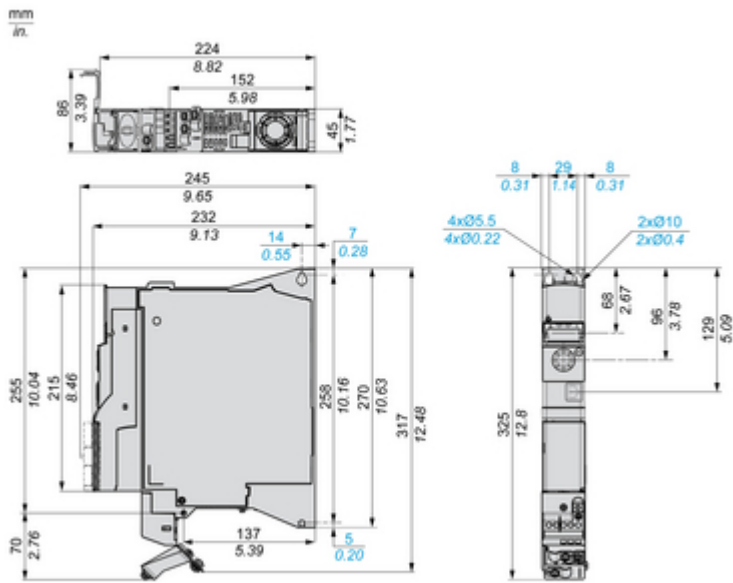

Image of product / Alternate images

Alternative

---



