

Mobile/Wall-mounted DC charging station Concise Operation Guide



1. Preface

In order to enable you to use the DC charger for electric vehicles safely and to troubleshoot in time, please read the manual carefully before use.

The charger is suitable for lithium-ion power batteries, providing energy output no greater than the rated power and maintaining high output voltage and current accuracy; the digital tube is the most important man-machine dialogue interface of the charger, the main function is to display charging voltage and current, fault status and other information in the charging process.

The charger strictly implements "GB/T20234.3-2015 Electric Vehicle Conduction Charging Connection Device Part 3: DC Charging Interface", "GB/T18487.1-2015 Electric Vehicle Conduction Charging System Part 1: General Requirements", "GB/T18487.3-2001 Electric Vehicle Conduction Charging System AC DC Charger (Station) for Electric Vehicles and the relevant requirements in GB/T27930-2015 Communication protocol between non-vehicle conduction charger and battery management system for electric vehicles" to realize intelligent communication with vehicle equipment.

This manual is only applicable to DC chargers for electric vehicles. The contents of the manual are subject to update without notice as the control software and display interface software are upgraded.

Please keep the manual in a safe place for future reference.

2. Explanation of safety matters

2.1 Charging operations should be carried out in accordance with the operating instructions provided by the Company;

2.2 It is strictly forbidden for non-professionals to open the charger cabinet at will; no private disassembly and installation is allowed;

2.3 When stopping in the middle of the charging process, the charger must be stopped by manually clicking the button and then unplugging the charging gun;

2.4 It is strictly forbidden to plug and unplug the charging gun directly during the charging process, otherwise it will burn the charging gun and the charger, or even burn the operator;

2.5 Prohibit any operation not related to charging during the charging process, only click the charger button to stop and disconnect the charging gun from the car before other operations;

2.6 Avoid fire and smoke (open flames) near the charger and pay attention to ventilation;

2.7 The fuse must be replaced with the same type of product, not with copper or iron wire instead;

2.8 There is high voltage inside the charger, there is a fault should be repaired by professionals to avoid danger;

2.9 The charger upper circuit breaker and distribution devices must be selected and installed and operated by professional electrical personnel;

2.10 It is recommended to disconnect the power supply in bad weather such as thunderstorm, if the charger is waterlogged, contact the manufacturer to finish the treatment before continuing to use.

2.11 The unit weight of the charging gun cable is large, and the long cable is easily dragged and stressed

during the actual charging process, which is not conducive to releasing the twisting force, increasing the risk of cable twisting and bulging and affecting the service life of the product. It is therefore forbidden to pull or twist the charging cable with force. When charging the charging gun cable must be smoothed and not twisted so that the charging gun holder is stressed during use.

2.12 When inserting and pulling out the charging gun, it is strictly forbidden to shake the gun from side to side and must be inserted and pulled out vertically with force.

If the following conditions occur, please turn off the power in time and notify the professional for maintenance:

- A strange noise inside the charger;
- A strange smell or smoke coming from the inside of the charger;
- no display or no response from the charger display;
- a non-recoverable fault alarm on the charger;



Note: Before powering up and running, please ensure that the equipment shell is effectively connected to the earth, otherwise there is a risk of electric shock!



Package contains:

1. One charger (input cable and charging gun connected to the body)
2. A copy of the user guide
3. The product may be in a wooden box/carton due to transport requirements, this is only an indication

3. Product shape

MC-Mobile Charger(7KW)



MC-Mobile Charger(7-20KW)



MC-Mobile Charger(30-40KW)



XC-Mobile Charger(7-40KW)



SC-Wall hanging Charger(7-40KW)



JC-Wall hanging Charger(7KW)



Pillar



4. Wall Mount Diagram



1. when you open the carton box



2. take the charger
Unscrew the two white board

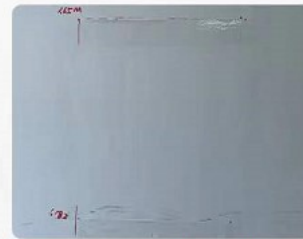

5 note size on the wall
interval 46.8cm between
the two wall board
stick the paster like the picture



6 drill hole,insert the screw



3 after unscrew the wall board



4. installation accessories shown
in the pics



7 after hang the wall
please tighten the screws



8,alignment the hole to hang the
charger on the wall,tighten the
screws

5. Diagram of the concrete foundation for the column

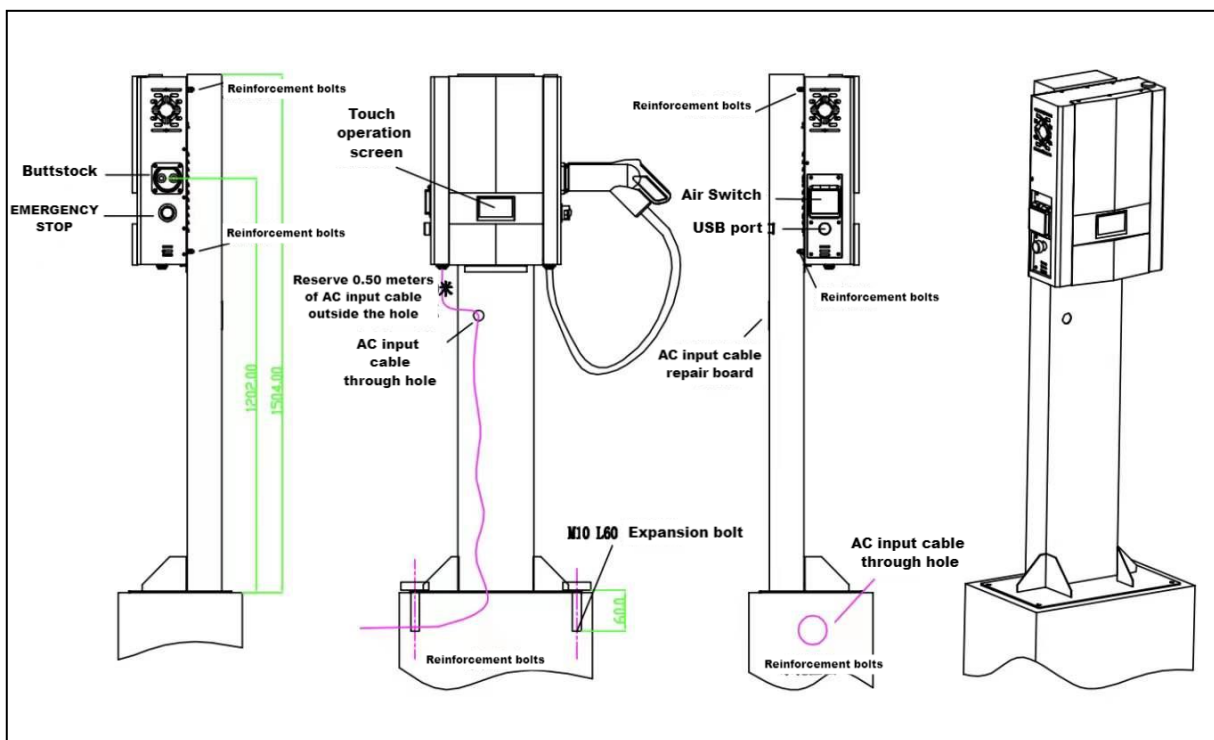
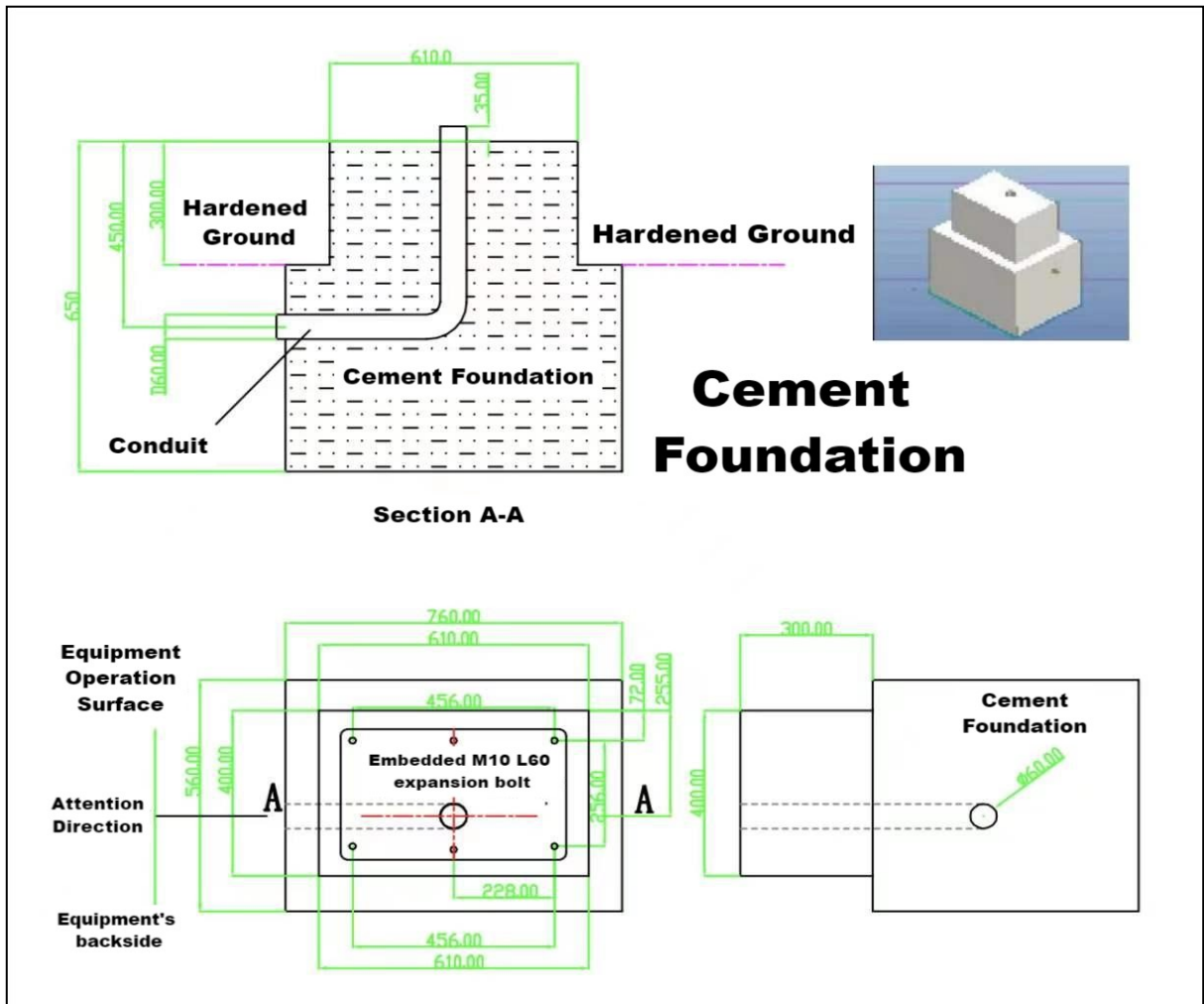

6. Basic parameters

Power	Input voltage	Output voltage	Output current
7kw	90-265VAC	200-750VDC	20A
15kw	300-465VAC	200-750VDC	37.5A
20kw	300-465VAC	200-750VDC	50A
30kw	300-465VAC	200-750VDC	75A/100A
40kw	300-465VAC	200-750VDC	100A/134A

The above parameters are for reference only. For special customization or low-voltage type, the specifications shall prevail

7. Installation procedure

7.1 Wiring before power on

- (1) If the purchased product is equipped with a plug and socket style, simply install the plug and socket directly;
- (2) Please follow the schematic diagram below if wiring is required.

Wiring diagram of single-phase 2P circuit breaker with 220V AC input cable

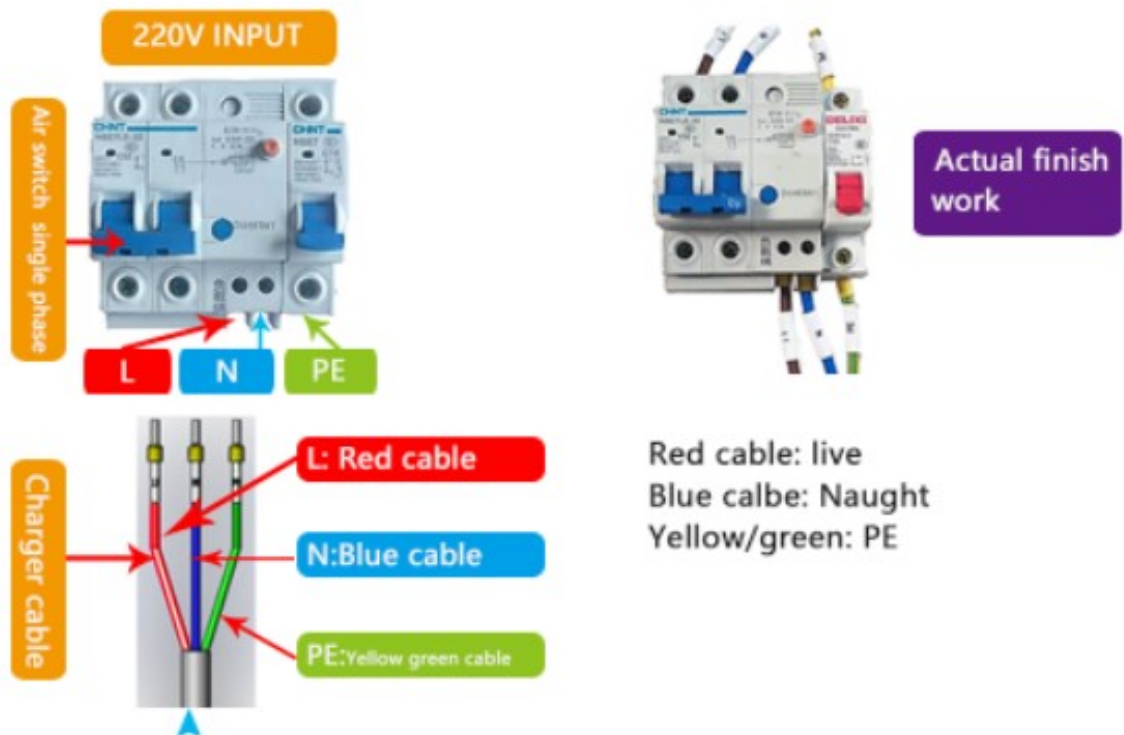

Wiring diagram of single-phase 3P circuit breaker with 220V AC input cable

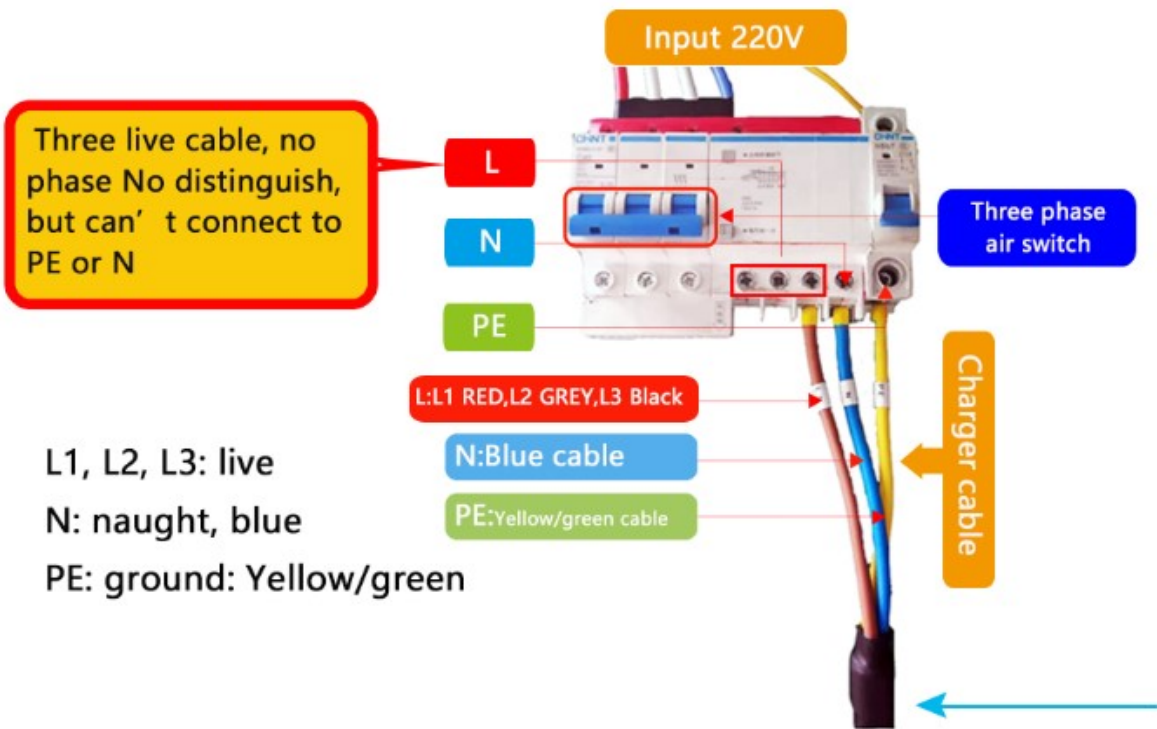

Wiring diagram of single-phase 3P circuit breaker with 380V AC input cable

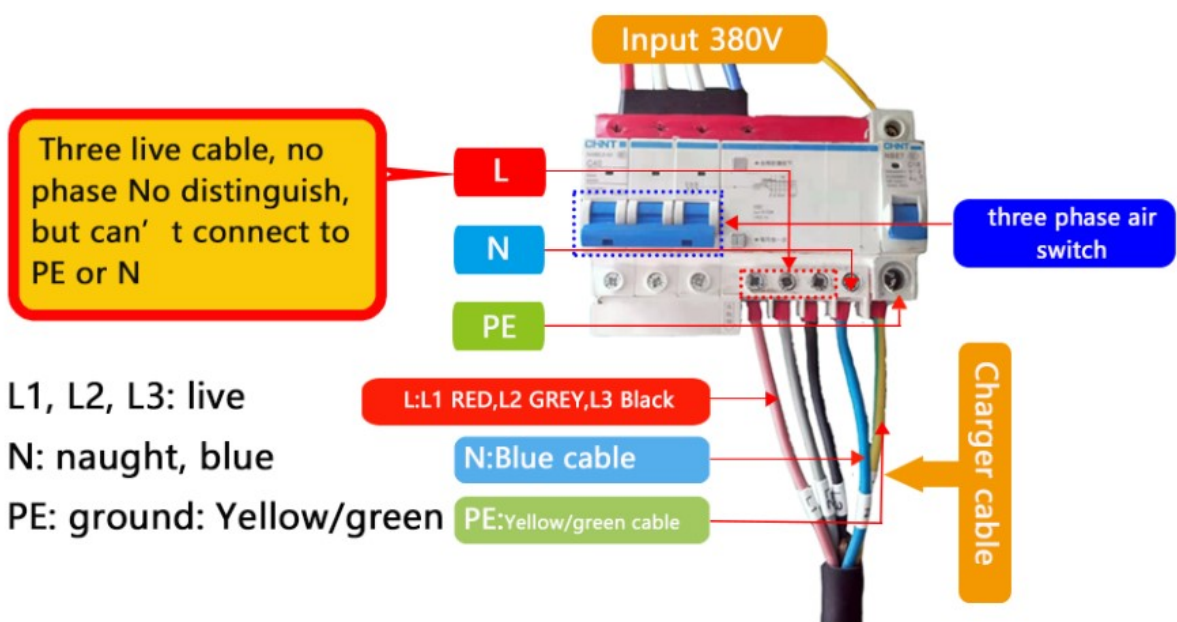

8.Wiring precautions

Power	Product specifications	Input cable specifications	External air switch requirements
7KW	Input: 220V, 32A, Output: 7kw	3x6mm ²	40A, 2P, With leakage protection
15KW	Input: 380V, 22A, Output: 15kw	5x6mm ² Copper wire	63A, 3P, With leakage protection
20KW	Input: 380V, 30A, Output: 20kw	5x6mm ² Copper wire	63A, 3P, With leakage protection
30KW	Input: 380V45A, Output: 30kw	5x10mm ² Copper wire	63A, 3P, With leakage protection
40KW	Input: 380V60A, Output: 40kw	5x16mm ² Copper wire	80A, 3P, With leakage protection

- ① Input cables can use zero and ground wires with one less specification than live wires.
- ② When wiring, strictly follow the markings on the upper line to connect to the corresponding position of the air switch, and do not connect the wrong cable;
- ③ When the AC input cable of the charger is connected to the air switch, the user air switch and the charger air switch must be placed in the closed state, and the connection must be confirmed to be correct before being opened in sequence;
- ④ The user must confirm that the load locking screw is in a locked state and must not be loose;
- ⑤ If encountering the phenomenon of tripping when pushing overhead, it is not allowed to forcefully push the brake again. The cause must be identified before pushing the brake again;
- ⑥ The grounding wire must be connected to prevent electric shock and safety of the human body under grounding conditions.

9.charger

—Digital tube+voice charging steps—

- 9.1 Connect the charging gun to the vehicle charging gun holder;
- 9.2 Turn on the air switch of the charger and power on the charging post. At this time, the power indicator is on, and the Nixie tube displays "222",
- 9.3 The gun is inserted successfully. If the digital tube displays "111", it means that the gun is inserted unsuccessfully. You need to plug it again until the Nixie tube displays "222".
- 9.4 Press the start button switch, and the operation flashes to start charging. The contents displayed on the Nixie tube during charging are described as follows:

U-Voltage

C-Current

c-battery SOC

E-Fault codes

"U600" REPRESENT OUTPUT VOLTAGE IS 600V

"C20.0" REPRESENT CURRENT IS 20A



"c050" REPRESENT BATTERY SOC IS 50%

"E070" REPRESENT FAULT CODES



—Screen charging steps—



Step 1: Plug in the charging gun



Step 2: Switch the input line to ON



Step 3: Turn ON the back of the charger to ON



Step 4: Welcome charging interface

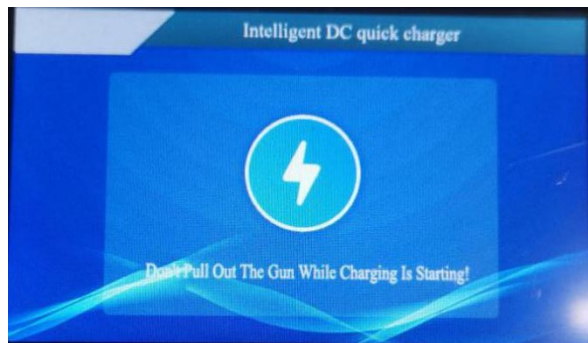

Step 5:connecting

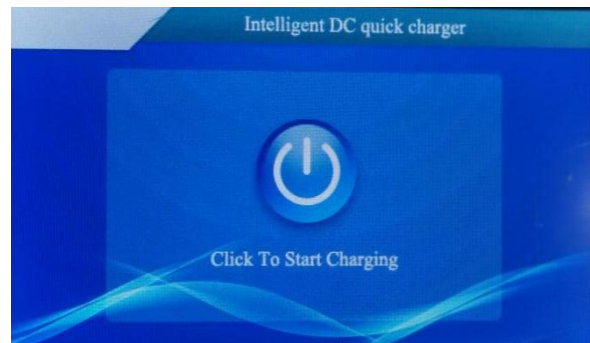

Step 6: Enter the start up interface

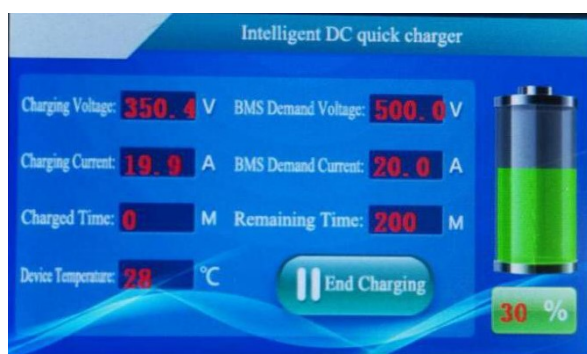

Step 7: Charging interface

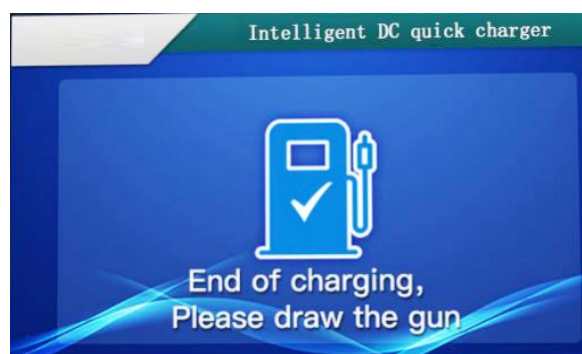

Step 8: Charge finished, draw gun, charge completed

10. Fault display interface

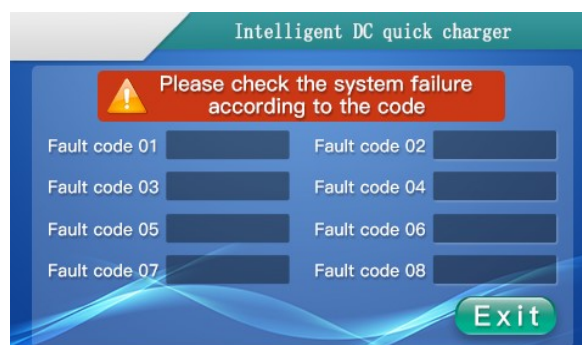
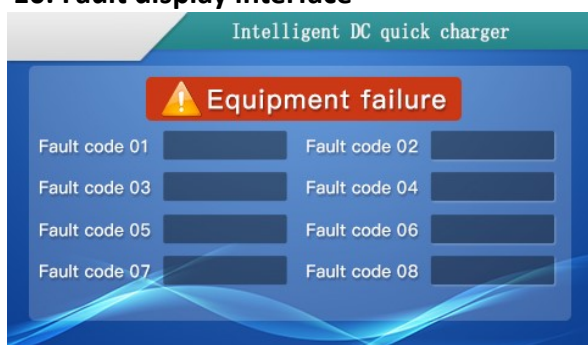

11. Routine maintenance table

Checkcontent	Check the method	Maintenance cycle
General operating status and environment of the system	<ol style="list-style-type: none"> 1. Observe whether the components, circuit and device structure of the charger are damaged or deformed; 2. Listen to whether there is any abnormal sound when the charger is running; 3. Check whether the data display on the touch screen is normal. 4. Check whether the switch, contactor, circuit breaker, and fan are normal. 5. Check whether the heat of the charger shell is normal; 6. Observe whether the inlet and outlet air is normal; 7. Check the humidity and dust around the charger. <p>Attention! Intake ventilation must be checked. If the module is not cooled effectively, it will fail due to overheating.</p>	Once every six months
System clean	<ol style="list-style-type: none"> 1. Check the cleanliness of circuit boards and components; 2. Check the temperature and dust of the internal charging module. Remove the module and clean it if necessary. 	Once every six months to once a year (depending on the dust content of the environment)
Power circuit connection	<ol style="list-style-type: none"> 1. Check whether the power cable and control cable are damaged, especially whether the skin in contact with the metal surface is cut; 2. Check whether the insulation bandage of the power cable wiring terminal is off. 	Six months after the first commissioning, and then once every six months to a year
Cooling fan maintenance and replacement	<ol style="list-style-type: none"> 1. Check whether there are cracks in fan blades; 2. Listen to whether there is abnormal vibration sound when the fan is running; 3. Replace the fan in time if it is abnormal. 	Once a year
Circuit breaker maintenance	<ol style="list-style-type: none"> 1. Check the corrosion of all metal components regularly (every six months); 2. Annual inspection of contactor to ensure good mechanical operation. 	Once every six months to a year
Safety features	<ol style="list-style-type: none"> 1. Check the function of emergency stop button and stop button; 2. Simulated shutdown. 	Once every six months to a year

12. Precautions for Use

- 12.1 In the normal charging process, it is strictly forbidden to plug or remove the charging gun with electricity;
- 12.2 To end charging, you must first press the "Start/Stop" button, pull the gun, and then disconnect the charger to disconnect the mains;
- 12.3 Do not pull the locked gun out of the socket by brute force to avoid conductive materials such as metal foreign bodies entering the device.
- 12.4 Non-professionals do not open the charger shell to avoid damage to the charger;
- 12.5 Pay attention to the BMS power supply voltage of 12V or 24V, and select the corresponding charging model number.
- 12.6 The charger is equipped with a standard input cable. Users need to connect an external circuit breaker to ensure that the input PE cable is reliably grounded.
- 12.7 Only when the input power distribution capacity is not less than the rated power of the charger, can the charger be charged at full power.
- 12.8 Dc charging gun is standard, no need to install it separately;
- 12.9 Indoor drying is forbidden to be used in rainwater environment;
- 12.10 If there is a heat source near the charger, please move it as far as possible and take the surrounding space into full consideration to facilitate heat dissipation;
- 12.11 Avoid steam, dust and metal dust;
- 12.12 Keep away from flammable, explosive and corrosive gases and liquids;
- 12.13 Stay away from electromagnetic interference sources.

13. Fault code table

Fault code	Corresponding description
0	Normal state
1	Access control failure
2	Lightning arrester
3	Emergency stop fault
4	The electronic lock of the charging interface is stuck and the actuation is faulty
5	AC circuit breaker
6	Charging pile overtemperature
7	Over temperature fault of charging interface
8	DC output contactor adhesion fault
9	Misoperation of DC output contactor
10	Parallel relay adhesion
11	Parallel relay actuation / misoperation
12	AC input contactor / adhesion
13	Misoperation of AC input contactor
14	Insulation module fault
15	Discharge circuit fault
16	Auxiliary power supply
17	Fuse Fault
18	Flooding fault
19	Smoke sensor fault
20	Fan fault
21	Input overvoltage
22	Input undervoltage
23	Output voltage overvoltage
24	Output voltage undervoltage
25	Output current overcurrent
26	CC disconnection control pilot fault
27	Insulation detection fault

28	Battery reverse connection fault
29	EV voltage is greater than 10V before starting insulation
30	The maximum allowable charging voltage of the battery is less than the minimum output voltage of the charger
31	EV voltage deviation before precharge is greater than 5%
32	EV current voltage is less than the minimum output voltage of charger
33	EV current voltage is greater than the maximum output voltage of charger
34	EV communication timeout
35	BRM message receiving timeout
36	BRM message data item exception
37	BCP message receiving timeout
38	BCP message data item exception
39	Bro message (0x00) receiving timeout
40	Bro message (0XAA) receiving timeout
41	Bro message (0XAA is sent first and 0x00 is sent later)
42	Battery charging demand message (BCL) timeout
43	Total battery charge status message (BCS) timeout
44	Power battery status information (BSM) timeout
45	Voltage overvoltage of single power battery in BSM message
46	The voltage of single power battery in BSM message is too low
47	The SOC in the BSM message is too high
48	SOC in BSM message is too low
49	Charging overcurrent in BSM message
50	The temperature of power battery in BSM message is too high
51	Abnormal insulation state of power battery in BSM message
52	Abnormal connector connection status in BSM message
53	EV overtemperature, the temperature exceeds the maximum allowable temperature
54	EV battery terminal voltage is greater than the maximum allowable charging voltage of the battery
55	EV overcurrent
56	Cell overvoltage
57	Pause charging timeout
58	Charging module fault
59	AC input fault of charging module
60	AC overvoltage of charging module
61	AC undervoltage of charging module
62	AC phase failure of charging module
63	Charging module DC short circuit
64	DC overcurrent of charging module
65	DC overvoltage of charging module
66	DC undervoltage of charging module
67	Charging module overtemperature
68	Charging module overtemperature
69	Charging module fan fault
70	TCU heartbeat timeout
71	Startup status response timeout
72	PCM access control fault
73	PCM flooding fault
74	Communication timeout between DC charging main control module and power control module
75	Communication timeout between power control module and switch module
76	Switch module fault (only used for DC pile)
77	Switch module fault
100	Communication failure of card reader
101	Meter communication fault

102	Transaction full
103	Transaction record storage failed
104	Platform registration verification failed
105	Program file verification failed
106	Power failure of charging unit
107	Charging service suspended
108	The charging point is not connected with the vehicle
109	Communication timeout between charger and charging control unit
110	Data validity verification failed
200	success
201	Data validity verification failed
202	Communication timeout
203	Version Verification not completed
204	Issuing charging parameters is not completed
205	Charging point suspended
206	Working state of charging pile: charging
207	Charging point suspended
208	The charging pile is not connected with the vehicle
209	Abnormal emergency stop
210	Access control failure
211	Lightning arrester fault
212	Smoke sensing fault
213	Charging pile overtemperature
214	Over temperature of charging interface
215	Charging interface electronic lock fault
216	Insulation detection fault
217	Reverse battery connection
218	BMS communication timeout
219	Input high voltage circuit breaker fault molded case
220	Input high voltage contactor actuation / misoperation
221	Input high voltage contactor adhesion fault
222	Misoperation of output high-voltage contactor
223	Output high voltage contactor adhesion fault
224	Output high voltage fuse fault
225	Misoperation of parallel contactor
226	Parallel contactor adhesion fault
227	Discharge circuit fault
228	Auxiliary power failure
229	Charger module fault
230	Input power failure (overvoltage, undervoltage, overcurrent)
231	Output voltage overvoltage fault
232	Output voltage undervoltage fault
233	Output current overcurrent fault
234	Output short circuit fault
235	No remaining charger module available
236	Other faults of charging pile (reserved)
237	Access control failure (charging cabinet, DC pile)
238	Flooding fault (charging pile)
239	Flooding fault (DC pile of charging cabinet)
240	Communication timeout between DC charging main control module and power control module (only used for DC pile)
241	Communication timeout between power control module and switch module (only used for DC pile)
242	Switch module fault (only used for DC pile)

243	Other faults of charging pile
300	success
301	Control pilot failure during charging
302	Communication timeout between charging controller and charging control unit
303	Emergency stop button action fault
304	Access control failure
305	Lightning arrester fault
306	Smoke sensing fault
307	AC input circuit breaker fault
308	AC input contactor actuation / misoperation fault
309	AC input contactor adhesion fault
310	AC input fault (overvoltage, undervoltage, phase loss, overcurrent)
311	Over temperature fault of charging pile
312	Over temperature fault of charging interface
313	Charging interface electronic lock fault
314	Insulation monitoring fault
315	Battery polarity reverse connection fault
316	DC output contactor actuation / misoperation fault
317	DC output contactor adhesion fault
318	DC output fuse fault
319	Parallel contactor actuation / misoperation fault
320	Parallel contactor adhesion fault
321	Discharge circuit fault
322	Auxiliary power failure
323	Charger module fault
324	DC output voltage overvoltage fault
325	DC output voltage undervoltage fault
326	DC output current overcurrent fault
327	DC output short circuit fault
328	The maximum allowable charging voltage of the battery is less than the minimum output voltage of the charger
329	Outside voltage of DC output contactor before insulation monitoring ≥ 10 V
330	Before starting charging, the difference between the external voltage of the DC output contactor and the battery voltage of the communication message is more than $\pm 5\%$
331	Before starting charging, the voltage outside the DC output contactor is less than the minimum output voltage charger
332	Before starting charging, the voltage outside the DC output contactor is greater than the maximum output voltage charger
333	The battery terminal voltage is greater than the maximum allowable charging voltage of the battery
334	BRM message receiving timeout
335	BRM message data item exception
336	BCP message receiving timeout
337	BCP message data item exception
338	Bro message (0x00) receiving timeout
339	Bro message (0XAA) receiving timeout
340	Other faults of charger
341	BCL message receiving timeout
342	BCS message receiving timeout
343	Access control failure (charging cabinet, only for DC pile)
344	Flooding fault (charging pile)
345	Flooding fault (charging cabinet, only for DC pile)
346	Communication timeout between DC charging main control module and power control module
347	Communication timeout between power control module and switch module
348	Switch module fault
349	BMS communication protocol version mismatch

350	Other faults of charger
400	Unknown reason
401	The charging control unit stops normally
402	The charging control unit terminates due to its own fault
403	The charging control unit judges that the charging controller is stopped due to fault
404	Start completion status frame confirmation timeout fault termination
405	Control pilot failure during charging
406	Communication timeout between charging controller and charging control unit
407	Timeout during charging of charging pile
408	Emergency stop button action fault
409	Access control failure
410	Lightning arrester fault
411	Smoke sensing fault
412	AC input circuit breaker fault
413	AC input contactor actuation / misoperation fault
414	AC input contactor adhesion fault
415	AC input fault (overvoltage, undervoltage, phase loss, overcurrent)
416	Over temperature fault of charging pile
417	Over temperature fault of charging interface
418	Charging interface electronic lock fault
419	DC output contactor actuation / misoperation fault
420	DC output contactor adhesion fault
421	DC output fuse fault
422	Parallel contactor actuation / misoperation fault
423	Parallel contactor adhesion fault
424	Discharge circuit fault
425	Auxiliary power failure
426	Charger module fault
427	DC output voltage overvoltage fault
428	DC output voltage undervoltage fault
429	DC output current overcurrent fault
430	DC output current overcurrent fault
431	Battery charging demand message (BCL) timeout
432	Total battery charge status message (BCS) timeout
433	Power battery status information (BSM) timeout
434	Voltage overvoltage of single power battery in BSM message
435	The voltage of single power battery in BSM message is too low
436	The SOC in the BSM message is too high
437	SOC in BSM message is too low
438	Charging overcurrent in BSM message
439	The temperature of power battery in BSM message is too high
440	Abnormal insulation state of power battery in BSM message
441	Abnormal connector connection status in BSM message
442	BMS normally terminates charging
443	BMS abnormally terminates charging
444	Charging point judges other abnormal termination of BMS
445	Other faults of charging pile
446	Other faults of charging pile
500	Communication failure of billing meter
501	Power failure of charging unit
502	Total charging time exceeds the maximum allowable time
503	SOC full stop

504	User card swiping termination
505	User remote (mobile phone, website) termination
506	User authentication code termination
507	Insufficient account balance
508	Time meets charging strategy
509	The electric quantity meets the charging strategy
510	Amount meets charging strategy
511	SOC meets charging strategy