

# Multisealant GR

Firestop Intumescent Graphite

European  
Technical Assessment  
ETA 23/0055



Technical Data Sheet

**MULCOL**  
INTERNATIONAL

# Contents

<b>Product specification</b>	3
■ Advantages	
■ Applications	
■ Packaging	
<b>1. Technical data</b>	4
<b>2. Acoustic properties</b>	5
<b>3. Installation Manual</b>	5
<b>4. Pipe Insulation (Configuration)</b>	6
<b>5. Permitted Insulation Materials</b>	6
<b>6. Performance Summary</b>	7
<b>7. Electrical room services</b>	9
<b>8. Actually tested solutions</b>	10
<b>9. Pipe Support Penetrations</b>	10
<b>10. Test Configuration</b>	10
<b>11. Building Element Properties</b>	12
<b>12. Available Documents</b>	12

**MULCOL**  
INTERNATIONAL

Pragmatic, effective  
and applicable  
solutions



# Multisealant GR

Firestop Intumescent Graphite



**Fire resistance**  
≤ 240 minutes



**Acoustic insulation**  
Rw 55 dB



**Working life**  
25 years

## Firestop Intumescent Graphite

Multisealant GR is a graphite-based sealant that foams and insulates when heated up for the fire-resistant sealing of gaps around cable and pipe penetrations. In the event of fire, this sealant prevents fire and smoke from spreading through fire-resistant walls and floors. Multisealant GR was developed to seal inaccessible penetrations and for places where traditional fire-resistant sealants are insufficient, for instance in the case of large plastic pipes.

Multisealant GR forms part of the Mulcol® Penetration Seal System.

### Advantages

- ✓ Fire resistance ≤ 240 minutes
- ✓ CE-certified
- ✓ High acoustic insulation
- ✓ Environmentally and user-friendly
- ✓ Quick and easy application
- ✓ Fast-drying
- ✓ Halogen-free
- ✓ Working life of 30 years

### Application

- ✓ Solid walls, stone and wood
- ✓ Solid floors, stone and wood
- ✓ Lightweight partition walls
- ✓ Stone wool firewalls
- ✓ Cables, cable bundles, cable trays
- ✓ Meter box penetrations
- ✓ Plastic pipes
- ✓ Multilayer and metal pipes
- ✓ Gas and air-conditioning pipes

### Packaging

	Contents	Box	Pallet	Pallet	Article number
Cartridge	310 ml	12 pieces	128 boxes	1536 pieces	201012310

# 1. Technical Data

<b>EAN-code</b>	8719324470032
<b>Condition</b>	Ready to use, water-based sealant
<b>Colour</b>	Dark grey (may become darker after hardening)
<b>Shelf life</b>	18 months in unopened packaging at a temperature between +5°C and +30°C
<b>Transportation- storage temperature</b>	+5 °C to +30 °C
<b>Application temperature</b>	+5 °C to +30 °C
<b>Temperature resistance</b>	-15 °C to +75 °C
<b>Film formation</b>	After max. 30 minutes
<b>Non- adhesive</b>	After max. 60 minutes
<b>Completely hardened</b>	3 to 5 days, depending on the thickness and the temperature
<b>Density</b>	1.47 - 1.57 g/cm <sup>3</sup>
<b>Reaction temperature</b>	Approx. +150 °C
<b>Category of use<sup>1)</sup></b>	Type Z <sub>2</sub> conform EAD 350454-00-1104
<b>Recoatable<sup>2)</sup></b>	Yes
<b>Suitable for smoke-tight sealing of penetrations</b>	S <sub>a</sub> en S <sub>200</sub> conform NEN 6075
<b>Acoustic properties</b>	12mm depth + 15mm backing: R <sub>s,w</sub> (C;Ctr) = 55 (-2 ; -9) dB and R <sub>s,max,w</sub> (C;C <sub>tr</sub> ) = 58 (-5 ; -13) dB
<b>Fire class</b>	E in accordance with EN 13501-1
<b>VOC content</b>	<1 g/L
<b>Approvals</b>	ETA 23/0055
<b>Compatibility</b>	Suitable for use with most material
<b>Function retention</b>	25 years

### <sup>1)</sup> Permissible environmental conditions

Joint sealant for use in interior conditions with humidity of < 85% RV without temperatures below 0 °C and without exposure to rain and/or UV (TR 024, type Z<sub>2</sub>).

### <sup>2)</sup> Recoatable

Multisealant GR firestop sealant is paintable with most water-based paint systems.

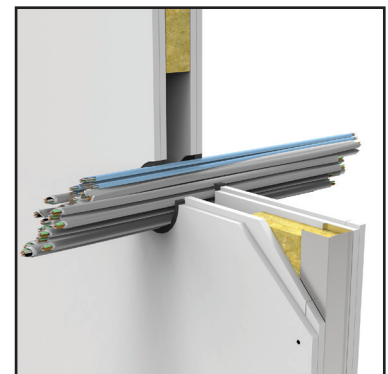
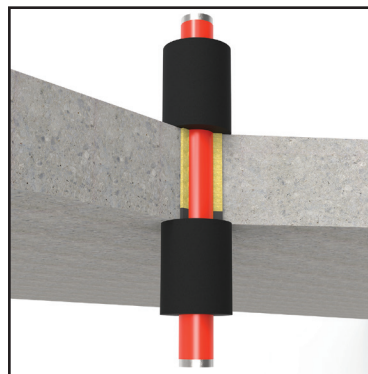

## Usage table per cartridge of 310 ml

Joint width	10 mm	15 mm	20 mm	25 mm	30 mm	40 mm	50 mm	60 mm	80 mm	100 mm
Joint depth 12.5 mm	2.45 m <sup>1</sup>	1.65 m <sup>1</sup>	1.20 m <sup>1</sup>	1.00 m <sup>1</sup>	0.80 m <sup>1</sup>	0.60 m <sup>1</sup>	0.50 m <sup>1</sup>	0.40 m <sup>1</sup>	0.30 m <sup>1</sup>	0.25 m <sup>1</sup>
Joint depth 15 mm	2.05 m <sup>1</sup>	1.35 m <sup>1</sup>	1.00 m <sup>1</sup>	0.80 m <sup>1</sup>	0.65 m <sup>1</sup>	0.50 m <sup>1</sup>	0.40 m <sup>1</sup>	0.30 m <sup>1</sup>	0.25 m <sup>1</sup>	0.20 m <sup>1</sup>
Joint depth 25 mm	1.20 m <sup>1</sup>	0.80 m <sup>1</sup>	0.60 m <sup>1</sup>	0.50 m <sup>1</sup>	0.40 m <sup>1</sup>	0.30 m <sup>1</sup>	0.25 m <sup>1</sup>	0.20 m <sup>1</sup>	0.15 m <sup>1</sup>	0.10 m <sup>1</sup>

## 2. Acoustic properties

Multisealant GR has been tested EN ISO 10140-2. The same or higher sound insulation can be achieved with a deeper or double-sided seal or by applying backing material. The sound insulation value only applies to the sealant and not to other elements in the building structure.

✓ With one-sided seal 12 mm deep, 15 mm backing: RW 55 dB

## 3. Installation Manual



**1**

Make sure that the service penetration and the gap are free from dust, dirt and grease. Moisten the structure, if necessary.



**2**

Apply Multisealant GR generously in the gap to prevent air bubbles<sup>1)</sup>.

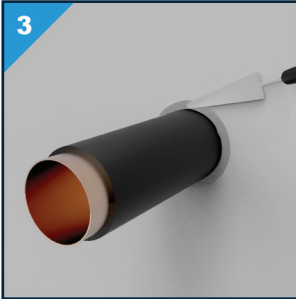

**3**

Smooth the joint with a damp spatula or filler knife.

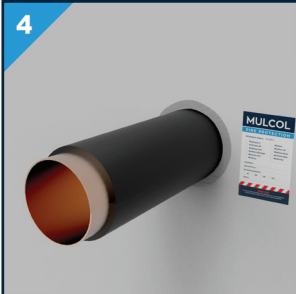

**4**

Fill in the conformity statement and paste it next to the fireproof seal.

<sup>1)</sup>When using backing, cut it slightly wider than the joint width and make sure it is applied to the correct depth in the joint.



For use and for more information about an application, refer to the Mulcol documentation, local and international approvals.

See the **Mulcol Fire Protection app** for the correct application in combination with fire resistance, or use our **selector** at [www.mulcol.com](http://www.mulcol.com).

## 4. Pipe Insulation (Configuration)

Insulations serve different functions and can therefore be arranged around pipes in different manners. This must be taken into account when applying fire stopping seals on these pipes.

Possible configurations are shown below:

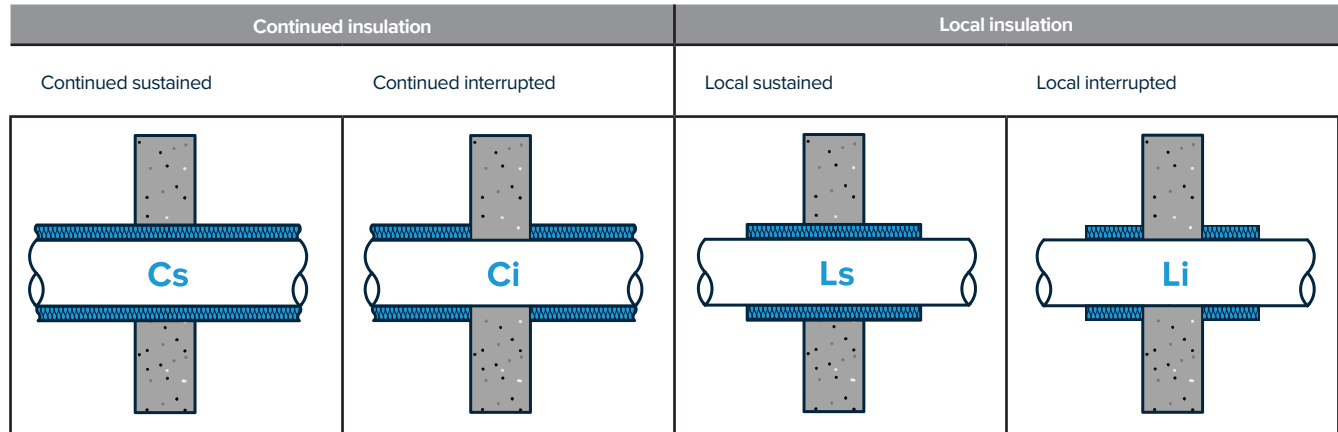

## 5. Permitted Insulation Materials

Multisealant GR firestop and (in case of heat) intumescent sealant has been extensively tested with various insulation materials; the table below shows the permitted insulation materials. For principle details, refer to the Multiselector and our test reports:

ETA 23/0055

Insulation type	Pipe type	Permitted <sup>1)</sup>
<b>Elastomeric insulaion</b> Fire class B <sub>s</sub> -s3, d0 or B-s3, d0, In accordance with EN 13501-1	<ul style="list-style-type: none"> <li>✓ Multilayer pipes</li> <li>✓ Copper pipes</li> <li>✓ (Stainless) steel pipes</li> <li>✓ Cast iron pipes</li> </ul>	<ul style="list-style-type: none"> <li>✓ AF/Armaflex</li> <li>✓ SH/Armaflex</li> <li>✓ Kaiflex ST</li> <li>✓ Kaiflex KK plus s2</li> <li>✓ K-Flex EC</li> <li>✓ K-Flex EC AD</li> <li>✓ K-Flex EC</li> <li>✓ K-Flex ST</li> <li>✓ K-Flex ST/SK</li> <li>✓ K-Flex ST Frigo</li> <li>✓ K-Flex SRC</li> <li>✓ K-Flex SRC Eco</li> </ul>
<b>PIR/PUR insulation</b> Fire class E, in accordance with EN 13501-1	<ul style="list-style-type: none"> <li>✓ Copper pipes</li> <li>✓ (Stainless) steel pipes</li> <li>✓ Cast iron pipes</li> </ul>	<ul style="list-style-type: none"> <li>✓ Insul-Phen</li> <li>✓ Insul-Pirplus</li> <li>✓ Insul-Pir 33</li> <li>✓ Kingspan Tarecpir M1</li> <li>✓ Kingspan Tarecpir CR</li> <li>✓ Kingspan Tarecpir B2</li> <li>✓ Kingspan Tarecpir HT</li> <li>✓ Kingspan Tarecpir HD</li> <li>✓ Kingspan Kooltherm FM</li> </ul>
<b>Miscellaneous thermal insulation</b> Fire class Cl-s1-d0, in accordance with EN 13501-1	<ul style="list-style-type: none"> <li>✓ Multilayer pipes</li> </ul>	<ul style="list-style-type: none"> <li>✓ PE-Foam o.e.</li> </ul>

<sup>1)</sup> Insulation materials must have at least the same fire class as tested in accordance with EN 13501-1.

## 6. Performance Summary

Always refer to ETA 23/0055 for the appropriate application and classification.

### Pipe penetrations in lightweight partition walls, solid walls and floors

Type of service	Size Ø [mm]	Isolation type	Construction				Classification minutes
			FW-100/ MW-100	Schacht	MW-150	MV-150	
Plastic pipes	≤ 50	n.a.		✓			≤ EI 45-U/U
	≤ 110				✓		≤ EI 240-U/C
	≤ 160		✓		✓	✓	≤ EI 120-U/C
				✓		≤ EI 180-U/C	
Plastic pipes with cables	≤ 110		✓	✓	✓	≤ EI 120-U/C	
Fibre composite pipes	≤ 90	Elastomeric	✓		✓		≤ EI 60-C/U
	≤ 16	n.a.		✓			≤ EI 60-C/U
Multilayer pipes	≤ 32 max 2 piece	n.a.		✓			≤ EI 90-C/U
		PE-foam		✓			≤ EI 45-C/U
	≤ 32	PE-foam	✓		✓	✓	≤ EI 120-U/C
	≤ 40	n.a.	✓		✓	✓	≤ EI 120-U/C
	≤ 75	Elastomeric	✓		✓	✓	≤ EI 90-C/U
Copper, cast iron and steel pipes	≤ 60.3	n.a.	✓		✓	✓	≤ EI 90-C/U
	≤ 114.3	Elastomeric	✓		✓	✓	
		Phenolic	✓		✓		≤ EI 60-C/U
	≤ 219.1	PIR	✓		✓		≤ EI 120-U/C
Gas pipes	≤ 60.3	Multitherm Bandage	✓		✓		
Air conditioning piping set	≤ 70	PE-foam	✓		✓		

#### Permitted plastic pipes (or equivalent)

- PE(-HD), PE-X, ABS, SAN+PVC, PP, PVC(-U/-C) buizen

#### Permitted sound-proofing pipes (or equivalent)

- Coes PhoNoFire, Coestilen BluePower, Geberit Silent PP, Geberit Silent dB 20
- Girpi Friaphon, Marley Silent, Pipelife Master 3, PhonEX AS
- Poloplast POLO-KAL NG, Poloplast POLO-KAL 3S, Skolan dB, Raupiano Plus
- Valsir Triplus, Wavin SiTech+, Wavin AS, DykaSono, Uponor Decibel

#### Permitted multilayer pipes (or equivalent)

- Alpex DUO, Valsir Pexal, Valsir Mixal en APE Plain (PE-Xb/AL/PE-Xb)
- Geberit Mepla en Uponor Unipipe (PE-RT/AL/PE-RT)
- Henco en Uponor (PE-Xc/AL/PE-Xc)
- Uponor, REHAU (PE-Xa) en REHAU (PE-Xc)
- SP Superpipe en POLYGON PEX (PE-X/AL/PE-X)
- Valsir Pexal en Valsir Mixal (PE/AL/PE-Xb)
- Wavin Tigris, Protecta-Line System en Alpex F50 Profi (PE-X/AL/PE)

#### Permitted fibre composite pipes (or equivalent)

- Aquatechnik Fusio PP-R 80, Aquatechnik Fusio PP-RCT,
- Aquatherm Blue-S, Aquatherm Blue-MF, Aquatherm Red-MF, Aquatherm Green-MF, Aquatherm Green-MS,
- Aquatherm Green-S, Aquatherm Lilac-S, Aquatherm Grey-MS en Aquatherm Orange M,
- Bänninger PP-R, Bänninger Climatec PP-RCT en Bänninger Watertec PP-RCT

#### Permitted elastomeric insulation type (or equivalent)

- Reaction to fire class ≤ B-s1, d0 - e.g. ArmaFlex Ultima, Kaiflex KK Plus S1
- Reaction to fire class ≤ B-s2, d0 - e.g. ArmaFlex AF EVO, Kaiflex KK Plus S2 / ST, K-Flex ST
- Reaction to fire class ≤ B-s3, d0 - e.g. ArmaFlex AF / XG / SH, K-Flex H
- Reaction to fire class ≤ C-s2, d0 - e.g. Kaiflex HT S2
- Reaction to fire class ≤ D-s3, d0 - e.g. ArmaFlex NH / SH / HT
- De isolaties mogen ook een BL, CL or DL classificatie hebben (linear insulation).

## Elektrakabels in lichte scheidingswanden, massieve wanden en -vloeren

Cable (trays)	Size Ø [mm]	Construction			Classification minutes
		FW-100/ MW-100	Shaft	MW-150 MV-150	
Cable trays	All			✓	≤ EI 180
Cables	≤ 14		✓		≤ EI 90
	≤ 21			✓	≤ EI 180
	≤ 25	✓		✓	≤ EI 60
Cable bundle	≤ 100	✓		✓	≤ EI 90
				✓	≤ EI 90
Plastic pipes with cable(s)	≤ 16	✓		✓	≤ EI 60-U/U
Plastic pipes in bundle with cables	≤ 16 max 8 pieces	✓		✓	≤ EI 90-U/U
Plastic pipes in bundle with cables	≤ 19 max 2 pieces		✓		≤ EI 90-U/U
Plastic pipes in bundle with cables	≤ 25 max 2 pieces		✓		≤ EI 45-U/C

FW-100: Light partition wall, thickness 100 mm

MW-100: Solid wall, thickness 100 mm

MV-150: Solid floor, thickness 150 mm

Ø [mm] Diameter of the penetration

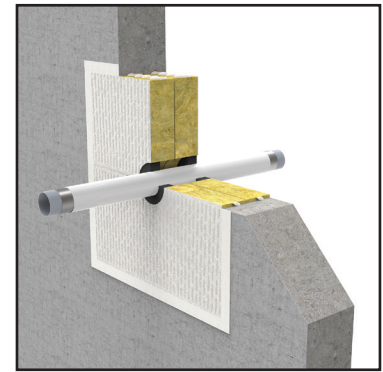
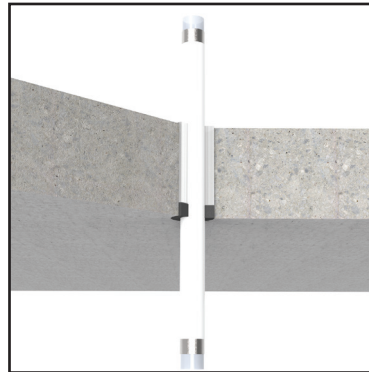

## 7. Electrical room services

Multisealant GR fire-resistant and intumescent sealant has been tested in accordance with EN 1366-3 in concrete floors with a thickness of at least 150 mm. Meter box penetrations are easy to finish with Multisealant GR sealant. A number of common penetrations are listed in the table below. For all current tested solutions with Multisealant GR, please refer to the Multiselector. Always consult ETA 23/0055 for the appropriate application and classification.

Meter cabinet service	Size Ø [mm]	Multisealant GR	Plastic casing pipe		Backing	MV-150	Classification minutes
			Yes	No			
Cables	≤Ø 25	Bottom	✓	✓	Multitherm Backing	✓	≤ EI 60
	≤Ø 21	Top	✓	✓	Rockwool	✓	≤ EI 120
Cables bundle	≤Ø 80 (≤Ø 21 p/s)	Bottom	✓	✓	Multitherm Backing	✓	≤ EI 120
		Top	✓	✓	Steenwol	✓	
Ribbed Tube	≤Ø 50 met cables (≤Ø 21 p/s)	Bottom	✓	✓	Multitherm Backing	✓	≤ EI 90 U/U
		Top	✓	✓	Rockwool	✓	≤ EI 120 U/C
Multilayer pipes	≤Ø 40	Bottom	✓	✓	Multitherm Backing	✓	
		Top + Multitherm Bandage	✓	✓	Rockwool	✓	
Multilayer pipes , PE isolation	≤Ø 32	Top	✓	✓	Rockwool	✓	
Copper, cast iron and steel pipes	≤Ø 35	Bottom + Multitherm Bandage	✓	✓	Multitherm Backing	✓	≤ EI 60 U/C
		Top + Multitherm Bandage	✓	✓	Rockwool	✓	≤ EI 120 U/C

MV-150: Solid floor, thickness 150 mm  
Ø [mm] Diameter of the penetration

## 8. Currently tested solutions

All the latest tested solutions with the Multisealant GR can be found in our **Multiselector**. Scan the QR code or press the Multiselector button to get directly to the tested solution for your project.



Our **Multiselector** can also be found in our **Mulcol Fire Protection App**. It can be downloaded from the **App Store** (iOS) or **Google Play Store** (Android).



## 9. Pipe Support Penetrations

Service penetrations must be held in place  $\leq 450$  mm from the fire partition. With floors, the covering must only be applied at the top of the floor at a distance of  $\leq 450$  mm.

## 10. Test Configuration

### Introduction

The test configuration determines the application of plastic pipes. Before testing a pipeline type, the intended use of the pipeline must be considered. Where will it be used in practice? Standard EN 1366-3 sets requirements in this regard. The end of the pipe must be capped or uncapped, based on this. See the test configuration in table 1 and 2.

In a test, the conditions to which the pipeline and the sealing system are exposed to are determined by asking whether one or both pipe ends are capped in practice. The pressure and flowrate of hot gases will be different in a pipe that is in contact with the outside air than in a capped pipe. It is important to ensure that the sealing system is tested under appropriate conditions.

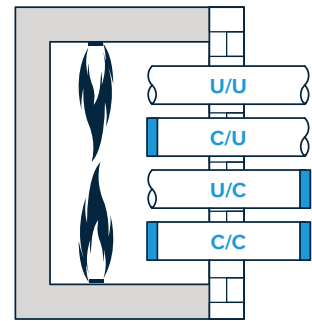

**Table 1 - Test configuration plastic pipes**

Test setup	Pipe end		Permitted use			
	In the oven	Outside the oven	U/U	C/U	U/C	C/C
U/U	Uncapped	Uncapped	✓	✓	✓	✓
C/U	Capped	Uncapped	✗	✓	✓	✓
U/C	Uncapped	Capped	✗	✗	✓	✓
C/C	Capped	Capped	✗	✗	✗	✓

**Table 2 - Test configuration metal pipes**

Test setup	Pipe end		Permitted use		
	In the oven	Outside the oven	U/C	C/U	C/C
U/C *	Uncapped	Capped	✓	✓	✓
C/U	Capped	Uncapped	✗	✓	✓
C/C	Capped	Capped	✗	✗	✓

\* U/C tested and therefore U/U is covered

### Plastic Pipes

Table H.1 shows a few examples of types of pipes and the intended use, where the end of the pipe is capped or uncapped. The table does not take all possible applications into account. The choice of whether to close the end or leave it open depends on a number of aspects: is the system under pressure and it is ventilated or unventilated? Consider the intended use of the pipe to determine whether it should be capped or left uncapped. If national regulations set different requirements than those contained in table H1, follow the regulations.

**Table H.1 - Plastic Pipe Test Configuration per Application**

Type of pipe	Pipe end		Test setup
	In the oven	Outside the oven	
Rainwater drainage	Uncapped	Uncapped	U/U
Sewage, Ventilated	Uncapped	Uncapped	U/U
Sewage, Unventilated	Uncapped	Capped	U/C
Gas pipe, drinking water pipe, hot water pipe	Uncapped	Capped	U/C

*There is no application for a plastic pipe penetration with a test classification of C/U or C/C, according to table H.1 from EN 1366-3.*

**Metal Pipes**

Metal pipes will normally be closed in the furnace as no open end is to be expected in the event of a fire, this due to the melting away of metal. Herewith is assumed that the suspension system remains in place. If the pipes are supported by a non fire resistant suspension system or are waste disposal shafts, the pipes are not sealed in the furnace, as shown in Table H.2.

**Table H.2 - Test Configuration Metal Pipe by Application**

Type of pipe	Construction		Test setup
	In the oven	Outside the oven	
Supported by a fire resistant <sup>a</sup> suspension	Capped	Uncapped	C/U
Supported by a non fire resistant suspension system	Uncapped	Capped	U/C
Shafts for waste disposal	Uncapped	Capped	U/C

<sup>a</sup>confirmed by testing or calculations (e.g. Eurocodes)



## 11. Building Element Properties

### Flexible walls

The minimum wall thickness should be 100 mm and the wall should consist of steel or wooden studs\* with at least 2 layers of cladding on each side with a thickness of 12.5 mm.

### Rigid walls

The minimum wall thickness is 100 mm and the wall must consist of concrete, aerated concrete or brickwork, with a minimum density of 400 kg/m<sup>3</sup> or wood (CLT) with a minimum density of 400 kg/m<sup>3</sup>.

### Rigid floors

The minimum floor thickness is 150 mm and the floor must consist of concrete or aerated concrete, with a minimum density of 400 kg/m<sup>3</sup> or wood (CLT) with a minimum thickness of 140 mm and a density of 400 kg/m<sup>3</sup>.

*\*There must be a minimum distance of 100 mm from each part of the conduit seal to a timber stud and the gap between the conduit seal and the stud must be capped. The cavity between the conduit seal and the stud must have at least 100 mm class A1 or A2 insulation (according to EN 13501-1).*

The support structure must be classified in accordance with EN 13501-2 for the specified fire resistance.

## 12. Available Documents

### Technical documents available

- ✓ Product Data Sheet (PDS)
- ✓ Technical Data Sheet (TDS)
- ✓ Safety Data Sheet (SDS)
- ✓ Installation Manual
- ✓ CE certificate
- ✓ Emission reports
- ✓ Acoustic report

### Approvals

- ✓ Tested in accordance with EN 1366-3
- ✓ Classification in accordance with EN 13501-2
- ✓ Certified in accordance with EAD 350454-00-1104
- ✓ ETA report 23/0055
- ✓ Declaration of Performance (DoP)

The above documents are available from your Mulcol contact or via [www.mulcol.com](http://www.mulcol.com)



For help in finding the right fire-stopping finish for penetrations, see our **Multiselector** at [www.mulcol.com](http://www.mulcol.com) or download the **Mulcol Fire Protection App** in the **App Store** (iOS) or **Google Play Store** (Android).



For the digital registration of firestopping in your buildings, you can use the **Mulcol Data Manager** free of charge. For registration on site, use our **Mulcol Fire Protection App**.



Mulcol International  
The Netherlands

Promenade 75  
5401 GM Uden

T. +31 (0)118 72 61 40  
contact@mulcol.com

[www.mulcol.com](http://www.mulcol.com)



GB