

BEFORE PLACING

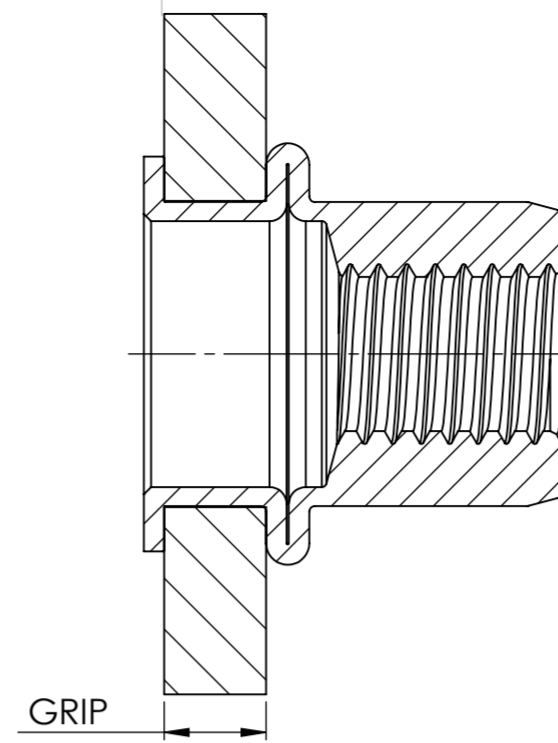

AFTER PLACING

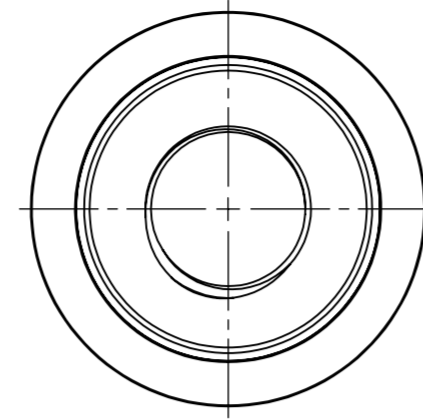
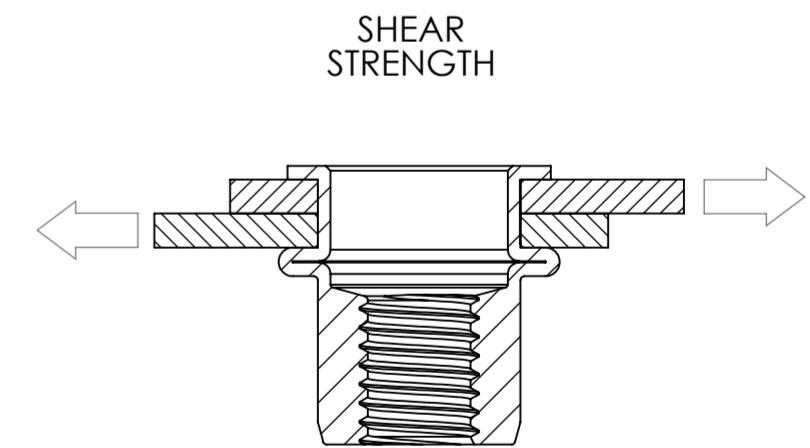
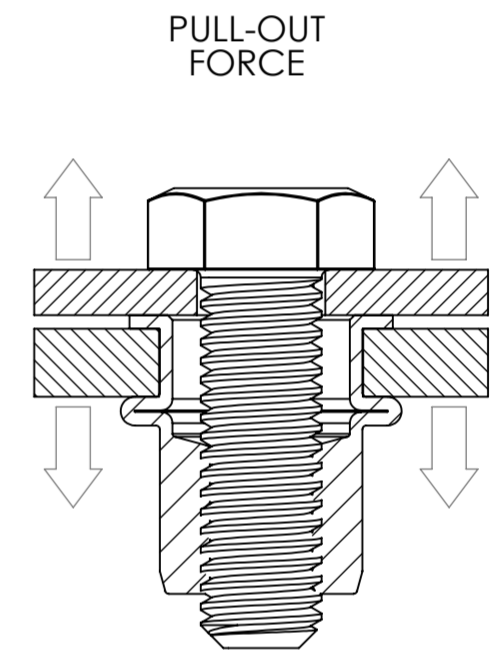
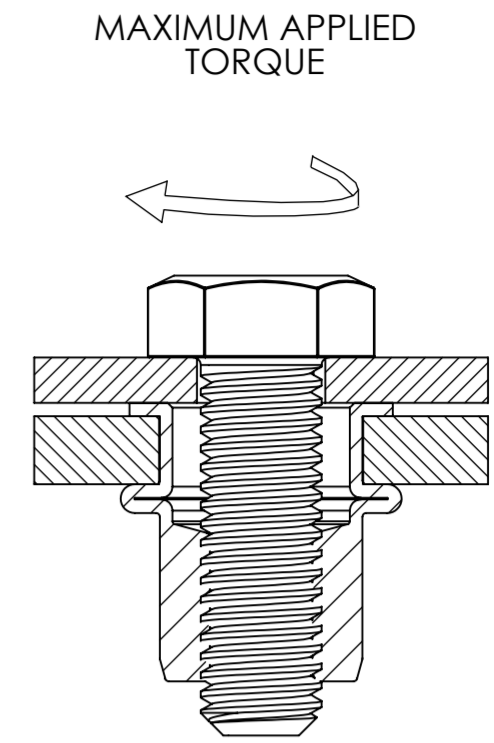
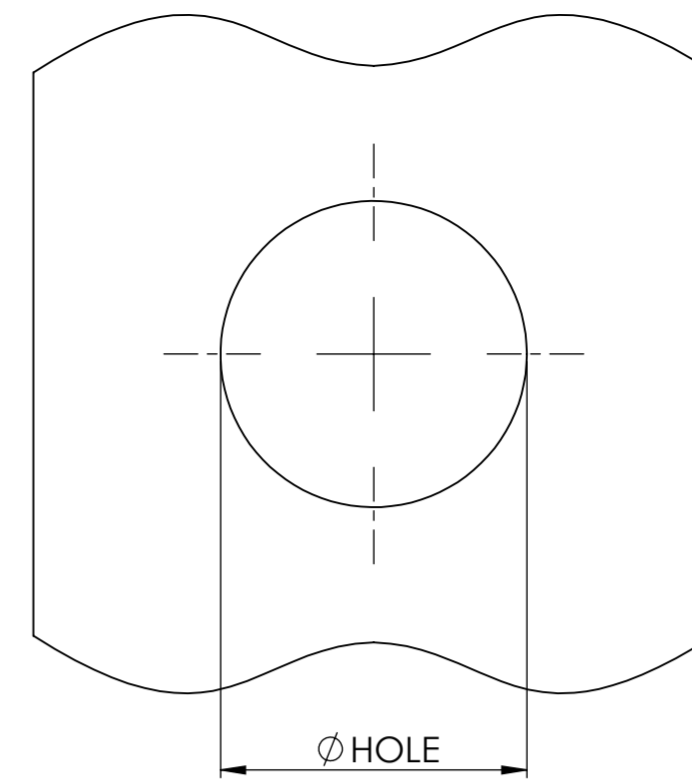

THREAD SIZE	PART NUMBER	GRIP RANGE		Ø HOLE SIZE +0.1 -0.0	DIMENSIONS				PERFORMANCE (NOTE 1)		
		MIN.	MAX.		ØA +0.0 -0.2	ØB +0.0 -0.5	D +0.1 -0.1	M +0.5 -0.0	MAXIMUM APPLIED TORQUE (Nm)	PULL OUT FORCE (kN)	SINGLE SHEAR STRENGTH (kN)
M3	N23 M03 CO1	0.5	2.5	5.0	4.9	7.0	0.8	10.5	1.5	4.9	0.9
	N23 M03 CO2	2.5	3.5					11.5			
M4	N23 M04 CO1	0.5	3.0	6.0	5.9	9.0	1.0	11.0	5.1	6.2	1.6
	N23 M04 CO2	3.0	5.5					14.0			
M5	N23 M05 CO1	0.5	3.0	7.0	6.9	10.0	1.0	13.0	7.9	10.8	2.4
	N23 M05 CO2	3.0	5.5					16.0			
	N23 M05 CO3	5.5	8.0					19.0			
M6	N23 M06 CO1	0.5	3.0	9.0	8.9	12.0	1.5	16.0	12.4	17.6	3.4
	N23 M06 CO2	3.0	5.5					18.5			
	N23 M06 CO3	5.5	8.0					21.0			
M8	N23 M08 CO1	0.5	3.0	11.0	10.9	15.0	1.5	17.5	32.0	24.5	4.4
	N23 M08 CO2	3.0	5.5					20.0			
	N23 M08 CO3	5.5	8.0					22.5			
	N23 M08 CO4	8.0	10.5					25.0			
M10	N23 M10 CO1	0.5	3.0	12.0	11.9	16.0	2.0	19.0	45	29.4	4.9
	N23 M10 CO2	3.0	6.0					24.0			
	N23 M10 CO3	6.0	9.0					27.0			
	N23 M10 CO4	9.0	12.0					30.0			
M12	N23 M12 CO1	1.0	4.0	16.0	15.9	22.0	2.0	25.0	60	48.0	6.8
	N23 M12 CO2	4.0	7.0					28.0			
	N23 M12 CO3	7.0	10.0					31.0			

NOTES

- PULL OUT FORCE AND SHEAR STRENGTH VALUES ARE AS TESTED IN MAXIMUM GRIP AND ARE TYPICAL VALUES IN STEEL PLATE.
- MASTERGRIP IS A TRADE MARK OF STANLEY BLACK & DECKER, INC. AND ITS AFFILIATES.

PART DESCRIPTION	MASTERGRIP OPEN END RIVET NUTS LARGE FLANGE HEAD	PART NUMBER	SEE TABLE
DIMENSIONS IN mm UNLESS STATED		This document is the property of Avdel UK Limited and is issued on the express terms that it is to be treated as private and confidential and is not to be communicated to any other person. All patents, manufacturing rights, design rights and copyright are reserved by Avdel UK Limited.	
MATERIAL	LOW CARBON STEEL		
HEAT TREATMENT	ANNEALED		
SURFACE TREATMENT	ZINC PLATE & CLEAR Cr3 PASSIVATE	LUBRICATION	NONE
DRAWN	DATE	ISSUE	A B B2 - - -
LEL	23/6/2020	C.N.	20-154 23-039 24-086 - - -
DRAWING DESCRIPTION	MASTERGRIP™ OPEN END SPLINED RIVET NUTS STEEL		
STANLEY Engineered Fastening		WEIGHT	- DO NOT SCALE
STANLEY Engineered Fastening 43 Hardwick Grange, Woolston, Warrington, England, WA1 4RF Registered in England: No. 315076		DRAWING NUMBER	N23-CO S
			Size: A2 Scale: 2:1 Sheet: 1 OF 1 Revision: B2