

更改日期	2020/06/17	设置内容	修改
REV		MODIFICATION	DRAWN

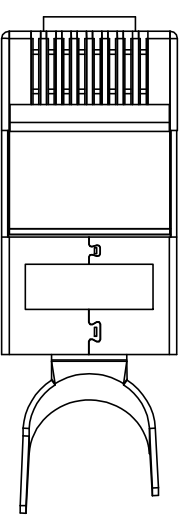

- SPECIFICATIONS**
- 1. ELECTRICAL:**  
 UL APPLICATIONS: 250 VOLTS AC MAX. AT 2 AMPS.  
 DIELECTRIC WITHSTANDING VOLTAGE: 1000 VOLTS AC. 60 SEC.  
 INSULATION RESISTANCE: 500 MO.  
 CONTACT RESISTANCE: 20mΩ MAX.  
 OPERATING AMBIENT TEMPERATURE: -40°C - 70°C.
- 2. MECHANICAL:**  
 STRAIN RELIEF: 20° ROUND MIN.  
 DURABILITY: 1200 MATING CYCLES.
- 3. MATERIAL:**  
 HOUSING: POLYCARBONATE, UL94V-0 OR UL94V-2.  
 COLOR: TRANSPARENT OR OTHER COLOR ARE AVAILABLE.  
 CONTACT BLADE: COPPER ALLOY.  
 GOLD PLATING: 30"-500" ARE AVAILABLE.  
 SHIELDED SHELL: COPPER NICKEL ALLOY.
- 4. USAGE:**  
 SUITABLE FOR STRANDED & SOLID WIRE 23AWG ~ 26AWG.  
 (It can be used for the wire OD from 0.135 ~ 0.145)
- 规范**
- 1. 电器特性:**  
 UL应用: 250 VOLTS AC. 最大 2 AMPS  
 耐电压: 1000 VOLTS AC. 60秒  
 绝缘阻抗: 500 百万欧姆  
 接触阻抗: 小于 20 毫欧姆  
 工作环境温度: -40°C ~ 70°C.
- 2. 机械特性:**  
 拉力测试: 大于 20磅.  
 插拔测试: 大于 1200 次.
- 3. 材质:**  
 塑胶体: 聚碳酸酯, UL-94V-0 或 UL94V-2.  
 颜色: 透明, 或依客户需求  
 金片: 铜合金.  
 镀金厚度: 30"-500", 皆可提供.  
 铜外壳: 铜镍合金.
- 4. 适用线材:**  
 多股线 & 单股线, 23AWG ~ 26AWG均适用.  
 (芯线直径: 0.135 ~ 0.145 均可适用)

客户用产品图

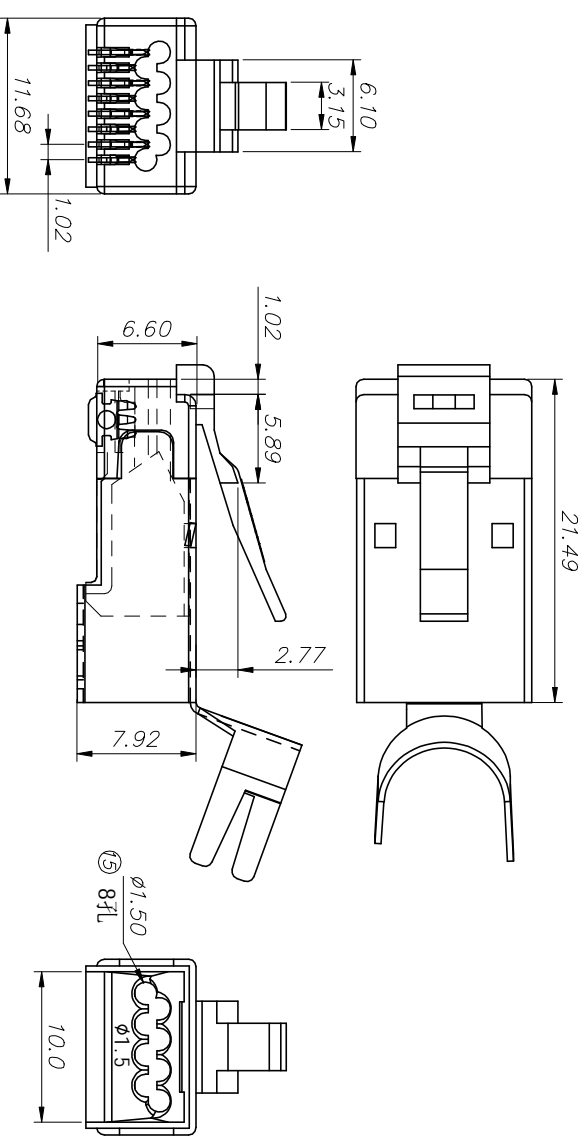

BLADE:	E	EB	Y	YB	Z	A	AE	AB	ZD
Drawing									
Mark					✓				✓
GOLD PLATING	3Mu	3u	6u	15u	30u	50u			
Mark						✓		Mark	
								CABLE TYPE	ROUND
								Mark	FLAT



宁波卓新通讯连接器有限公司  
 NINGBO EXCELLENCE COMMUNICATED CONNECTOR CO.,LTD

DIMENSION IN mm (Inch)	材质	图号	
TOLERANCE UNLESS OTHERWISE SPECIFIED	MATERIAL	DWG NO.	
.X±0.20	PC	PLUG-513-0005	
.XX±0.10			
.X±5°	名称	P88R5J2D50W2S1 T-3Y(线孔1.5通孔, 配厚3.3支架, 镀亮大线槽通孔, 2468#埋超短片)	
.XX±2°	TITLE		
审核	核对	制图	比例
沈红波	钟均江	Cathlyli	2/1
Approval	Checked	DRAWN	张数
			1/1
		角法	更改
		PROJ.	REV
			A

更改 REV	出图日期 DATE	设计内容 MODIFICATION	修改 DRAWN
	2019/09/06		

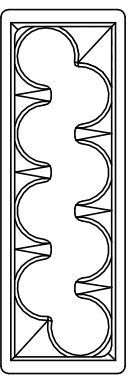
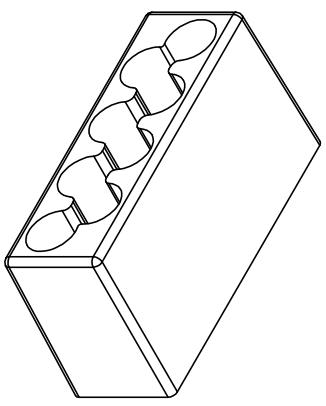
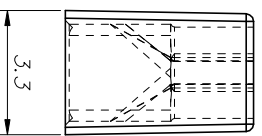
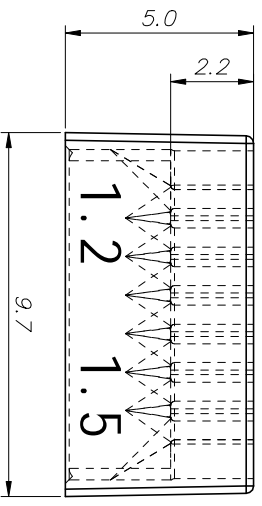
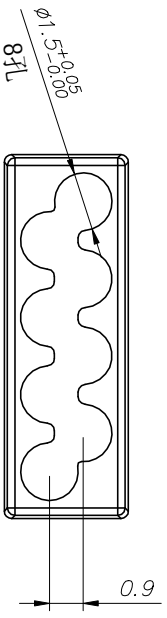

客户用产品图

<b>EXW</b> 宁波卓新通讯连接器有限公司 NINGBO EXCELLENCE COMMUNICATED CONNECTOR CO.,LTD		材 质 MATERIAL	图 号 DWG NO.
DIMENSION IN mm (Inch) TOLERANCE UNLESS OTHERWISE SPECIFIED		PC	PLUG INSERT-040D
X±0.20	X°±5°	名称 TITLE	3Y双排支架(线孔1.5)厚3.3
.XX±0.10	.XX°±2°	制 图 DRAWN	Zoach
审 核 APPROVAL	核 对 CHECKED	比 例 SCALE	5/1
<b>沈红波</b>	<b>钟均江</b>	角 法 PROJ	
		张 数 SHEET	1/1
		更 改 REV	A