



®

Dongguan Anci Electronic Technology Co., Ltd.

Add.: 1-2 Floor, Building A, No.11, Headquarters 2 Road, Songshan Lake
Hi-tech Industrial Development Zone, Dongguan City, Guangdong Pr., China.

Tel: 86 -769 -8507 5888 Fax: 86 -769 -8507 5898 Web: www.anci.com

CERTIFICATE OF CONFORMITY

Certificate No.: 20AE06181E 001

This Certification of Compliance is hereby issued to the product designated below

Report No. : EA2006181E 01001

Applicant : Ledlenser Corporation Ltd.

Address : No.25, Yudong 1 Road, Dongcheng Town, Yangdong District,
Yangjiang City, GD, 529931, China

Manufacturer : Ledlenser Corporation Ltd.

Address : No.25, Yudong 1 Road, Dongcheng Town, Yangdong District,
Yangjiang City, GD, 529931, China

Description of Product : 3xAAA 1xXP LED SL6 Flashlight

Model No. : SL6

Input Rating : AAA LR03 1.5V*3

Test Standards : EN IEC 55015:2019
EN 61547:2009

This certificate of conformity is based on evaluation of a sample of the above mentioned product. Technical report and documentation are at the license Holder's disposal. This is to certify that the tested sample is in conformity with the Council Directive 2014/30/EU, referred to as the EMC. It is possible to use CE marking to demonstrate the conformity with this EMC Directive.



Test Laboratory

Alan He
Director
Date of Issue: July 9, 2020

This certificate of conformity is based on a single evaluation of the submitted sample(s) of the above mentioned product. It does not imply an assessment of the whole production and other relevant Directives have to be observed.



EMC TEST REPORT



For Electromagnetic Interference of

Report Reference No. :	EA2006181E 01001	
Engineer (name + signature)	Wite Chen	
Reviewed by (name + signature)	Tiger Xu	
Approved by (name + signature)	Alan He	
Date of Receipt of EUT	June 23, 2020	
Date of Test	June 23, 2020 to July 9, 2020	
Date of issue	July 9, 2020	
Testing Laboratory	Dong Guan Anci Electronic Technology Co., Ltd	
Address	1-2 Floor, Building A, No.11, Headquarters 2 Road, Songshan Lake Hi-tech Industrial Development Zone, Dongguan City, Guangdong Pr., China.	
Laboratory location	EMC Laboratory	
Applicant's name	Ledlenser Corporation Ltd.	
Address	No.25, Yudong 1 Road, Dongcheng Town, Yangdong District, Yangjiang City, GD, 529931, China	
Manufacturer	Ledlenser Corporation Ltd.	
Address	No.25, Yudong 1 Road, Dongcheng Town, Yangdong District, Yangjiang City, GD, 529931, China	
First Factory's name	Ledlenser Corporation Ltd.	
Address	No.25, Yudong 1 Road, Dongcheng Town, Yangdong District, Yangjiang City, GD, 529931, China	

Test specification:

EUT description	3xAAA 1xXP LED SL6 Flashlight
Trade Mark.....	 LEDLENSER
Model/Type reference	SL6
Test Sample.....	SL6
Input Ratings.....	AAA LR03 1.5V*3
Standards.....	EN IEC 55015:2019 EN 61547:2009

The device described above was tested by Dong Guan Anci Electronic Technology Co., Ltd. to determine the maximum emission levels emanated from the device and severity levels of the device endure and its performance criterion. The measurement results are contained in this test report and Dong Guan Anci Electronic Technology Co., Ltd. assumes full responsibility for the accuracy and completeness of these measurements. This report shows the EUT is technically compliance with the above official standards.

This report applies to the above sample only and shall not be reproduced in part without written approval of Dong Guan Anci Electronic Technology Co., Ltd.

Table of Contents	Page
1 . GENERAL INFORMATION	6
1.1 PRODUCT INFORMATION	6
1.2 Details about the Test Laboratory	7
2 . SUMMARY OF TEST RESULTS	9
2.1 MEASUREMENT UNCERTAINTY	10
2.2 DESCRIPTION OF TEST MODES	10
2.3 BLOCK DIGRAM SHOWING THE CONFIGURATION OF SYSTEM TESTED	11
3 . EMISSION TEST	12
3.1 Conducted Disturbance at Mains Terminals	12
3.1.1 LIMIT OF CONDUCTED EMISSION(MAINS PORT)	12
3.1.2 MEASUREMENT INSTRUMENTS LIST	12
3.1.3 TEST PROCEDURE	13
3.1.4 DEVIATION FROM TEST STANDARD	13
3.1.5 TEST SETUP	13
3.1.6 EUT OPERATING CONDITIONS	13
3.1.7 TEST RESULTS	14
3.2.1 Specification Limits	15
3.2.2 MEASUREMENT INSTRUMENTS LIST	15
3.2.3 TEST PROCEDURE	15
3.2.4 TEST SETUP	16
3.2.5 EUT OPERATING CONDITIONS	16
3.2.6 TEST RESULTS	16
3.3 Radiated Disturbance (30MHz to 1000MHz)	17
3.3.1 LIMITS OF RADIATED EMISSION MEASUREMENT	17
3.3.2 MEASUREMENT INSTRUMENTS LIST	17
3.3.3 TEST PROCEDURE	18
3.3.4 DEVIATION FROM TEST STANDARD	18
3.3.5 TEST SETUP	19
3.3.6 EUT OPERATING CONDITIONS	19
3.3.7 TEST RESULTS	20
3.4.1 MEASUREMENT INSTRUMENTS LIST	23
3.4.2 LIMITS OF MAGNETIC EMISSION MEASUREMENT	23
3.4.3 LARGE LOOP ANTENNA SETUP DIAGRAM	24
3.4.4 OPERATING CONDITIONS OF THE EUT	25
3.4.5 MAGNETIC EMISSION DATA	25
3.4.6 TEST RESULTS	26
3.5.1 LIMITS OF HARMONICS CURRENT MEASUREMENT	30
3.5.2 MEASUREMENT INSTRUMENTS LIST	31
3.5.3 TEST PROCEDURE	31
3.5.4 DEVIATION FROM TEST STANDARD	31

Table of Contents	Page
3.5.5 TEST SETUP	31
3.5.6 EUT OPERATING CONDITIONS	31
3.6 VOLTAGE FLUCTUATION AND FLICKS MEASUREMENT	33
3.6.1 LIMITS OF VOLTAGE FLUCTUATION AND FLICKS MEASUREMENT	33
3.6.2 MEASUREMENT INSTRUMENTS LIST	33
3.6.3 TEST PROCEDURE	33
3.6.4 DEVIATION FROM TEST STANDARD	33
3.6.5 TEST SETUP	34
4 . EMC IMMUNITY TEST	35
4.1 STANDARD COMPLIANCE/SERVRITY LEVEL/CRITERIA	35
4.2 GENERAL PERFORMANCE CRITERIA	36
4.3 GENERAL PERFORMANCE CRITERIA TEST SETUP	36
4.4 ESD TESTING	37
4.4.1 TEST SPECIFICATION	37
4.4.2 MEASUREMENT INSTRUMENTS	37
4.4.3 TEST PROCEDURE	37
4.4.4 DEVIATION FROM TEST STANDARD	37
4.4.5 TEST SETUP	38
4.4.6 TEST RESULTS	39
4.5 RS TESTING	40
4.5.1 TEST SPECIFICATION	40
4.5.2 MEASUREMENT INSTRUMENTS	40
4.5.3 TEST PROCEDURE	40
4.5.4 DEVIATION FROM TEST STANDARD	40
4.5.5 TEST SETUP	41
4.5.6 TEST RESULTS	42
4.6 EFT/BURST TESTING	43
4.6.1 TEST SPECIFICATION	43
4.6.2 MEASUREMENT INSTRUMENTS	43
4.6.3 TEST PROCEDURE	43
4.6.4 DEVIATION FROM TEST STANDARD	43
4.6.5 TEST SETUP	44
4.6.6 TEST RESULTS	45
4.7 SURGE TESTING	46
4.7.1 TEST SPECIFICATION	46
4.7.2 MEASUREMENT INSTRUMENTS	46
4.7.3 TEST PROCEDURE	46
4.7.4 DEVIATION FROM TEST STANDARD	47
4.7.5 TEST SETUP	47
4.7.6 TEST RESULTS	48
4.8 INJECTION CURRENT TESTING	49

Table of Contents	Page
4.8.1 TEST SPECIFICATION	49
4.8.2 MEASUREMENT INSTRUMENTS	49
4.8.3 TEST PROCEDURE	49
4.8.4 DEVIATION FROM TEST STANDARD	49
4.8.5 TEST SETUP	50
4.8.6 TEST RESULTS	51
4.9 VOLTAGE INTERRUPTION/DIPS TESTING	52
4.9.1 TEST SPECIFICATION	52
4.9.2 MEASUREMENT INSTRUMENTS	52
4.9.3 TEST PROCEDURE	52
4.9.4 DEVIATION FROM TEST STANDARD	52
4.9.5 TEST SETUP	53
4.9.6 TEST RESULTS	53
4.10 POWER-FREQUENCY MAGNETIC FIELDS	54
4.10.1 MEASUREMENT INSTRUMENTS	54
4.10.2 TEST LEVEL AND PERFORMANCE CRITERION	54
4.10.3 TEST PROCEDURE	54
4.10.4 DEVIATION FROM TEST STANDARD	54
4.10.5 TEST SETUP	55
4.10.6 TEST RESULTS	55
5. ATTACHMENT	56
5.1 EUT Test Photo	56
5.2 EUT Photo	58

1. GENERAL INFORMATION

1.1 PRODUCT INFORMATION

1. The equipment is 3xAAA 1xXP LED SL6 Flashlight Luminaires for the use in lighting equipment.
2. The model of this application is only different in shape and appearance, and the others are all the same structure. Does not involve differences in electrical parameters.
3. This test report only reflects the worst data of the test mode.

All tests was performed on model SL6.

The EUT passed the test.

1.2 Details about the Test Laboratory

Test Site 1 (CNAS number L6214):

Company name: Dongguan Anci Electronic Technology Co., Ltd.

Address: 1-2 Floor, Building A, No.11, Headquarters 2 Road, Songshan Lake
Hi-tech Industrial Development Zone, Dongguan City,
Guangdong Pr., China.

Telephone: +86-769- 8507 5888

Fax: +86-769- 8507 5898

Test Site 2 (Subcontract test: CNAS number L0468):

Company name: Guangdong Dongguan Quality Supervision Testing Center

Address: No.2 South Industry Road, Dongguan Songshan Lake
Sci.&Tech. Industrial Park, Guangdong Province, China

Telephone: +86 769 2307 1111

Fax: +86 769 2307 7221

Standard	Test Item	Test Site
EN IEC 55015:2019	Conducted Disturbance at the electric power supply interface	N/A
	Conducted Disturbance at wired network interfaces other than powersupply	N/A
	Conducted Disturbance at local wired ports other than electrical power supply interface	N/A
	Radiated Disturbance (30MHz to 1GHz)	1
	Magnetic Disturbance (9KHz to 30MHz)	1
EN IEC 61000-3-2:2019	Harmonic Current Emission	N/A
EN 61000-3-3:2013+A1:2019	Voltage Fluctuations & Flicker	N/A
EN 61000-4-2:2009	Electrostatic Discharge	1
EN 61000-4-3:2006 +A1:2008+A2: 2010	RF electromagnetic field	2
EN 61000-4-4:2012	Fast transients	N/A
EN 61000-4-5:2014	Surges	N/A
EN 61000-4-6:2014	Injected Current	N/A
EN 61000-4-8:2010	Power Frequency Magnetic Field	2
EN 61000-4-11:2004	Volt. Interruptions Volt. Dips	N/A

2. SUMMARY OF TEST RESULTS

Test procedures according to the technical standards:

Emission				
Standard	Test Item	Clause	Judgment	Remark
EN IEC 55015:2019	Conducted Disturbance at the electric power supply interface	4.3.1	N/A	
	Conducted Disturbance at wired network interfaces other than powersupply	4.3.2	N/A	
	Conducted Disturbance at local wired ports other than electrical power supply interface	4.4	N/A	
	Radiated Disturbance (30MHz to 1GHz)	4.5.3	PASS	
	Magnetic Disturbance (9KHz to 30MHz)	4.5.2	PASS	
EN IEC 61000-3-2:2019	Harmonic Current Emission	7	N/A	
EN 61000-3-3:2013+A1:2019	Voltage Fluctuations & Flicker	5	N/A	
Immunity (EN61547:2009)				
Section	Test Item	Clause	Judgment	Performance Criteria
EN 61000-4-2:2009	Electrostatic Discharge	5.2	PASS	B
EN 61000-4-3:2006 +A1:2008+A1:2010	RF electromagnetic field	5.3	PASS	A
EN 61000-4-4:2012	Fast transients	5.4	N/A	B
EN 61000-4-5:2014	Surges	5.5	N/A	B
EN 61000-4-6:2014	Injected Current	5.6	N/A	A
EN 61000-4-8:2010	Power Frequency Magnetic Field	5.7	PASS	A
EN 61000-4-11:2004	Volt. Interruptions Volt. Dips	5.8	N/A	C / B

NOTE:

(1) "N/A" denotes test is not applicable in this Test Report

2.1 MEASUREMENT UNCERTAINTY

The reported uncertainty of measurement $y \pm U$ where expanded uncertainty U is based on a standard uncertainty multiplied by a coverage factor of $k=2$ providing a level of confidence of approximately 95 %.

A. Conducted Measurement :

Test Site	Method	Measurement Frequency Range	U · (dB)	NOTE
Test Site 1	ANSI	9 KHz ~ 30MHz	3.19	

B. Conducted Disturbance at Control Terminals :

Test Site	Method	Measurement Frequency Range	U · (dB)	NOTE
Test Site 2	ANSI	9 KHz ~ 30MHz	3.19	

C. Magnetic Disturbance (9KHz to 30MHz) t :

Test Site	Method	Measurement Frequency Range	U · (dB)	NOTE
Test Site 1	ANSI	9KHz ~ 30MHz	2.54	

D. Radiated Disturbance (30MHz to 1GHz) :

Test Site	Method	Measurement Frequency Range	Ant. H / V	U · (dB)	NOTE
Test Site 1	ANSI	30MHz ~ 200MHz	V	3.69	
		30MHz ~ 200MHz	H	3.69	
		200MHz ~ 1,000MHz	V	3.67	
		200MHz ~ 1,000MHz	H	3.67	

2.2 DESCRIPTION OF TEST MODES

To investigate the maximum EMI emission characteristics generates from EUT, the test system was pre-scanning tested base on the consideration of following EUT operation mode or test configuration mode which possible have effect on EMI emission level. Each of these EUT operation mode(s) or test configuration mode(s) mentioned above was evaluated respectively.

Pre-scan mode	
Mode 1	Normal Operation

Final-scan mode	
Mode 1	Normal Operation

2.3 BLOCK DIGRAM SHOWING THE CONFIGURATION OF SYSTEM TESTED

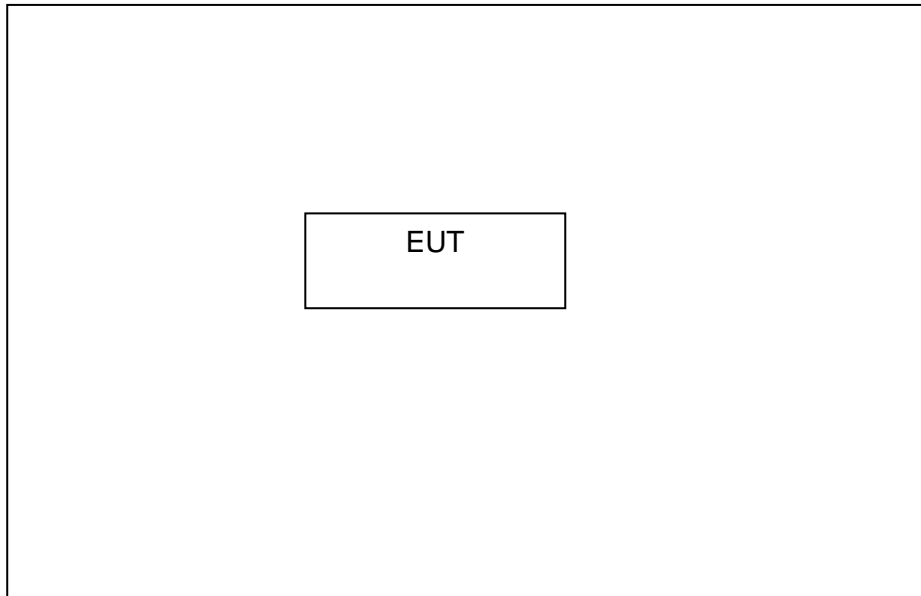

The EUT has been tested as an independent unit together with other necessary accessories or support units. The following support units or accessories were used to form a representative test configuration during the tests.

Item	Equipment	Specification
E-1	N/A	N/A

Item	Type of cable
C-1	N/A

3. EMISSION TEST

3.1 Conducted Disturbance at Mains Terminals

3.1.1 LIMIT OF CONDUCTED EMISSION(MAINS PORT) (Frequency Range 9KHz-30MHz)

FREQUENCY (MHz)	(dBuV)	
	Quasi-peak	Average
0.009-0.05	110	--
0.05-0.15	90-80	--
0.15 -0.5	66 - 56 *	56 - 46 *
0.50 -5.0	56.00	46.00
5.0 -30.0	60.00	50.00

Note:

- (1) The tighter limit applies at the band edges.
- (2) The limit of " * " marked band means the limitation decreases linearly with the logarithm of the frequency in the range.
- (3) The test result calculated as following:

Measurement Value = Reading Level + Correct Factor

Correct Factor = Insertion Loss + Cable Loss + Attenuator Factor (if use)

Margin Level = Measurement Value - Limit Value

The following table is the setting of the receiver

Receiver Parameters	Setting
Attenuation	10 dB
Start Frequency	0.009 MHz
Stop Frequency	30 MHz
IF Bandwidth	200Hz (from 9kHz to 150kHz) and 9kHz (from 150kHz to 30MHz).

3.1.2 MEASUREMENT INSTRUMENTS LIST

Item	Instr.Code	Kind of Equipment	Manufacturer	Type No.	Serial No.	Calibrated until
1	AN-E024	EMI Test Receiver	ROHDE&SCHWARZ	ESPI	101144	2020-11-28
2	AN-E025	LISN	ROHDE&SCHWARZ	ENV216	101413	2020-11-28
3	AN-E029	RF Cable	N/A	ZT06S-NJ-NJ-2.5M	19044022	2021-05-23
5	AN-E044	2# Shielded Room	chengyu	8m*4m*3m	N/A	2022-06-18
6	AN-E046	Test Software	Farad	EZ-EMC Ver:ANCI-8A1	N/A	N/A

Remark: " N/A" denotes No Model No. , Serial No. or No Calibration specified.

3.1.3 TEST PROCEDURE

- a. The EUT was placed 0.4 meters from the horizontal ground plane with EUT being connected to the power mains through a line impedance stabilization network (LISN). All other support equipments powered from additional LISN(s). The LISN provide 50 Ohm/ 50uH of coupling impedance for the measuring instrument.
- b. Interconnecting cables that hang closer than 40 cm to the ground plane shall be folded back and forth in the center forming a bundle 30 to 40 cm long.
- c. I/O cables that are not connected to a peripheral shall be bundled in the center. The end of the cable may be terminated, if required, using the correct terminating impedance. The overall length shall not exceed 1 m.
- d. LISN at least 80 cm from nearest part of EUT chassis.
- e. For the actual test configuration, please refer to the related Item –EUT Test Photos.

3.1.4 DEVIATION FROM TEST STANDARD

No deviation

3.1.5 TEST SETUP

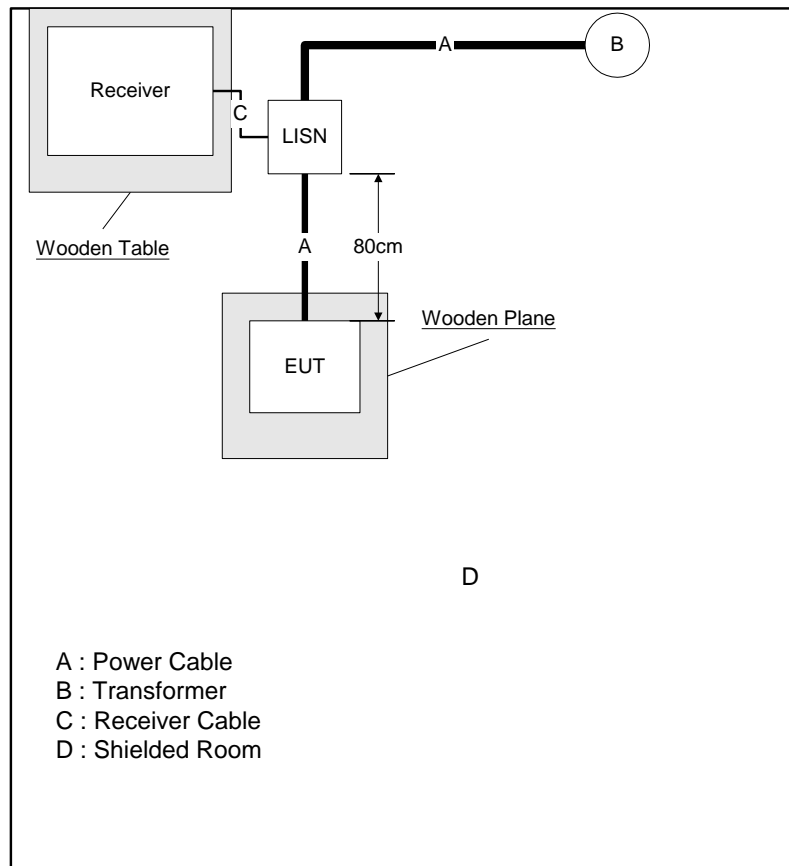

3.1.6 EUT OPERATING CONDITIONS

The EUT exercise program used during radiated and/or conducted emission measurement was designed to exercise the various system components in a manner similar to a typical use.

3.1.7 TEST RESULTS

EUT:	/	Model No.:	/
Temperature:	/	Relative Humidity:	/
Pressure:	/	Test Power :	/
Test Mode :	/		

Remark:

- (1) Reading in which marked as QP means measurements by using Quasi-Peak Detector ,and AV means measurements by using Average Detector.
- (2) All readings are QP Mode value unless otherwise stated AVG in column of 『Note』 . If the QP Mode Measured value compliance with the QP Limits and lower than AVG Limits, the EUT shall be deemed to meet both QP & AVG Limits and then only QP Mode was measured, but AVG Mode didn't perform. In this case, a “ * ” marked in AVG Mode column of Interference Voltage Measured.
- (3) Measuring frequency range from 9KHz to 30MHz.
- (4) This test is not applicable for DC input products.

3.2 Conducted Disturbance at Control Terminals

3.2.1 Specification Limits

Disturbance voltage limits at the Control terminals		
Frequency range	Limits dB(μ V)	
	Quasi-peak	Average
0.15MHz to 0.50MHz	84 to 74	74 to 64
0.50MHz to 30MHz	74	64

Notes:

- (1) The limit for radiated test was performed according to as following: CISPR 15.
- (2) The tighter limit applies at the band edges.

3.2.2 MEASUREMENT INSTRUMENTS LIST

Equipment	Manufacturer	Model No.	Serial No.	Next Cal.
Test Receiver	Rohde & Schwarz	ESCI	100227	Oct. 17, 2020
L.I.S.N.	SCHWARZBECK	NSLK8126	8126415	Oct. 17, 2020
ISN	Rohde & Schwarz	ENY81-CA6	101564	Oct. 17, 2020
L.I.S.N.	Rohde & Schwarz	ENV4200	100462	Jun.04,2021
Test Receiver	Rohde & Schwarz	ESR3	102520	May.07,2021

3.2.3 TEST PROCEDURE

- A. The EUT was placed on a non-conductive table 0.8 m above a reference ground plane.
- B. The EUT was placed on a non-conductive support 0.1 m above a reference ground plane.
- C. All power was connected to the EUT through an Artificial Mains Network (AMN).
- D. Conducted common mode disturbance voltage measurements on signal ports were made at the output of the Impedance Stabilization Network (ISN) in accordance with Annex C 4.1.6.2. The ISN was placed 0.8m from the boundary of the EUT and bonded to a reference ground plane.
- E. Conducted common mode disturbance current measurements on signal ports were made with a current probe and externally fitted 150 Ω resistor in accordance with Annex C 4.1.6.3.
- F. Conducted common mode disturbance current measurements on signal ports were made with using a combination of a current probe and capacitive voltage probe in accordance with Annex C 4.1.6.4.

3.2.4 TEST SETUP

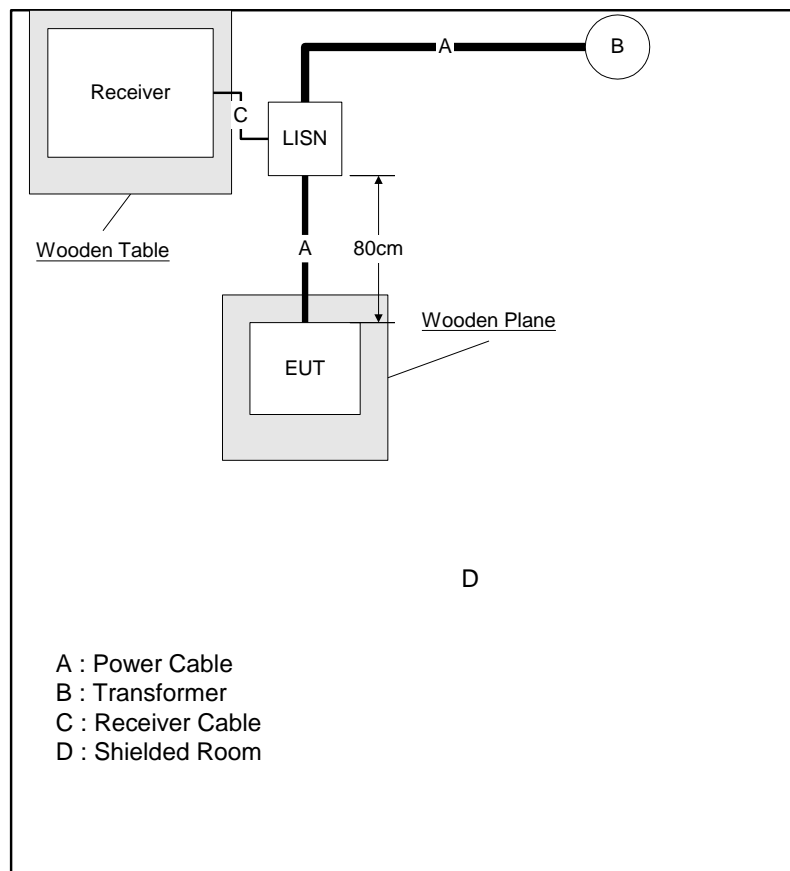

3.2.5 EUT OPERATING CONDITIONS

The EUT exercise program used during radiated and/or conducted emission measurement was designed to exercise the various system components in a manner similar to a typical use.

3.2.6 TEST RESULTS

EUT:	/	Model No.:	/
Temperature:	/	Relative Humidity:	/
Pressure:	/	Test Power :	/
Test Mode :	/		

Note:

1. This test is arranged according to the placement requirements of 3.2.4.
2. Test data see next page
3. This test is not applicable for products without dimming.
4. When the control line and load line are less than 3 meters, this test is not applicable.

3.3 Radiated Disturbance (30MHz to 1000MHz)

3.3.1 LIMITS OF RADIATED EMISSION MEASUREMENT (Below 1000MHz)

FREQUENCY (MHz)	LIMIT (at 3m)
	dBuV/m
30 – 230	40
230 – 1000	47

Notes:

- 1) The limit for radiated test was performed according to as following: CISPR 15.
- 2) The tighter limit applies at the band edges
- 3) Emission level (dBuV/m)=20log Emission level (uV/m).
- 4) Calculation formula: Level=Reading+Factor
Margin=Level-Limit.

3.3.2 MEASUREMENT INSTRUMENTS LIST

3m Radiated Emission Measurement 30MHz-1GHz

Item	Instr.Code	Kind of Equipment	Manufacturer	Type No.	Serial No.	Calibrated until
1	AN-E060	EMI Test Receiver	Rohde & Schwarz	ESCI	100302	2021-05-23
2	AN-E061	Pre-Amplifier	Anritsu	MH648A	M57886	2021-05-23
3	AN-E076	Bilog Antenna	Schwarzbeck	VULB9163	VULB9163-1290	2020-11-15
4	AN-E063	RF Cable	N/A	ZT06S-NJ-NJ-11M	19060398	2021-05-23
5	AN-E064	RF Cable	N/A	ZT06S-NJ-NJ-0.5M	19060400	2021-05-23
6	AN-E065	RF Cable	N/A	ZT06S-NJ-NJ-2.5M	19060404	2021-05-23
7	AN-E056	3m Semi-anechoic Chamber	chengyu	9m*6m*6m	N/A	2022-05-19
8	AN-E069	Test Software	Farad	EZ-EMC Ver:ANCI-2A1	N/A	N/A

3m Radiated Emission Measurement 1GHz-18GHz

Item	Instr.Code	Kind of Equipment	Manufacturer	Type No.	Serial No.	Calibrated until
1	AN-E037	Spectrum Analyzer	Rohde & Schwarz	FSV40	102257	2020-11-28
2	AN-E015	Low noise Amplifiers	A-INFO	LA1018N4009	J1013130524001	2021-05-23
3	AN-E014	Horn antenna	A-INFO	LB-10180-SF	J2031090612123	2021-05-23
4	AN-E018	RF Cable	N/A	N/A	1-2#	2021-05-23
5	AN-E004	RF Cable	N/A	N/A	7#	2021-05-23
6	AN-E043	3m Semi-anechoic Chamber	chengyu	9m*6m*6m	N/A	2022-05-19
7	AN-E045	Test Software	Farad	EZ-EMC Ver:ANCI-3A1	N/A	N/A

Remark: " N/A" denotes No Model No. / Serial No. and No Calibration specified.

3.3.3 TEST PROCEDURE

- a. The measuring distance of at 3 m shall be used for measurements at frequency up to 1GHz. For frequencies above 1GHz, any suitable measuring distance may be used.
- b. The EUT was placed on the top of a rotating table 0.8 meters above the ground at a 3m or 10 meter open area test site. The table was rotated 360 degrees to determine the position of the highest radiation.
- c. The height of the equipment or of the substitution antenna shall be 0.8 m; the height of the test antenna shall vary between 1 m to 4 m. Both horizontal and vertical polarizations of the antenna are set to make the measurement.
- d. The initial step in collecting conducted emission data is a spectrum analyzer peak detector mode pre-scanning the measurement frequency range. Significant peaks are then marked and then Quasi Peak detector mode re-measured.
- e. If the Peak Mode measured value compliance with and lower than Quasi Peak Mode Limit, the EUT shall be deemed to meet QP Limits and then no additional QP Mode measurement performed.
- f. For the actual test configuration, please refer to the related Item –EUT Test Photos.

3.3.4 DEVIATION FROM TEST STANDARD

No deviation

3.3.5 TEST SETUP

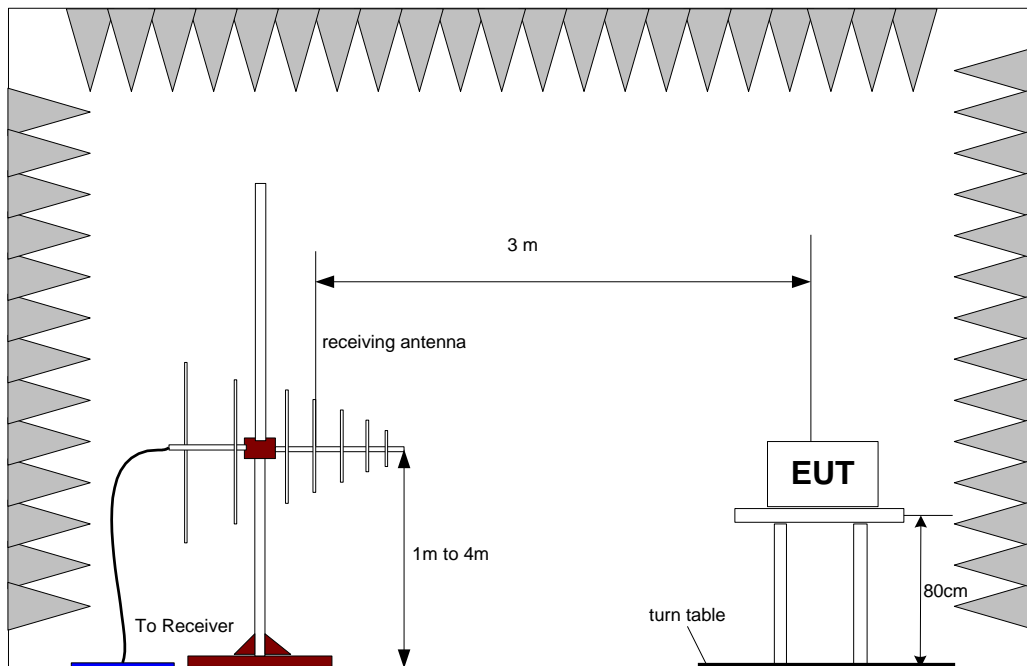

3.3.6 EUT OPERATING CONDITIONS

The EUT tested system was configured as the statements of 3.1.6 Unless otherwise a special operating condition is specified in the follows during the testing.

3.3.7 TEST RESULTS

EUT:	3xAAA 1xXP LED SL6 Flashlight	Model No.:	SL6
Temperature:	23°C	Relative Humidity:	57%
Pressure:	1008 hPa	Test Power :	DC 4.5V
Test Mode :	Normal Operation		

Remark:

- (1) Reading in which marked as QP or Peak means measurements by using are Quasi-Peak Detector or Peak Detector.
- (2) All readings are Peak unless otherwise stated QP in column of 『Note』 . Peak denotes that the Peak reading compliance with the QP Limits and then QP Mode measurement didn't perform.
- (3) Measuring frequency range from 30MHz to 1GHz.
- (4) If the peak scan value lower limit more than 20dB, then this signal data does not show in table.

M/N: SL6
 Op Cond.: Normal Operation
 Comment: DC 4.5V
 Test Spec: Horizontal
 Note: Max Lighting

Detailed results are shown below

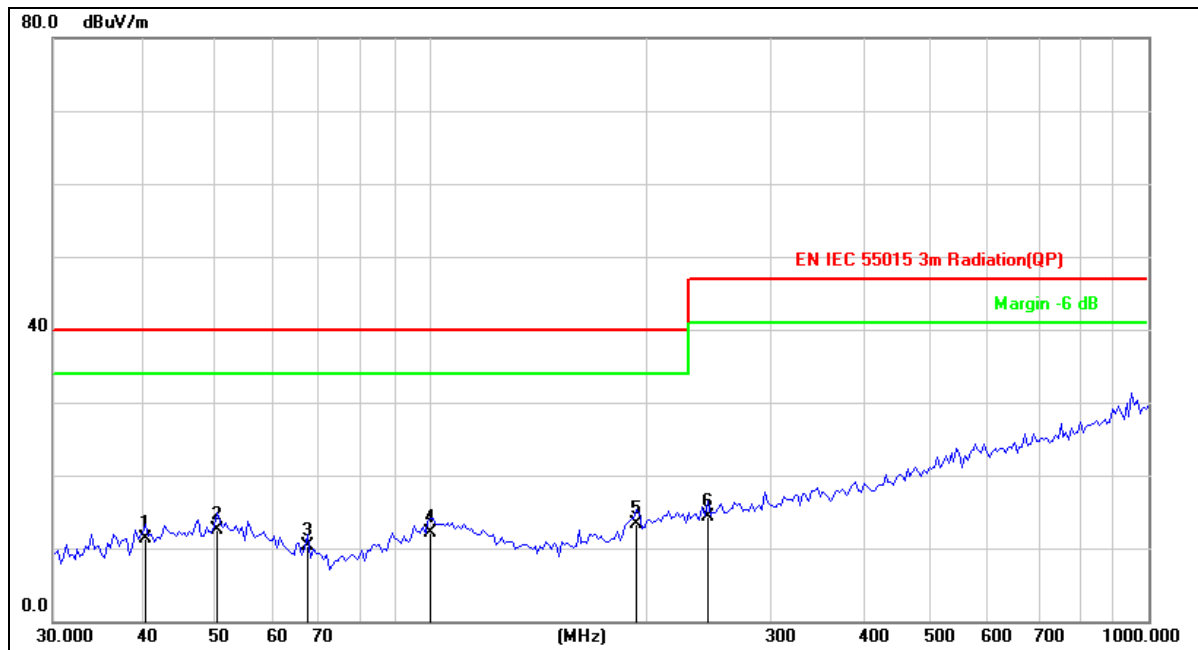

No.	Frequency (MHz)	Reading (dBuV)	Factor (dB/m)	Level (dBuV/m)	Limit (dBuV/m)	Margin (dB)	Det.	Height (cm)	Azimuth (deg)	Remark
1	40.4172	23.86	-12.65	11.21	40.00	-28.79	QP			
2	50.7637	24.07	-11.62	12.45	40.00	-27.55	QP			
3	67.7939	25.17	-14.94	10.23	40.00	-29.77	QP			
4	100.5806	22.71	-10.57	12.14	40.00	-27.86	QP			
5 *	194.1128	23.62	-10.37	13.25	40.00	-26.75	QP			
6	243.8043	23.32	-8.97	14.35	47.00	-32.65	QP			

M/N: SL6
 Op Cond.: Normal Operation
 Comment: DC 4.5V
 Test Spec: Vertical
 Note: Max Lighting

Detailed results are shown below

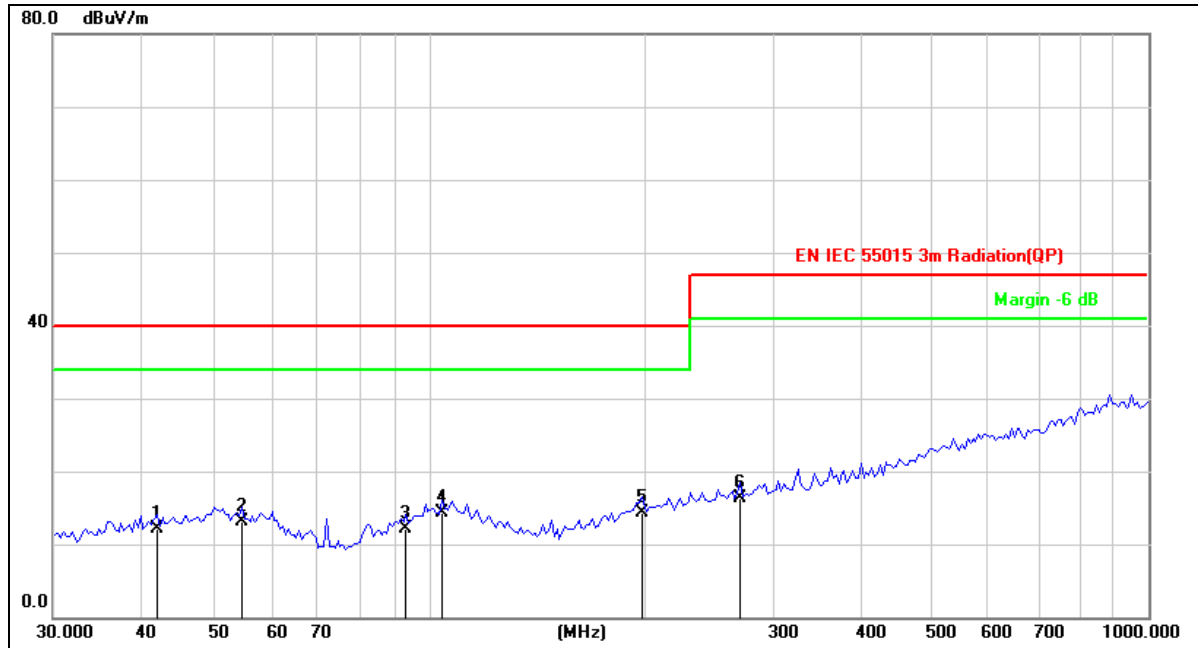

No.	Frequency (MHz)	Reading (dBuV)	Factor (dB/m)	Level (dBuV/m)	Limit (dBuV/m)	Margin (dB)	Det.	Height (cm)	Azimuth (deg)	Remark
1	41.8596	24.50	-12.47	12.03	40.00	-27.97	QP			
2	54.9310	25.30	-12.29	13.01	40.00	-26.99	QP			
3	92.9501	24.16	-12.02	12.14	40.00	-27.86	QP			
4 *	104.1701	24.86	-10.63	14.23	40.00	-25.77	QP			
5	197.5462	24.38	-10.17	14.21	40.00	-25.79	QP			
6	270.8493	24.67	-8.32	16.35	47.00	-30.65	QP			

3.4 MAGNETIC EMISSION MEASUREMENT

3.4.1 MEASUREMENT INSTRUMENTS LIST

Item	Instr.Code	Kind of Equipment	Manufacturer	Type No.	Serial No.	Calibrated until
1	AN-E013	3 Loop Antenna	Da Ze	ZN30401	2944A09491	2021-05-23
3	AN-E026	RF Cable	N/A	ZT06S-NJ-NJ-3M	19044021	2021-05-23
4	AN-E020	EMI Test Receiver	ROHDE&SCHWARZ	ESCI	101358	2021-05-23
5	AN-E058	1# Shielded Room	chengyu	8m*4m*3.3m	N/A	2022-05-06
6	AN-E046	Test Software	Farad	EZ-EMC Ver:ANCI-8A1	N/A	N/A

Remark: " N/A" denotes No Model No. / Serial No. and No Calibration specified.

3.4.2 LIMITS OF MAGNETIC EMISSION MEASUREMENT

Frequency Range	Limits for loop diameter dB(A) ⁽¹⁾
	2m
9KHz-70KHz	88
70KHz-150KHz	88-58
150KHz-3.0MHz	58-22
3.0MHz-30MHz	22

3.4.3 LARGE LOOP ANTENNA SETUP DIAGRAM

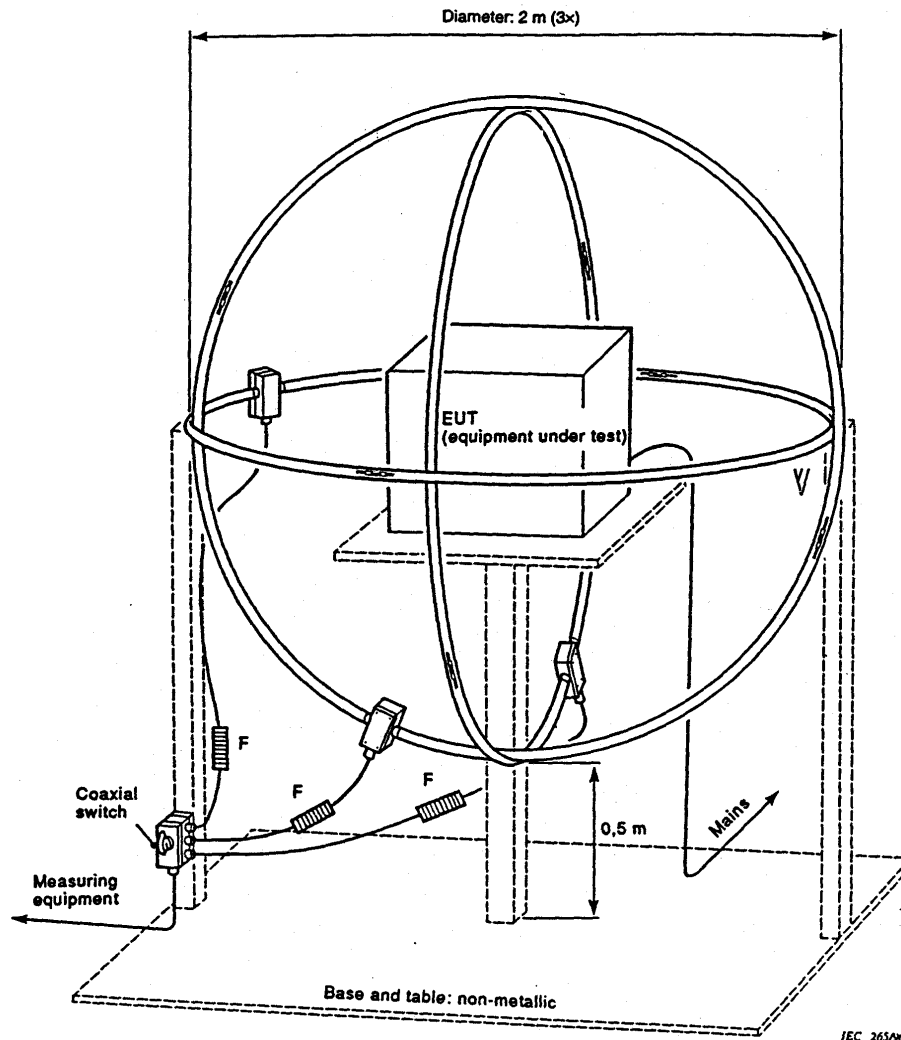

3.4.4 OPERATING CONDITIONS OF THE EUT

The exercise program used during conducted emission measurement was designed to exercise the EUT in a manner similar to a typical use. The exercise sequence is listed as below:

1. Setup the EUT and simulators as shown on 3.3.
2. Turn on the power of all equipments.
3. Start test.

3.4.5 MAGNETIC EMISSION DATA

The quasi-peak limits of the magnetic component of the radiated electromagnetic disturbance field strength in the frequency range **9kHz to 30MHz** measured as a current in 2m, loop antennas around the lighting equipment.

The measurement range of radiated emission, which is from **9kHz to 30MHz**, was investigated. All readings are quasi-peak values with a proper resolution Bandwidth. The initial step in collecting radiated emission data is a spectrum analyzer peak scans of the measurement range for all the test modes and then use test receiver for final measurement. Then the worst modes were reported the following data pages.

3.4.6 TEST RESULTS

EUT:	3xAAA 1xXP LED SL6 Flashlight	Model No.:	SL6
Temperature:	23°C	Relative Humidity:	57%
Pressure:	1008 hPa	Test Power :	DC 4.5V
Test Mode :	Normal Operation		

Remarks :

1. Measurement = Reading + Factor
2. Over Limit (Margin Value)=Measurement level-Limit value.

M/N: SL6
 Op Cond.: Normal Operation
 Comment: DC 4.5V
 Test Spec.: X (2m)
 Note: Max Lighting

Detailed results are shown below

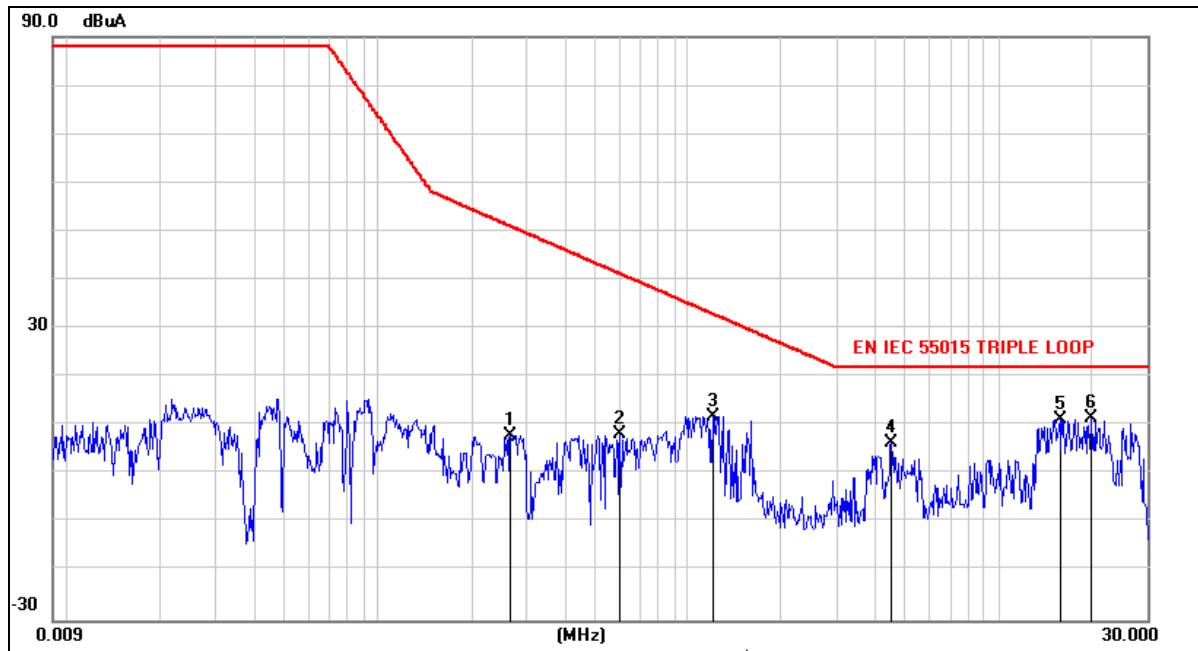

No.	Frequency (MHz)	Reading Level(dBuA)	Factor (dB)	Measurement(dBuA)	Limit (dBuA)	Over (dB)	Detector	Comment
1	0.2671	-2.50	10.45	7.95	51.07	-43.12	peak	
2	0.6018	-2.16	10.41	8.25	41.30	-33.05	peak	
3	1.2016	1.48	10.46	11.94	33.00	-21.06	peak	
4	4.5140	-3.92	10.45	6.53	22.00	-15.47	peak	
5	15.6897	0.84	10.43	11.27	22.00	-10.73	peak	
6 *	19.7860	1.05	10.41	11.46	22.00	-10.54	peak	

M/N: SL6
 Op Cond.: Normal Operation
 Comment: DC 4.5V
 Test Spec.: Y (2m)
 Note: Max Lighting

Detailed results are shown below

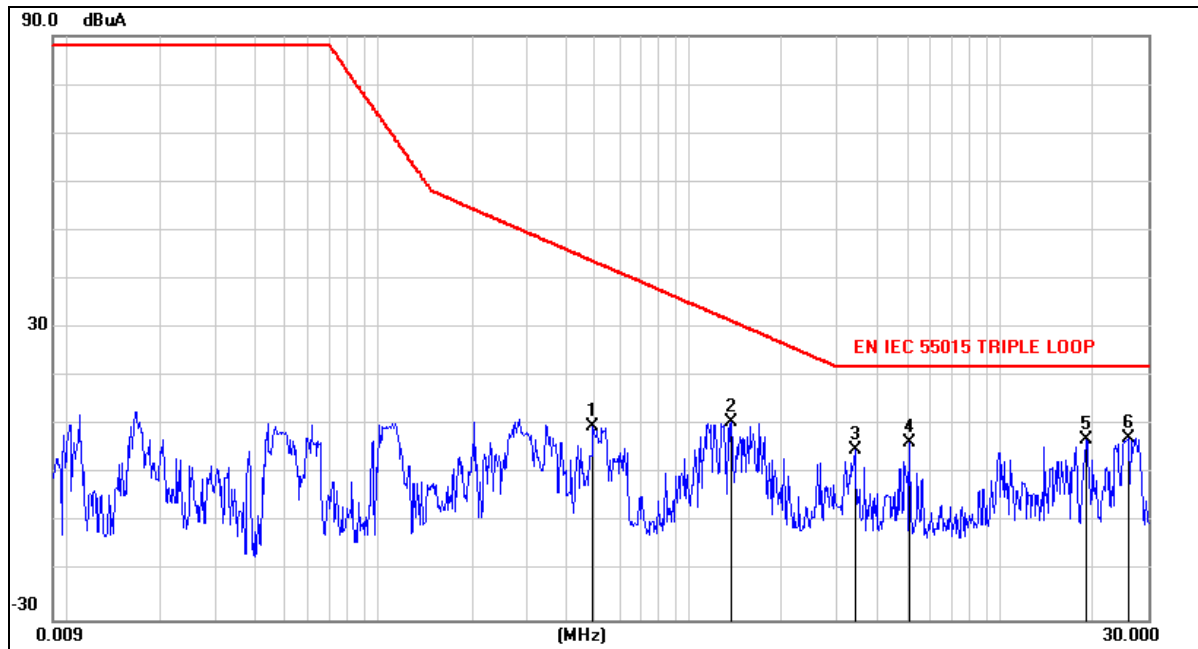

No.	Frequency (MHz)	Reading Level(dBuA)	Factor (dB)	Measurement(dBuA)	Limit (dBuA)	Over (dB)	Detector	Comment
1	0.4939	-0.70	10.40	9.70	43.68	-33.98	peak	
2	1.3700	0.49	10.22	10.71	31.42	-20.71	peak	
3	3.4300	-2.33	7.32	4.99	22.00	-17.01	peak	
4	5.1420	1.20	5.23	6.43	22.00	-15.57	peak	
5	19.0259	9.56	-2.51	7.05	22.00	-14.95	peak	
6 *	25.9573	12.86	-5.59	7.27	22.00	-14.73	peak	

M/N: SL6
 Op Cond.: Normal Operation
 Comment: DC 4.5V
 Test Spec.: Z (2m)
 Note: Max Lighting

Detailed results are shown below

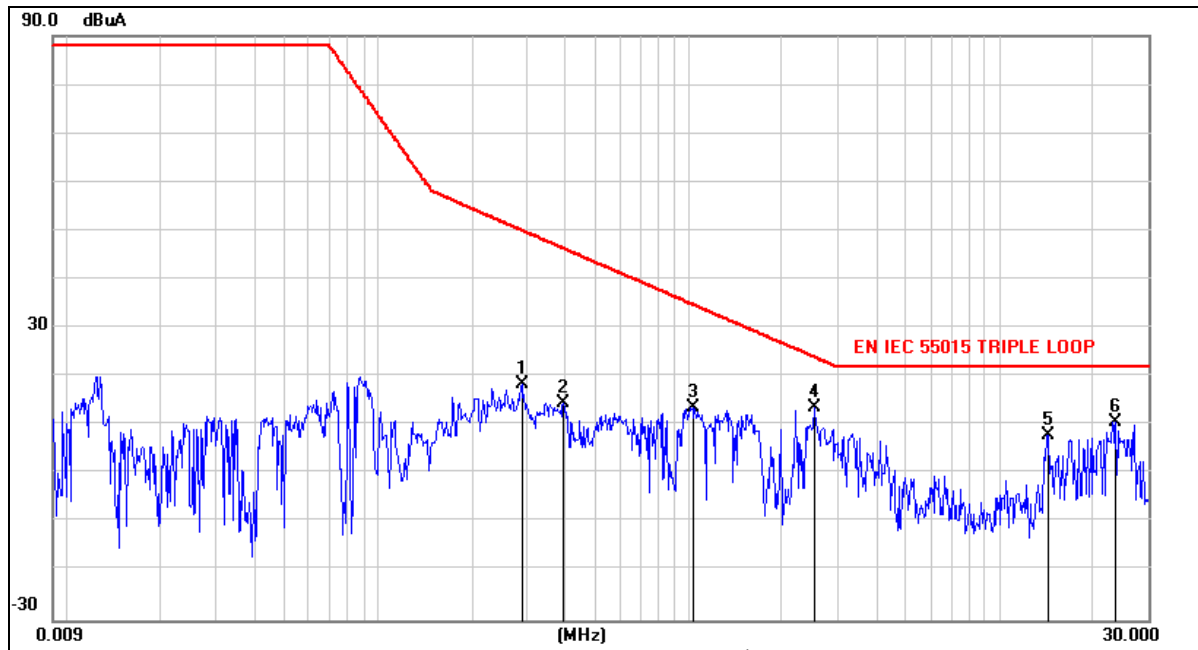

No.	Frequency (MHz)	Reading Level(dBuA)	Factor (dB)	Measurement(dBuA)	Limit (dBuA)	Over (dB)	Detector	Comment
1	0.2898	7.56	10.83	18.39	50.09	-31.70	peak	
2	0.3941	3.96	10.53	14.49	46.39	-31.90	peak	
3	1.0300	3.25	10.46	13.71	34.85	-21.14	peak	
4 *	2.5379	4.69	8.85	13.54	24.01	-10.47	peak	
5	14.2420	7.51	0.39	7.90	22.00	-14.10	peak	
6	23.5940	15.27	-4.58	10.69	22.00	-11.31	peak	

3.5 HARMONICS CURRENT MEASUREMENT

3.5.1 LIMITS OF HARMONICS CURRENT MEASUREMENT

Table 3 – Limits for Class C equipment

Harmonic order <i>h</i>	Maximum permissible harmonic current per watt mA/W	Maximum permissible harmonic current A
3	3,4	2,30
5	1,9	1,14
7	1,0	0,77
9	0,5	0,40
11	0,35	0,33
$13 \leq h \leq 39$ (odd harmonics only)	$\frac{3,85}{h}$	See Table 1

Rated Power $5W \geq$ and $\leq 25W$

Table 2 – Limits for Class C equipment ^a

Harmonic order <i>h</i>	Maximum permissible harmonic current expressed as a percentage of the input current at the fundamental frequency %
2	2
3	$30 \cdot \lambda^b$
5	10
7	7
9	5
$11 \leq h \leq 39$ (odd harmonics only)	3

^a For some Class C products, other emission limits apply (see 7.4).
^b λ is the circuit power factor.

Rated Power $> 25W$

3.5.2 MEASUREMENT INSTRUMENTS LIST

Item	Instr.Code	Kind of Equipment	Manufacturer	Type No.	Serial No.	Calibrated until
1	AN-E036	Harmonic and Flicker Analyzer	EMC PARTNER	Harmonics 1000-1P 230V	0241	2021-05-23

Remark: " N/A" denotes No Model No. / Serial No. and No Calibration specified.

3.5.3 TEST PROCEDURE

- a. Test was performed according to the procedures specified in Clause 5.0 of IEC555-2 and/or Sub-clause 6.2 of EN IEC 61000-3-2 depend on which standard adopted for compliance measurement.
- b. All types of harmonic current and/or voltage fluctuation in this report are assessed by direct measurement using flicker-meter.
- c. For the actual test configuration, please refer to the related Item –EUT Test Photos.

3.5.4 DEVIATION FROM TEST STANDARD

No deviation

3.5.5 TEST SETUP

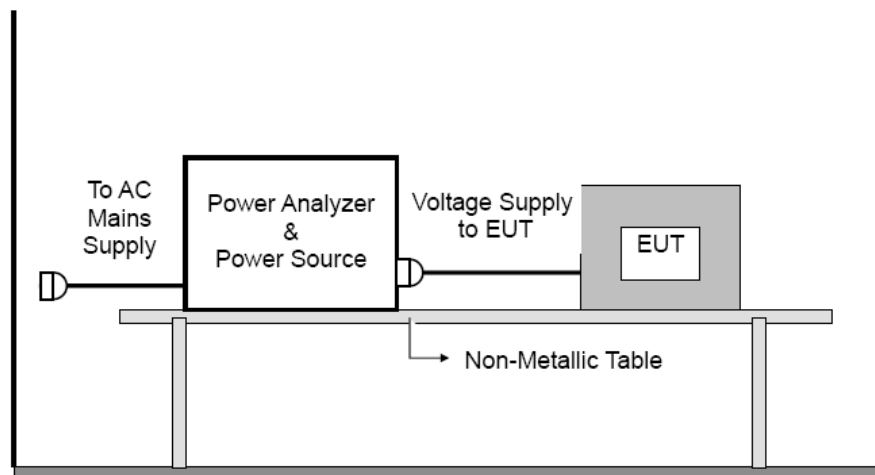

3.5.6 EUT OPERATING CONDITIONS

The EUT tested system was configured as the statements of 3.1.6 Unless otherwise a special operating condition is specified in the follows during the testing.

3.5.7 TEST RESULT

EUT:	/	Model No.:	/
Temperature:	/	Relative Humidity:	/
Pressure:	/	Test Power :	/
Observation Time	/	Test Mode	/

Remark:

- (1) This test is not applicable for DC input products.
- (2) Lamps with input power less than 5W are not suitable for this test.
- (3) Test data see next page.

3.6 VOLTAGE FLUCTUATION AND FLICKS MEASUREMENT

3.6.1 LIMITS OF VOLTAGE FLUCTUATION AND FLICKSMEASUREMENT

Tests	Limits		Descriptions
	IEC555-3	IEC/EN 61000-3-2+A1	
Pst	≤ 1.0, Tp= 10 min.	≤ 1.0, Tp= 10 min.	Short Term Flicker Indicator
Plt	N/A	≤ 0.65, Tp=2 hr.	Long Term Flicker Indicator
dc	≤ 3 %	≤ 3.3 %	Relative Steady-State V-Chang
dmax	≤ 4 %	≤ 4 %	Maximum Relative V-change
d (t)	N/A	≤ 3.3% for > 500 ms	Relative V-change characteristic

3.6.2 MEASUREMENT INSTRUMENTS LIST

Item	Instr.Code	Kind of Equipment	Manufacturer	Type No.	Serial No.	Calibrated until
1	AN-E036	Harmonic and Flicker Analyzer	EMC PARTNER	Harmonics 1000-1P 230V	0241	2021-05-23

Remark: " N/A" denotes No Model No. / Serial No. and No Calibration specified.

3.6.3 TEST PROCEDURE

- a. Harmonic Current Test:
Test was performed according to the procedures specified in Clause 5.0 of IEC555-2 and/or Sub-clause 6.2 of IEC/EN 61000-3-2 depend on which standard adopted for compliance measurement.
- b. Fluctuation and Flickers Test:
Tests was performed according to the Test Conditions/Assessment of Voltage Fluctuations specified in Clause 5.0/6.0 of IEC555-3 and/or Clause 6.0/4.0 of IEC/EN 61000-3-3 depend on which standard adopted for compliance measurement.
- c. All types of harmonic current and/or voltage fluctuation in this report are assessed by direct measurement using flicker-meter.
- d. For the actual test configuration, please refer to the related Item –EUT Test Photos.

3.6.4 DEVIATION FROM TEST STANDARD

No deviation

3.6.5 TEST SETUP

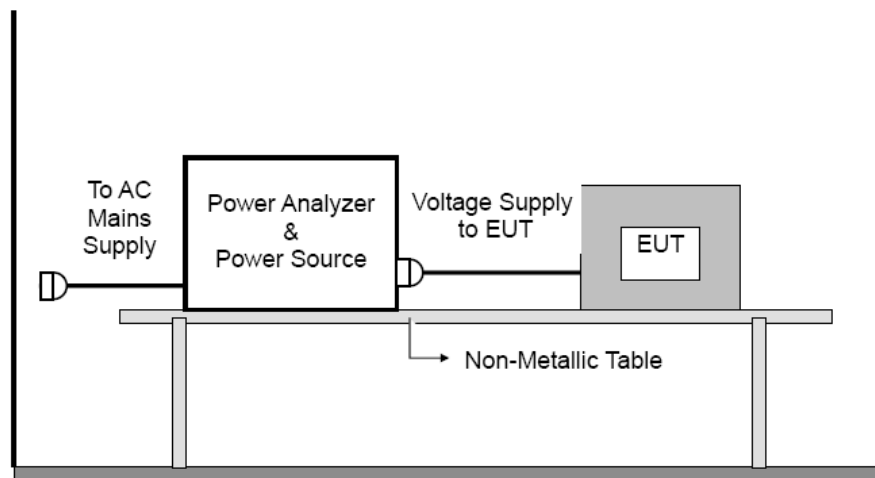

3.6.6 EUT OPERATING CONDITIONS

The EUT tested system was configured as the statements of 3.1.6 Unless otherwise a special operating condition is specified in the follows during the testing.

3.6.7 TEST RESULTS

EUT:	/	Model No.:	/
Temperature:	/	Relative Humidity:	/
Pressure:	/	Test Power :	/
Observation Time	/	Test Mode	/

Remark:

- (1) This test is not applicable for DC input products.
- (2) Lamps with input power less than 600W are not applicable for this test.
- (3) Test data see next page.

4. EMC IMMUNITY TEST

4.1 STANDARD COMPLIANCE/SERVIRITY LEVEL/CRITERIA

Tests Standard No.	Test Specification	Test Mode Test Ports	Perform. Criteria	Remark
1. ESD IEC/EN 61000-4-2	8KV air discharge 4KV contact discharge	Direct Mode	B	PASS
	4KV HCP discharge 4KV VCP discharge	Indirect Mode	B	PASS
2. RS IEC/EN 61000-4-3	80 MHz to 1000 MHz 3V/m(rms), 1 KHz, 80%, AM modulated	Enclosure	A	PASS
3. EFT/Burst IEC/EN 61000-4-4	1.0KV(peak) 5/50ns Tr/Th 5KHz Repetition Freq.	Switching LED string light Port	B	N/A
	0.5 KV(peak) 5/50ns Tr/Th 5KHz Repetition Freq.	CTL/Signal Data Line Port	B	N/A
4. Surges IEC/EN 61000-4-5	For Self-ballast lamp and semi-luminaries: L-N: 0.5 KV L-PE, N-PE: 1 KV For luminaries and independent auxiliary: ≤ 25W: L-N: 0.5 KV L-PE, N-PE: 1 KV >25W: L-N: 1KV L-PE, N-PE: 2 KV 1.2/50(8/20) Tr/Th us	L-N	C	N/A
5 Injected Current IEC/EN 61000-4-6	0.15 MHz to 80 MHz 3V(rms), 1KHz 80%, AM Modulated 150Ω source impedance	AC Power Port DC Power Port CTL/Signal Port	A	N/A
6. Power Frequency Magnetic Field IEC/EN 61000-4-8	50 Hz, 3A/m	Enclosure	A	PASS
7. Volt. Interruptions Volt. Dips IEC/EN 61000-4-11	Voltage dip 30% Interruption 100%	70% / 0%	B / C	N/A

* Remark:

- (1) "N/A": denotes test is not applicable in this Test Report.
- (2) Voltage dip: 30% reduction – Performance Criteria **C**
Voltage Interruption: 100% reduction – Performance Criteria **C**

4.2 GENERAL PERFORMANCE CRITERIA

According to **EN61547:2009** standard, the general performance criteria as following:

Criterion A	During the test no change of the luminous intensity shall be observed and the regulating control, if any shall operate during the test as intended.
Criterion B	During the test the luminous intensity may change to any value. After the test the luminous intensity shall be restored to its initial value within 1 min. Regulating controls need not function during the test, but after the test the mode of the control shall be the same as before the test provided that during the test no mode changing commands were given.
Criterion C	During and after the test any change of the luminous intensity is allowed and the lamps(s) may be extinguished. After the test, within 30 min, all function shall return to normal if necessary by temporary interruption of the mains supply and/or operating the regulating control. Additional requirement for lighting equipment incorporating a starting device.: After the test the lighting equipment is switched off. After half an hour it is switched on again. The lighting equipment shall start and operate as intended.

4.3 GENERAL PERFORMANCE CRITERIA TEST SETUP

The EUT tested system was configured as the statements of **3.1.6** Unless otherwise a special operating condition is specified in the follows during the testing.

4.4 ESD TESTING

4.4.1 TEST SPECIFICATION

Basic Standard:	IEC/EN 61000-4-2
Discharge Impedance:	330 ohm / 150 pF
Required Performance	B
Discharge Voltage:	Air Discharge: 2kV/4kV/8kV (Direct) Contact Discharge: 2kV/4kV (Direct/Indirect)
Polarity:	Positive & Negative
Number of Discharge:	Air Discharge: min. 10 times at each test point Contact Discharge: min. 200 times in total
Discharge Mode:	Single Discharge
Discharge Period:	1 second minimum

4.4.2 MEASUREMENT INSTRUMENTS

Item	Instr.Code	Kind of Equipment	Manufacturer	Type No.	Serial No.	Calibrated until
1	AN-E002	ESD Simulator	Prima	ESD61002B	PR13012530	2021-05-23

Remark: " N/A" denotes No Model No. / Serial No. and No Calibration specified.

4.4.3 TEST PROCEDURE

The test generator necessary to perform direct and indirect application of discharges to the EUT in the following manner:

- a. Contact discharge was applied to conductive surfaces and coupling planes of the EUT. During the test, it was performed with single discharges. For the single discharge time between successive single discharges was at least 1 second. The EUT shall be exposed to at least 200 discharges, 100 each at negative and positive polarity, at a minimum of four test points. One of the test points shall be subjected to at least 50 indirect discharges to the center of the front edge of the horizontal coupling plane. The remaining three test points shall each receive at least 50 direct contact discharges. If no direct contact test points are available, then at least 200 indirect discharges shall be applied in the indirect mode. Test shall be performed at a maximum repetition rate of one discharge per second.
 - Vertical Coupling Plane (VCP):
The coupling plane, of dimensions 0.5m x 0.5m, is placed parallel to, and positioned at a distance 0.1m from, the EUT, with the Discharge Electrode touching the coupling plane. The four faces of the EUT will be performed with electrostatic discharge.
 - Horizontal Coupling Plane (HCP):
The coupling plane is placed under to the EUT. The generator shall be positioned vertically at a distance of 0.1m from the EUT, with the Discharge Electrode touching the coupling plane. The four faces of the EUT will be performed with electrostatic discharge.
- b. Air discharges at insulation surfaces of the EUT. It was at least ten single discharges with positive and negative at the same selected point.
- c. For the actual test configuration, please refer to the related Item –EUT Test Photos.

4.4.4 DEVIATION FROM TEST STANDARD

No deviation

4.4.5 TEST SETUP

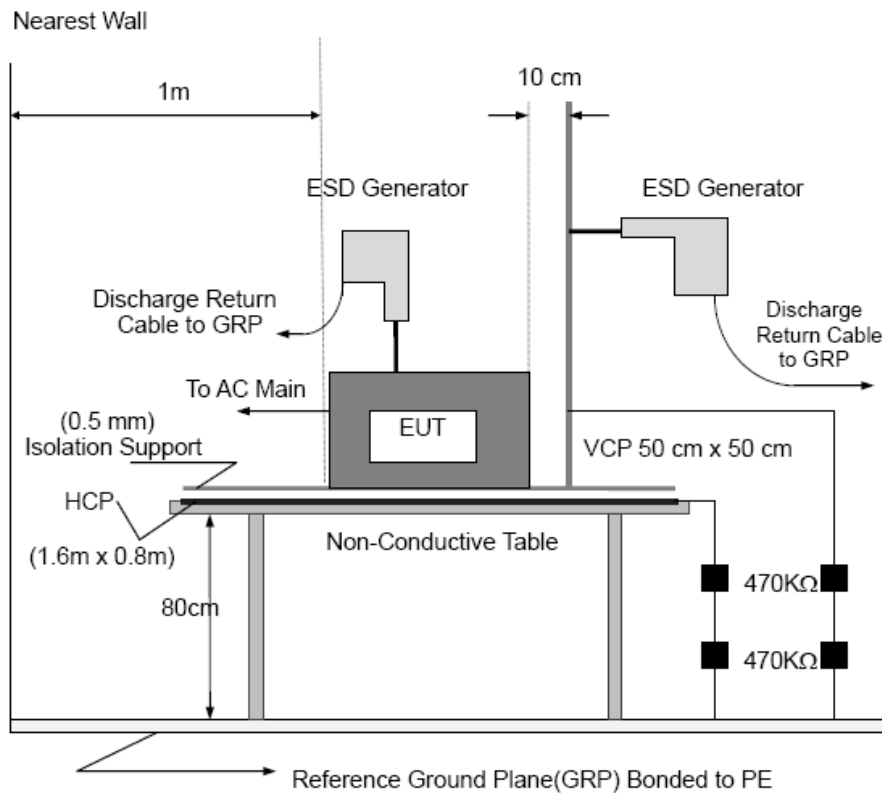

Note:

TABLE-TOP EQUIPMENT

The configuration consisted of a wooden table 0.8 meters high standing on the Ground Reference Plane. The GRP consisted of a sheet of aluminum at least 0.25mm thick, and 2.5 meters square connected to the protective grounding system. A Horizontal Coupling Plane (1.6m x 0.8m) was placed on the table and attached to the GRP by means of a cable with 940k total impedance. The equipment under test, was installed in a representative system as described in section 7 of IEC /EN 61000-4-2, and its cables were placed on the HCP and isolated by an insulating support of 0.5mm thickness. A distance of 1-meter minimum was provided between the EUT and the walls of the laboratory and any other metallic structure.

FLOOR-STANDING EQUIPMENT

The equipment under test was installed in a representative system as described in section 7 of IEC/EN 61000-4-2, and its cables were isolated from the Ground Reference Plane by an insulating support of 0.1-meter thickness. The GRP consisted of a sheet of aluminum that is at least 0.25mm thick, and 2.5meters square connected to the protective grounding system and extended at least 0.5 meters from the EUT on all sides.

4.4.6 TEST RESULTS

Mode	Air Discharge								Contact Discharge							
	2KV		4KV		8KV		12KV		2KV		4KV		6KV		8KV	
Location	P	N	P	N	P	N	P	N	P	N	P	N	P	N	P	N
1	--	--	A	A	B	B	--	--	--	--	--	--	--	--	--	--
2	--	--	--	--	--	--	--	--	A	A	B	B	--	--	--	--
3	-	--	--	--	--	--	--	--	--	--	--	--	--	--	--	--
4	--	--	--	--	--	--	--	--	--	--	--	--	--	--	--	--
5	--	--	--	--	--	--	--	--	--	--	--	--	--	--	--	--
6	-	--	--	--	--	--	--	--	--	--	--	--	--	--	--	--
7	--	--	--	--	--	--	--	--	--	--	--	--	--	--	--	--
8	--	--	--	--	-	--	--	--	--	--	--	--	--	--	--	--
9	-	--	--	--	--	--	--	--	--	--	--	--	--	--	--	--
Criteria	B								B							
Result	B								B							
Judgment	PASS								PASS							

Mode	HCP Discharge								VCP Discharge							
	2KV		4KV		6KV		8KV		2KV		4KV		6KV		8KV	
Location	P	N	P	N	P	N	P	N	P	N	P	N	P	N	P	N
1	-	--	A	A	--	--	--	--	-	--	A	A	--	--	--	--
2	--	--	A	A	--	--	--	--	--	--	A	A	--	--	--	--
3	--	--	A	A	-	--	--	--	--	--	A	A	-	--	--	--
4	-	--	A	A	--	--	--	--	--	--	A	A	--	--	--	--
Criteria	B								B							
Result	A								A							
Judgment	PASS								PASS							

Note:

- 1) P/N denotes the Positive/Negative polarity of the output voltage.
- 2) Test condition:
 Direct discharges: Minimum 20 times (Positive/Negative) at each point.
 Air discharges / Indirect (HCP/VCP): Minimum 20 times (Positive/Negative) at each point.
- 3) Test location(s) in which discharge (Air and contact discharge) to be described as following
- 4) The Indirect (HCP/VCP) discharges description of test point as following:
 1.left side 2.right side 3.front side 4.rear side
- 5) N/A - denotes test is not applicable in this test report

Test Point:

No	Description	No	Description	No	Description
1	Output 4Points	4			
2	Non-metal 5Points	5			
3		6			

4.5 RS TESTING

4.5.1 TEST SPECIFICATION

Basic Standard:	IEC/EN 61000-4-3
Required Performance	A
Frequency Range:	80 MHz - 1000 MHz
Field Strength:	3 V/m
Modulation:	1kHz Sine Wave, 80%, AM Modulation
Frequency Step:	1 % of fundamental
Polarity of Antenna:	Horizontal and Vertical
Test Distance:	3 m
Antenna Height:	1.5 m
Dwell Time:	at least 3 seconds

4.5.2 MEASUREMENT INSTRUMENTS

Item	Kind of Equipment	Manufacturer	Type No.	Serial No.	Calibrated until
1	Signal Generator	Agilent	N517113-50B	MY53050160	2020-10-17
2	Amplifier	A&R	150W1000M3	313157	2020-10-17
3	Amplifier	A&R	50SIG6M2	0342835	2020-10-17
4	Log-periodic Antenna	SCHWARZBECK	STLP 9128E	9128E-012	2021-01-08
5	Microwave log-periodic antenna	SCHWARZBECK	STLP 9149	9149.222	2020-10-17
6	Isotropic Field Probe	A&R	FL700	0342652	2020-10-17
7	10 meter anechoic chamber	Albatross	10m	/	2020-06-26

Remark: " N/A" denotes No Model No. / Serial No. and No Calibration specified.

4.5.3 TEST PROCEDURE

The EUT and support equipment, which are placed on a table that is 0.8 meter above ground and the testing was performed in a fully-anechoic chamber.

The testing distance from antenna to the EUT was 3 meters.

The other condition as following manner:

- a. The field strength level was 3V/m.
- b. The frequency range is swept from 80 MHz to 1000 MHz, with the signal 80%amplitude modulated with a 1kHz sine wave. The rate of sweep did not exceed 1.5×10^{-3} decade/s. Where the frequency range is swept incrementally, the step size was 1% of fundamental.
- c. The dwell time at each frequency shall be not less than the time necessary for the EUT to be able to respond.
- d. The test was performed with the EUT exposed to both vertically and horizontally polarized fields on each of the four sides.
- e. For the actual test configuration, please refer to the related Item –EUT Test Photos.

4.5.4 DEVIATION FROM TEST STANDARD

No deviation

4.5.5 TEST SETUP

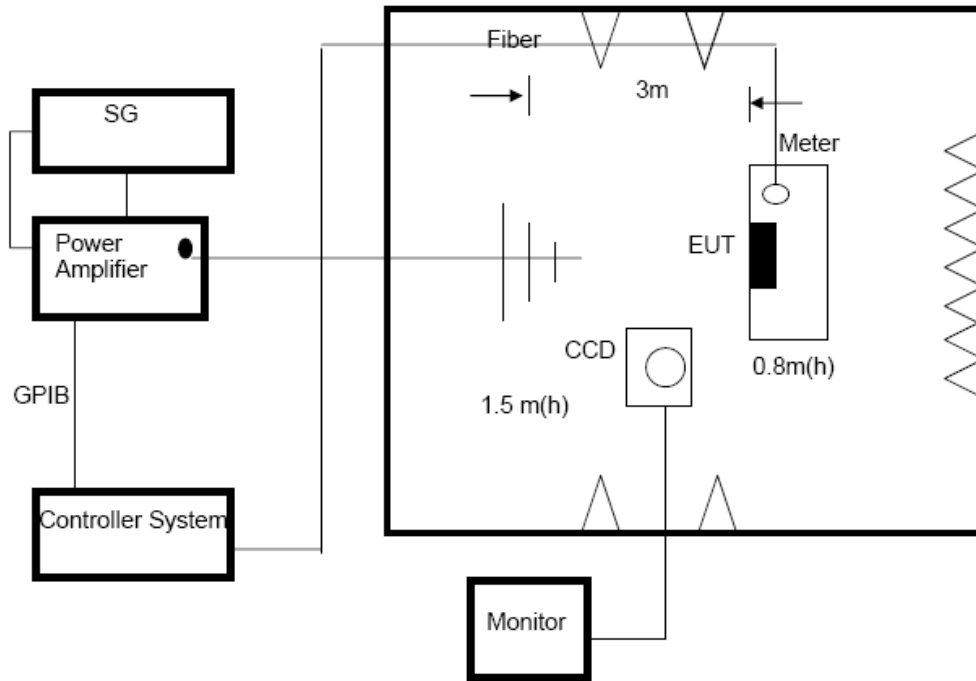

Note:

TABLE-TOP EQUIPMENT

The EUT installed in a representative system as described in section 7 of IEC/EN 61000-4-3 was placed on a non-conductive table 0.8 meters in height. The system under test was connected to the power and signal wire according to relevant installation instructions.

FLOOR-STANDING EQUIPMENT

The EUT installed in a representative system as described in section 7 of IEC/EN 61000-4-3 was placed on a non-conductive wood support 0.1 meters in height. The system under test was connected to the power and signal wire according to relevant installation instructions.

4.5.6 TEST RESULTS

Frequency Range (MHz)	RF Field Position	R.F. Field Strength	Azimuth	Perform. Criteria	Results	Judgment
80MHz - 1000MHz	H / V	3 V/m (rms) AM Modulated 1000Hz, 80%	0	A	A	PASS
			90			
			180			
			270			

Note:

- 1) N/A - denotes test is not applicable in this test report.
- 2) Criteria A: There was no change operated with initial operating during the test.
- 3) Criteria B: The EUT function loss during the test, but self-recoverable after the test.
- 4) Criteria C: The system shut down during the test.

4.6 EFT/BURST TESTING

4.6.1 TEST SPECIFICATION

Basic Standard:	IEC/EN 61000-4-4
Required Performance	B
Test Voltage:	Power Line: 1 kV Signal/Control Line: 0.5 KV
Polarity:	Positive & Negative
Impulse Frequency:	5 kHz
Impulse Wave shape :	5/50 ns
Burst Duration:	15 ms
Burst Period:	300 ms
Test Duration:	Not less than 2 min.

4.6.2 MEASUREMENT INSTRUMENTS

Item	Instr.Code	Kind of Equipment	Manufacturer	Type No.	Serial No.	Calibrated until
1	AN-E032	Electrical Intelligent Transient Generator	Everfine	EMS61000-4B	G114921CA1341115	2021-05-23

Remark: " N/A" denotes No Model No. / Serial No. and No Calibration specified.

4.6.3 TEST PROCEDURE

The EUT and support equipment, are placed on a table that is 0.8 meter above a metal ground plane measured 1m*1m min. and 0.65mm thick min.

The other condition as following manner:

- a. The length of power cord between the coupling device and the EUT should not exceed 1 meter.
- b. Both positive and negative polarity discharges were applied.
- c. The duration time of each test sequential was 1 minute
- d. For the actual test configuration, please refer to the related Item –EUT Test Photos.

4.6.4 DEVIATION FROM TEST STANDARD

No deviation

4.6.5 TEST SETUP

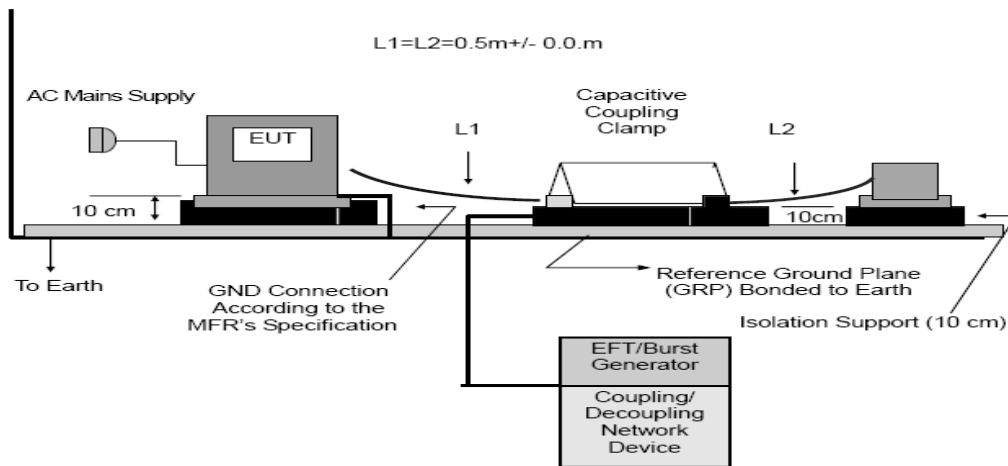
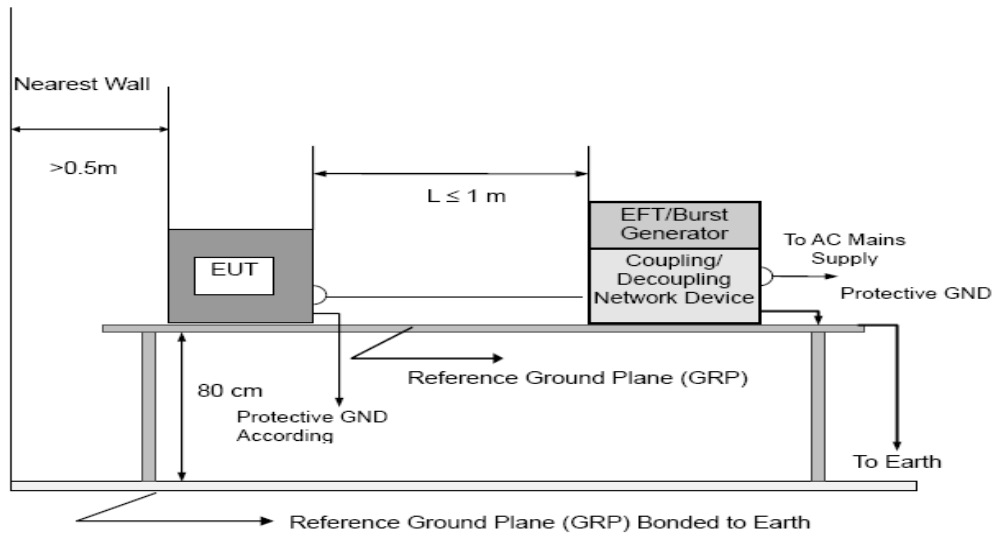

Note:

TABLE-TOP EQUIPMENT

The configuration consisted of a wooden table (0.8m high) standing on the Ground Reference Plane. The GRP consisted of a sheet of aluminum (at least 0.25mm thick and 2.5m square) connected to the protective grounding system. A minimum distance of 0.5m was provided between the EUT and the walls of the laboratory or any other metallic structure.

FLOOR-STANDING EQUIPMENT

The EUT installed in a representative system as described in section 7 of IEC/EN 61000-4-4 and its cables, were isolated from the Ground Reference Plane by an insulating support that is 0.1-meter thick. The GRP consisted of a sheet of aluminum (at least 0.25mm thick and 2.5m square) connected to the protective grounding system.

4.6.6 TEST RESULTS

Mode	(X) AC Power Line		() DC Power Line		() Signal/Control Line	
Test Level	1KV		0.5KV		0.5KV	
Port(s)	Polarity	Results	Polarity	Results	Polarity	Results
Line (L)	P		P		P	
	N		N		N	
Neutral (N)	P		P		P	
	N		N		N	
Ground (PE)	P		P		P	
	N		N		N	
Signal/Control Line	P		P		P	
	N		N		N	
Criteria	B		B		B	
Result	--		--		--	
Judgment	PASS		N/A		N/A	

Note:

- 1) P/N denotes the Positive/Negative polarity of the output voltage.
- 2) N/A - denotes test is not applicable in this test report
- 3) Criteria A: There was no change operated with initial operating during the test.
- 4) Criteria B: The EUT function loss during the test, but self-recoverable after the test.
- 5) Criteria C: The system shut down during the test.

4.7 SURGE TESTING

4.7.1 TEST SPECIFICATION

Basic Standard:	IEC/EN 61000-4-5
Required Performance	B
Wave-Shape:	Combination Wave 1.2/50 us Open Circuit Voltage 8 /20 us Short Circuit Current
Test Voltage:	Power Line: $\pm 0.5KV, \pm 1 KV, \pm 2KV, \pm 4KV,$
Surge Input/Output:	L-N
Generator Source:	2 ohm between networks
Impedance:	12 ohm between network and ground
Polarity:	Positive/Negative
Phase Angle:	90/270
Pulse Repetition Rate:	1 time / min. (maximum)
Number of Tests:	5 positive at 90 and 5 negative at 270

4.7.2 MEASUREMENT INSTRUMENTS

Item	Instr.Code	Kind of Equipment	Manufacturer	Type No.	Serial No.	Calibrated until
1	AN-E001	Lightning surge generator	Prima	SUG61005CX	PR13065597	2021-05-23

Remark: " N/A" denotes No Model No. / Serial No. and No Calibration specified.

4.7.3 TEST PROCEDURE

- a. For test applied to unshielded unsymmetrically operated interconnection lines of EUT:
The surge is applied to the lines via the capacitive coupling. The coupling /decoupling networks shall not influence the specified functional conditions of the EUT. The interconnection line between the EUT and the coupling/decoupling networks shall be 2 meters in length (or shorter).
- b. For test applied to unshielded symmetrically operated interconnection /telecommunication lines of EUT:
The surge is applied to the lines via gas arrestors coupling. Test levels below the ignition point of the coupling arrestor cannot be specified. The interconnection line between the EUT and the coupling/decoupling networks shall be 2 meters in length (or shorter).
- c. For the actual test configuration, please refer to the related Item –EUT Test Photos.

4.7.4 DEVIATION FROM TEST STANDARD

No deviation

4.7.5 TEST SETUP

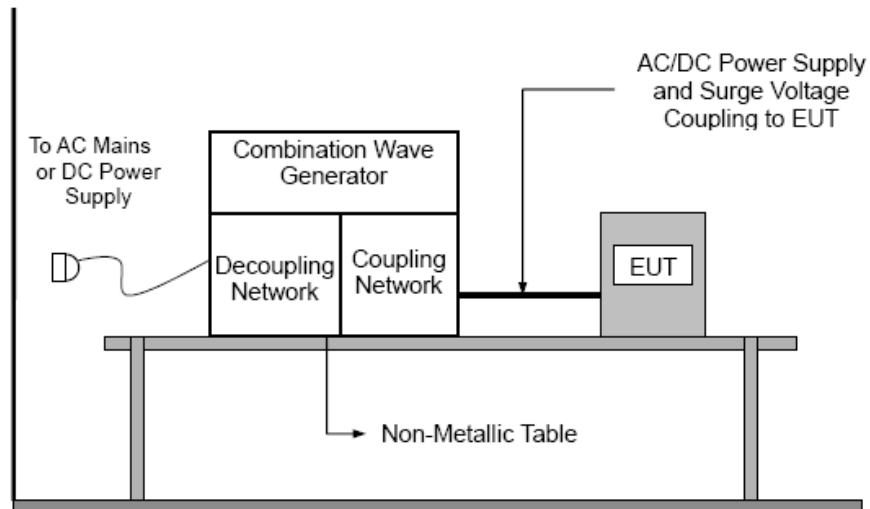

4.7.6 TEST RESULTS

Wave Form EUT Ports Tested	1.2/50(8/20)Ti/Th us						Criteria	Judgment
	Polarity	Phase	Voltage					
			0.5kV	1kV	2kV	4kV		
L - N	+/-	0°					N/A	N/A
	+	90°						
	+/-	180°						
	-	270°						
L - PE	+/-	0°					N/A	N/A
	+	90°						
	+/-	180°						
	-	270°						
N - PE	+/-	0°					N/A	N/A
	+	90°						
	+/-	180°						
	-	270°						
Signal Line (N/A)	+/-	0°					N/A	N/A
	+/-	90°						
	+/-	180°						
	+/-	270°						
Signal Line (N/A)	+/-	0°					N/A	N/A
	+/-	90°						
	+/-	180°						
	+/-	270°						

Note:

- 1) P/N denotes the Positive/Negative polarity of the output voltage.
- 2) Polarity and Numbers of Impulses: 5 Pst / Ngt at each tested mode
- 3) N/A - denotes test is not applicable in this Test Report
- 4) All voltages of the lower levels shall be satisfied

4.8 INJECTION CURRENT TESTING

4.8.1 TEST SPECIFICATION

Basic Standard:	IEC/EN 61000-4-6
Required Performance	A
Frequency Range:	0.15 MHz - 80 MHz
Field Strength:	3 Vr.m.s.
Modulation:	1kHz Sine Wave, 80%, AM Modulation
Frequency Step:	1 % of fundamental
Dwell Time:	at least 3 seconds

4.8.2 MEASUREMENT INSTRUMENTS

Item	Kind of Equipment	Manufacturer	Type No.	Serial No.	Calibrated until
1	CONDUCTED IMMUNITY TEST SYSTEM	FRANKONIA	CIT-10	102D1253	2020-10-17
2	CDN	FRANKONIA	CDN M2+M3	A3011059	2020-10-17
3	Electromagnetic clamp	FRANKONIA	KEMZ-801	21044	2020-10-17

Remark: " N/A" denotes No Model No. / Serial No. and No Calibration specified.

4.8.3 TEST PROCEDURE

The EUT and support equipment, are placed on a table that is 0.8 meter above a metal ground plane measured 1m*1m min. and 0.65mm thick min.

The other condition as following manner:

- a. The field strength level was 3V.
- b. The frequency range is swept from 150 KHz to 80 MHz, with the signal 80%amplitude modulated with a 1kHz sine wave. The rate of sweep did not exceed 1.5×10^{-3} decade/s. Where the frequency range is swept incrementally, the step size was 1% of fundamental.
- c. The dwell time at each frequency shall be not less than the time necessary for the EUT to be able to respond.
- d. For the actual test configuration, please refer to the related Item –EUT Test Photos.

4.8.4 DEVIATION FROM TEST STANDARD

No deviation

4.8.5 TEST SETUP

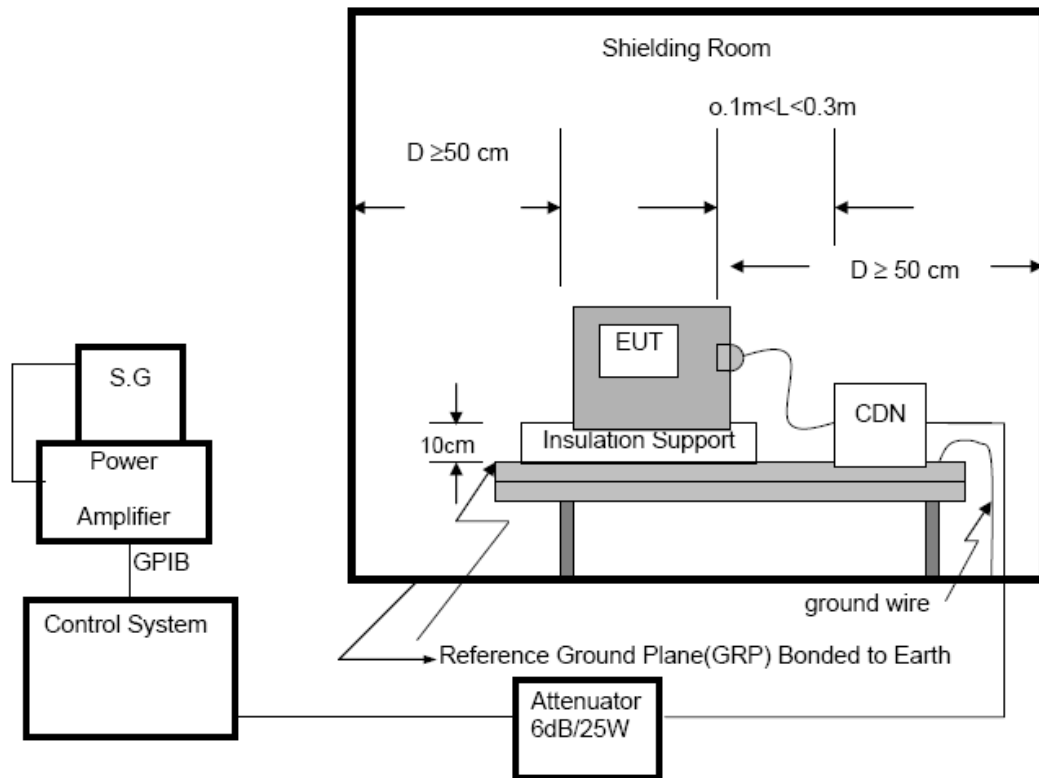

For the actual test configuration, please refer to the related Item –EUT Test Photos.

NOTE:

FLOOR-STANDING EQUIPMENT

The equipment to be tested is placed on an insulating support of 0.1 meters height above a ground reference plane. All relevant cables shall be provided with the appropriate coupling and decoupling devices at a distance between 0.1 meters and 0.3 meters from the projected geometry of the EUT on the ground reference plane.

4.8.6 TEST RESULTS

Test Ports (Mode)	Freq. Range MHz)	Field Strength	Perform. Criteria	Results	Judgment
Input/ Output AC. Power Port	0.15 ---80	3V(rms) AM Modulated 1000Hz, 80%	A	--	N/A
Input/ Output DC. Power Port	0.15 --- 80		A	--	N/A
Signal Line (N/A)	0.15 --- 80		A	--	N/A

Note:

- 1) N/A - denotes test is not applicable in this Test Report.

4.9 VOLTAGE INTERRUPTION/DIPS TESTING

4.9.1 TEST SPECIFICATION

Basic Standard:	IEC/EN 61000-4-11
Required Performance:	C (For 30% Voltage Dips) B (For 100% Voltage Interruptions)
Test Duration Time:	Minimum three test events in sequence
Interval between Event:	Minimum ten seconds
Phase Angle:	0°-360°
Test Cycle:	3 times

4.9.2 MEASUREMENT INSTRUMENTS

Item	Instr.Code	Kind of Equipment	Manufacturer	Type No.	Serial No.	Calibrated until
1	AN-E031	Voltage Dips And Interruptions Generator	Everfine	EMS61000-11K	G113317CA8341117	2021-05-23

Remark: " N/A" denotes No Model No. / Serial No. and No Calibration specified.

4.9.3 TEST PROCEDURE

The EUT shall be tested for each selected combination of test levels and duration with a sequence of three dips/interruptions with intervals of 10 s minimum (between each test event). Each representative mode of operation shall be tested. Abrupt changes in supply voltage shall occur at zero crossings of the voltage waveform.

4.9.4 DEVIATION FROM TEST STANDARD

No deviation

4.9.5 TEST SETUP

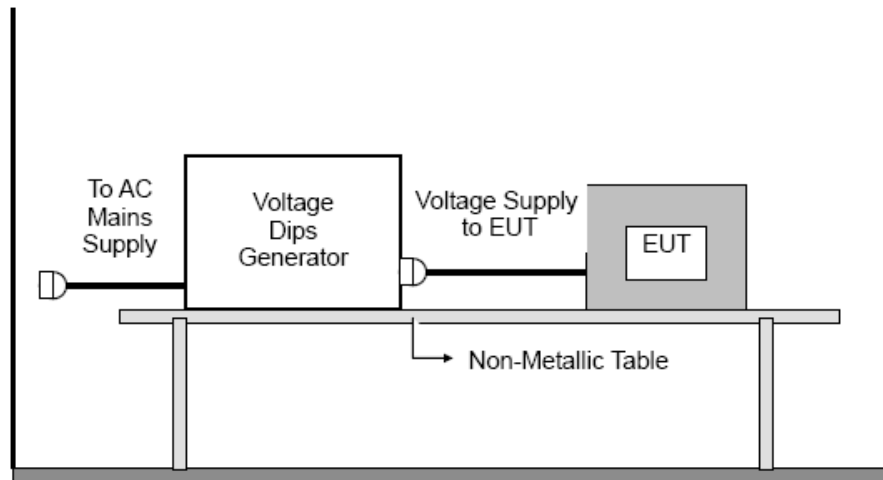

For the actual test configuration, please refer to the related Item –EUT Test Photos.

4.9.6 TEST RESULTS

Test Power: 120Vac, 60Hz

Voltage Reduction	Periods	Perform Criteria	Results	Judgment
Voltage dip 30%	10	C	--	N/A
Interruption100%	0.5	B	--	N/A

Test Power: 230Vac, 50Hz

Voltage Reduction	Periods	Perform Criteria	Results	Judgment
Voltage dip 30%	10	C	--	N/A
Interruption100%	0.5	B	--	N/A

Note:

- 1). N/A - denotes test is not applicable in this test report.

4.10 POWER-FREQUENCY MAGNETIC FILDS

4.10.1 MEASUREMENT INSTRUMENTS

Item	Kind of Equipment	Manufacturer	Type No.	Serial No.	Calibrated until
1	Magnetic Field Tester	EMC-PARTNER	MF1000-1	121	2020-10-17

Remark: " N/A" denotes No Model No. / Serial No. and No Calibration specified.

4.10.2 TEST LEVEL AND PERFORMANCE CRITERION

Level	Magnetic Field Strength A/m	Performance criterion
2	3	A

4.10.3 TEST PROCEDURE

The EUT shall be subjected to the test magnetic field by using the induction coil of standard dimensions (1m*1m) and shown in Section 13.3 The induction coil shall then be rotated by 90 ein order to expose the EUT to the test field with different orientations. .

4.10.4 DEVIATION FROM TEST STANDARD

No deviation

4.10.5 TEST SETUP

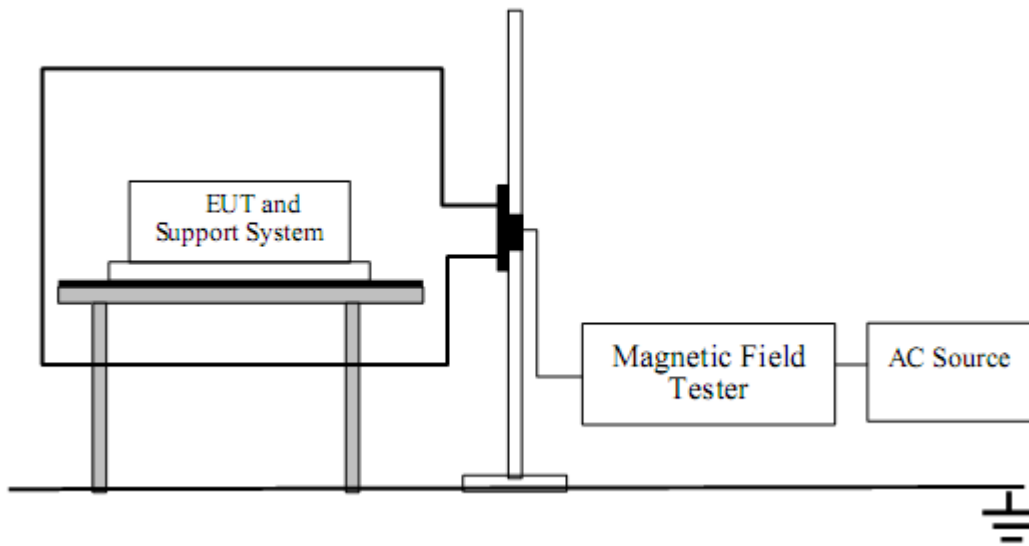

4.10.6 TEST RESULTS

Operation Mode	Test Level	Testing Duration	Coil Orientation	Required	Observation	Result (Pass/Fail)
Normal operation	3A/m	5 min / coil	X	A	A	Pass
	3A/m	5 min / coil	Y	A	A	Pass
	3A/m	5 min / coil	Z	A	A	Pass

Note:

Operation as intend, no loss of function during test and after test

5. ATTACHMENT
5.1 EUT Test Photo

Radiated Measurement Photo



Magnetic Emission Test Photo

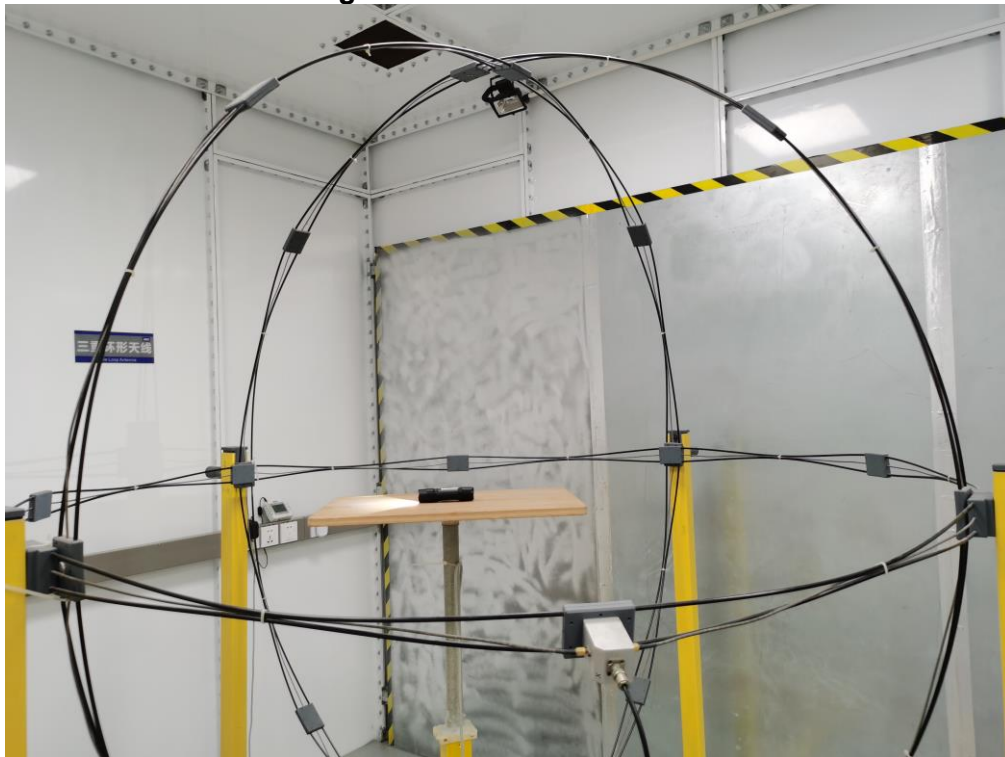

ESD Measurement Photo

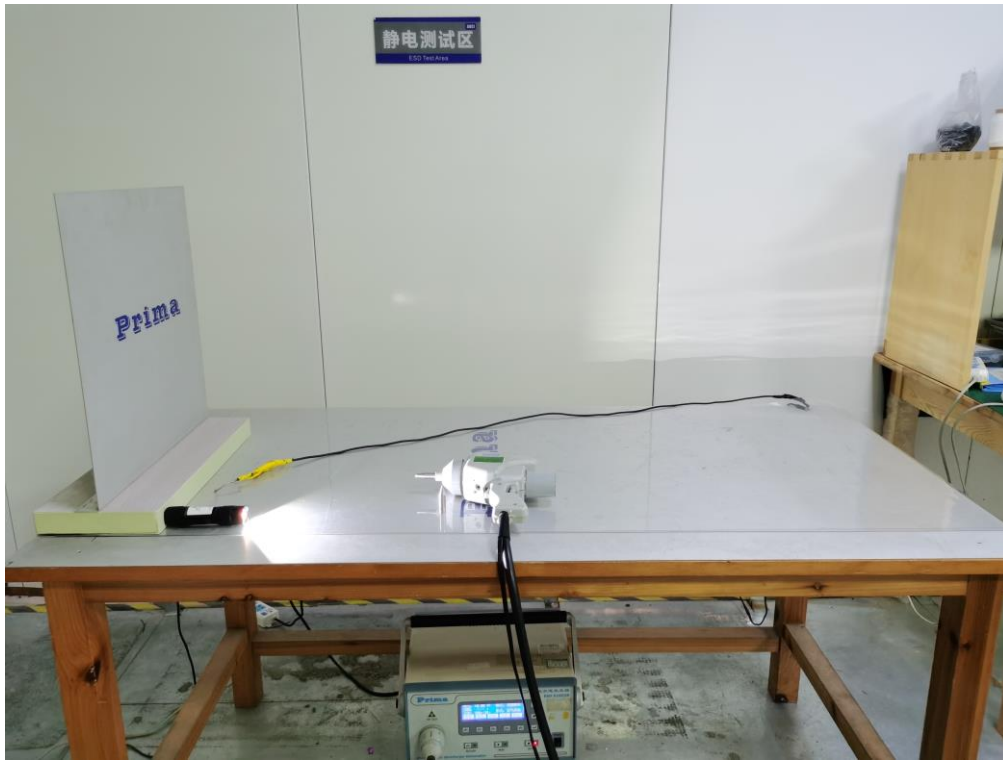

5.2 EUT Photo



Figure 1. Overall view of unit



Figure 2. Overall view of unit



Figure 3. Internal view of unit



Figure 4. LED view of unit

***** End of Page *****