





Installation Manual AIR-TO-WATER HEAT PUMP INDOOR UNIT

WH-CME8L

Required tools for Installation Works



| | | | |
|---|---------------------------------|----|----------------|
| 1 | Philips screw driver | 7 | Measuring tape |
| 2 | Level gauge | 8 | Thermometer |
| 3 | Electric drill, hole core drill | 9 | Megameter |
| 4 | Spanner | 10 | Multimeter |
| 5 | Reamer | 11 | Torque wrench |
| 6 | Knife | 12 | Hand gloves |

Explanation of symbols displayed on the indoor unit or outdoor unit.



| | | |
|---|----------------|---|
|  | WARNING | This symbol shows that this equipment uses a flammable refrigerant with safety A3 group per ISO 817. If the refrigerant is leaked, together with an external ignition source, there is a possibility of fire / explosion. |
|  | CAUTION | This symbol shows that the Installation Manual should be read carefully. |
|  | CAUTION | This symbol shows that a service personnel should be handling this equipment with reference to the Installation Manual. |
|  | CAUTION | This symbol shows that there is information included in the Operation Manual and/or Installation Manual. |

SAFETY PRECAUTIONS

- Read the following "SAFETY PRECAUTIONS" carefully before installation of Air-To-Water Heat Pump Indoor Unit.
- This AIR-TO-WATER HEAT PUMP INDOOR UNIT operates in combination with an outdoor unit containing refrigerant R290. This product and the outdoor unit must only be installed or serviced by qualified personnel. Refer to National, State, Territory and local legislation, regulations, codes, installation & operation manuals, before the installation, maintenance and/or service of these products.
- Electrical works and water installation works must be done by licensed electrician and licensed water system installer respectively. Be sure to use the correct rating and main circuit for the model to be installed.
- The caution items stated here must be followed because these important contents are related to safety. The meaning of each indication used is as below. Incorrect installation due to ignorance or negligence of the instructions may cause harm or damage, and the seriousness is classified by the following indications.





| | | |
|--|----------------|---|
|  | WARNING | This indication shows the possibility of causing death or serious injury. |
|  | CAUTION | This indication shows the possibility of causing injury or damage to properties only. |























The items to be followed are classified by the symbols:

| | |
|---|--|
|  | Symbols with white background indicate prohibited items. |
|  | Symbols with dark background must be executed. |



- Carry out test run to confirm that no abnormality occurs after the installation. Then explain to the user how to operate, care and maintain the product as described in the operating instructions.
- This installation manual should be handed over with the unit after installation.
- Please remind the customer to keep the installation manual for future reference.
- If there is any doubt about the installation procedure or operation, always contact the authorized dealer for advice and information.

WARNING

| | |
|--|---|
|  | Do not use means to accelerate the defrosting process or to clean, other than those recommended by the manufacturer. Any unfit method or using incompatible material may cause product damage, burst or serious injury. |
|  | Do not use unspecified, modified, jointed or extension cable for power supply cable. Do not share the single outlet with other electrical appliances. Poor contact, poor insulation or over current may cause electrical shock or fire. |
|  | Do not tie up the power supply cable into a bundle by band. Abnormal temperature rise on power supply cable may happen. |
|  | Do not purchase unauthorized electrical parts for installation, service, maintenance and etc.. They might cause electrical shock or fire. |
|  | Keep plastic bag (packaging material) away from small children, it may cling to nose and mouth and prevent breathing. |

|  | Do not pierce or burn as the appliance is pressurized. Do not expose the appliance to heat, flame, sparks, or other sources of ignition. Else, it may explode and cause injury or death. | | | | | | |
|--|---|------------------------------------|-----------------------|---------------------|------|-----------------------------------|------|
|  | Do not place containers of liquid on top of the indoor unit. Leakage or spillage of liquid into the indoor unit may cause damage to the indoor unit or cause a fire. | | | | | | |
|  | Use the specified connection cables for the indoor unit and outdoor unit, and connect the indoor unit and outdoor unit securely, referring to 3 CONNECT THE CABLE TO THE INDOOR UNIT . Tighten the cable so that no external force is applied to the terminal. Incomplete connection or fixing may cause heat generation or ignition of the connection. | | | | | | |
|  | For electrical work, follow the national regulation, legislation and this installation manual. An independent circuit and single outlet must be used. If electrical circuit capacity is not enough or defect found in the electrical work, it may cause electrical shock or fire. | | | | | | |
|  | For water circuit installation work, follow to relevant European and national regulations (including EN61770) and local plumbing and building regulation codes. | | | | | | |
|  | Engage authorized dealer or specialist for installation. If installation done by the user is incorrect, it will cause electrical shock or fire. | | | | | | |
|  | Comply with national wiring rules or country-specific safety measures in terms of residual current (Installing Residual Current Device (RCD) is strongly recommended). | | | | | | |
|  | Only use supplied or specified parts for installation. Other parts may cause the equipment to drop, vibrate, leak, catch fire or cause an electrical shock. | | | | | | |
|  | When installing electrical equipment at wooden building of metal lath or wire lath, in accordance with electrical facility standard, no electrical contact between equipment and building is allowed. Insulator must be installed in between. | | | | | | |
|  | Any work carried out on the Indoor Unit after removing any panels which is secured by screws, must be carried out under the supervision of authorized dealer and licensed installation contractor. | | | | | | |
|  | All power circuits must be disconnected before accessing the unit terminals. | | | | | | |
|  | This installation may be subjected to building regulation approval applicable to respective country that may require to notify the local authority before installation. | | | | | | |
|  | Do not install the indoor unit where flammable gases may leak. If gas leaks and accumulates around the unit, it may cause a fire. | | | | | | |
|  | Ensure that all wiring polarity is correct. Otherwise, this may cause electrical shock or fire. | | | | | | |
|  | This equipment must be properly earthed. Earth line must not be connected to gas pipe, water pipe, earth of lightning rod and telephone. Otherwise, it may cause electrical shock in case of equipment breakdown or insulation breakdown. | | | | | | |
|  CAUTION | | | | | | | |
|  | Prevent liquid or vapour from entering sumps or sewers since vapour is heavier than air and may form suffocating atmospheres. | | | | | | |
|  | Do not install in humid areas such as laundry rooms. This may cause rust and damage to the unit. | | | | | | |
|  | Ensure that the insulation of the power cable does not come into contact with hot areas (e.g. water pipes) to prevent insulation failure (melting) of the power cable. | | | | | | |
|  | Do not apply excessive force to the water pipes as this may damage them. Water leaks may cause flooding and damage to other property. | | | | | | |
|  | Select an installation location which is easy for maintenance. Incorrect installation, service or repair of this Indoor Unit may result in loss damage or injury and/or property. | | | | | | |
|  | <p>Connection of power supply to the Indoor Unit</p> <ul style="list-style-type: none"> • Power supply point should be in easily accessible place for power disconnection in case of emergency. • Comply with local national wiring standard, regulation, and this installation manual. • It should be to make permanent connection to circuit breaker. <ul style="list-style-type: none"> - Power supply: use an approved 4-poles circuit breaker with a minimum contact gap of 3.0 mm. Its rated current depends on the capacity of external heater. Refer to below table. <table border="1" data-bbox="156 1173 655 1292"> <thead> <tr> <th>EXTERNAL HEATER Capacity a [kW]</th> <th>Breaker rated current</th> </tr> </thead> <tbody> <tr> <td>$a \leq 9\text{kW}$</td> <td>20 A</td> </tr> <tr> <td>$9\text{kW} < a \leq 18\text{kW}$</td> <td>40 A</td> </tr> </tbody> </table> | EXTERNAL HEATER Capacity a [kW] | Breaker rated current | $a \leq 9\text{kW}$ | 20 A | $9\text{kW} < a \leq 18\text{kW}$ | 40 A |
| EXTERNAL HEATER Capacity a [kW] | Breaker rated current | | | | | | |
| $a \leq 9\text{kW}$ | 20 A | | | | | | |
| $9\text{kW} < a \leq 18\text{kW}$ | 40 A | | | | | | |

Attached Accessories

| No. | Accessories part | Qty. |
|-----|--|------|
| 1 | Installation plate  | 1 |
| 2 | Network adaptor (CZ-TAW1*)  | 1 |

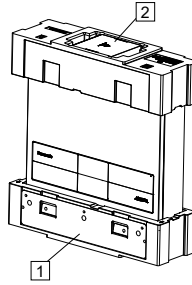

Optional Accessories

| No. | Accessories part | Qty. |
|-----|---|------|
| 3 | Remote controller Case (PAW-A2W-COV-KL) | 1 |
| 4 | Extension Cable (CZ-TAW1-CBL) | 1 |
| 5 | Optional PCB (CZ-NS7P) | 1 |
| 6 | Remote controller (CZ-RTW2-1)*1 | 1 |

*1 If you need the 2nd remote controller, buy [6] and set it up.

Field Supply Accessories (Optional)

| No. | Part | Model | Specification |
|------|-----------------------------------|-------------------------|--------------------|
| i | 2-way valve kit *Cooling model | Electromotoric Actuator | — |
| | | 2-port Valve | — |
| ii | 3-way valve kit | Electromotoric Actuator | — |
| | | 3-port Valve | — |
| iii | Room thermostat | Wired | PAW-A2W-RTWIRED |
| | | Wireless | PAW-A2W-RTWIRELESS |
| iv | Pump | — | AC 230V, 0.6 A max |
| v | Buffer tank sensor | — | AC 230V, 3.0 A max |
| vi | Outdoor sensor | PAW-A2W-TSBU | — |
| vii | Zone water sensor | PAW-A2W-TSOD | — |
| viii | Zone room sensor | PAW-A2W-TSHC | — |
| ix | Zone room sensor | PAW-A2W-TSRT | — |
| x | Solar sensor | PAW-A2W-TSSO | — |
| x | Outlet sensor | PAW-A2W-TSBH | — |

■ It is recommended to purchase the field supply accessories listed in above table.

Dimension Diagram

Unit: mm

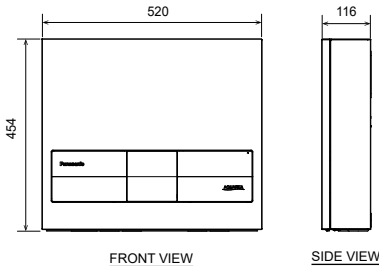

Main Components Diagram

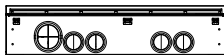
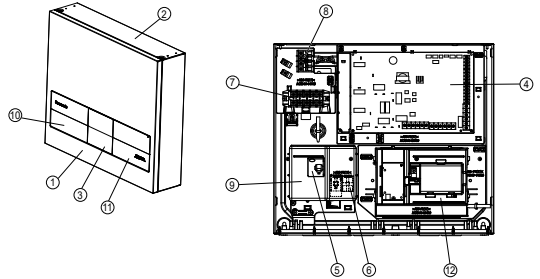

BOTTOM VIEW

- ① Front cover
- ② Enclosure
- ③ Remote controller
- ④ PCB
- ⑤ RCCB/ELCB
- ⑥ Terminal 1 (ID-OD Communication)
- ⑦ Terminal 2 (For Heater)
- ⑧ Terminal 3 (For Heater OLP (Bi metal thermostat) & sensor)
- ⑨ Terminal Cover
- ⑩ Left decoration panel
- ⑪ Right decoration panel
- ⑫ Network adaptor holder

1 SELECT THE BEST LOCATION

Obtain customer's approval before deciding the installation location.

- Ensure that there are no heat sources or vapours near the Indoor Unit.
- Good air circulation in the room.
- Ensure to keep distance of spaces as illustrated below from walls, ceilings, or other obstacles.
- A place where flammable gas leaking might not occur.
- The Indoor Unit must be installed on a vertical wall.
- When installing electrical equipment in a wooden building of metal lath or wire lath, according to electrical facility technical standards, no electrical contact between equipment and building is allowed. An insulator must be installed in between them.
- Do not install the Indoor Unit at outdoor. This is designed for indoor installation only.

Required space for installation

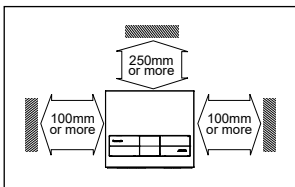

Installation position

The mounting wall is strong and solid enough to prevent it from vibration.

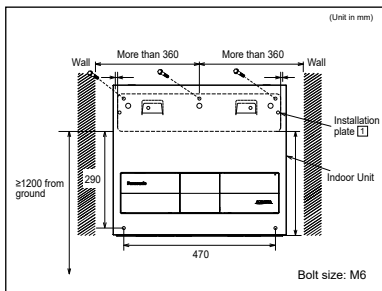

The centre of the installation plate should be more than 360 mm from the right and left of the wall.

The distance from the installation plate edge to the ground should be more than 1200 mm.

- Always mount the installation plate horizontally by aligning the marking thread and using a level gauge.
- Mount the installation plate on the wall with 3 sets of plug, screw, and washer with size M6 (field supply). The combined thickness of the screw head and washer must be less than 6 mm.

2 INSTALL THE INDOOR UNIT AND OPEN THE FRONT COVER

WARNING

- ⚠ This section is for authorized and licensed electrician only. Work behind the front cover ① secured by screws must only be carried out under the supervision of a qualified contractor, installation engineer, or service person.

Hang the Indoor Unit on the installation plate

1. Engage the slots on the Indoor Unit to the hooks of installation plate ①.

2. Ensure the hooks are properly seated on the installation plate by moving it left and right.

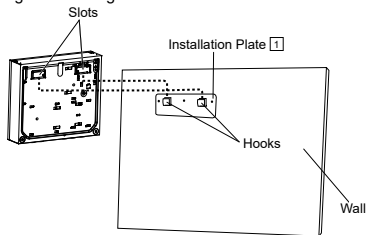

Open the front cover

Before opening the front cover ① of the Indoor Unit, always switch off all power supplies (e.g. the Indoor Unit power supply, the outdoor unit power supply, and the heater power supply).

1. Remove the 2 mounting screws located at the top of the enclosure ②.
2. Gently pull the upper section of the front cover ① towards you.
3. Gently rotate the front cover ① to open 180 degrees.

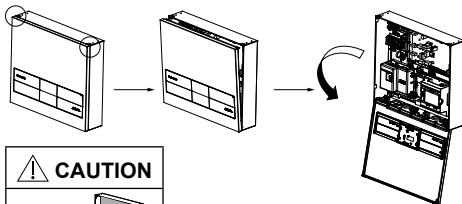

Fix the Indoor Unit

Fasten two screws (M6) at the bottom holes of the Indoor Unit.

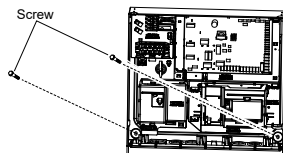

An example of system installation

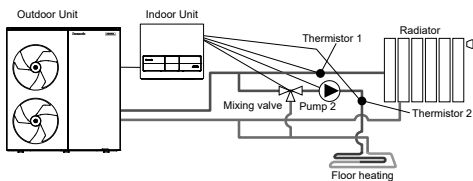

3 CONNECT THE CABLE TO THE INDOOR UNIT

WARNING

- ⚠ This section is for authorized and licensed electrician only. Work behind the front cover ① (secured by screws) must only be carried out under the supervision of a qualified contractor, installation engineer, or service person.

- Remove the terminal cover.
Remove one screw from the terminal cover ⑨, and move it upward.
- Connect the power supply cable.

The specification of the power supply cable must be as follows:

- Cable size depends on the capacity of external heater. Refer to below table.

| EXTERNAL HEATER Capacity a [kW] | Cable size |
|------------------------------------|-----------------------------|
| $a \leq 12\text{kW}$ | 5 x min 2.5 mm ² |
| $12\text{kW} < a \leq 15\text{kW}$ | 5 x min 4.0 mm ² |
| $15\text{kW} < a \leq 18\text{kW}$ | 5 x min 6.0 mm ² |

- Cable type: 60245 IEC 57 or heavier, with an approved polychloroprene sheath.
- The earth wire must be longer than other wires.
- The specification of the isolating device (disconnecting means) and RCD must be as follows:
- Its rated current depends on the capacity of external heater. Refer to below table.

| EXTERNAL HEATER Capacity a [kW] | Isolating device |
|------------------------------------|------------------|
| $a \leq 9\text{kW}$ | 20 A |
| $9\text{kW} < a \leq 18\text{kW}$ | 40 A |

- Recommended RCD: 30mA, 4P, type A
 - The isolating device must be connected to the power supply cable.
 - The isolating device must have a contact gap of at least 3.0 mm.
- The method of wiring a cable is shown below.
Go through the cable from the left squared bushing hole.

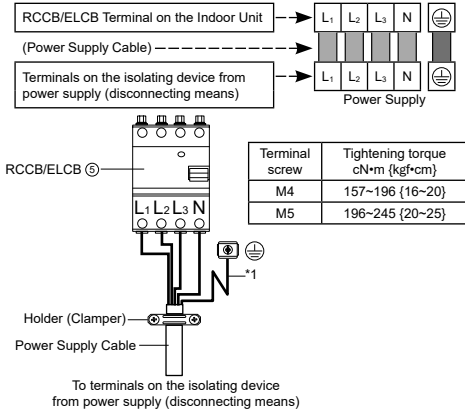

- Connect the ID-OD communication cable.
- The specification of the ID-OD communication cable must be as follows:

- Cable size: 2 x min 0.75 mm²
- Cable type: 60245 IEC 57 or heavier, with a double-insulated approved polychloroprene sheath.

The method of wiring a cable is shown below.

Go through the cable from the left squared bushing hole.

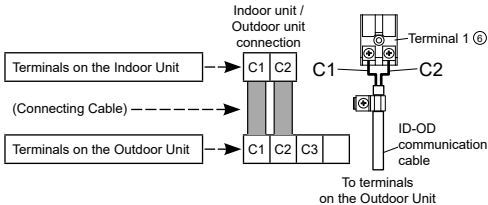

- Assemble the terminal cover.
Reverse step 1.

| | |
|---------------------------------|-------------|
| Tightening torque cN·m {kgf·cm} | 98.1 {10.2} |
|---------------------------------|-------------|

Compliance with IEC/EN 61000-3-2, 3, 11, 12

- 3 kW back up heater per phase and below: The power supply of this Indoor Unit complies with IEC/EN 61000-3-2 and IEC/EN 61000-3-3. It can be connected to the current supply network.
- More than 3 kW back up heater per phase: The power supply of this Indoor Unit complies with IEC/EN 61000-3-12 and IEC/EN 61000-3-11. It must be connected to a suitable supply network with a maximum impedance of $Z_{max} = 0.4037 \text{ Ohm}$. Please liaise with the supply authority to ensure that the maximum impedance of the supply network is sufficient for the installation of the equipment.

EXTERNAL HEATER

External heater can be used as an In-line heater or a buffer tank heater.

- Connect a heater of 18kW (6kW x 3) or less.
- Each heater shall be equipped with an 85°C OLP that can directly turn OFF the power supply. The OLP shall be non-automatic return type.
- The external heater shall be equipped with an 85°C OLP for signal line. The OLP can be either automatic or non-automatic return type.
- Using it as an In-line heater, be sure to install Optional outlet water sensor (PAW-A2W-TSBH) at the heater outlet.
- Using it as a buffer tank heater, be sure to install Optional Buffer tank sensor (PAW-A2W-TSBU).
- Ground the In-line heater body or buffer tank body in case of electrical leakage. (See illustration below)

⚠ WARNING

Incorrect electrical work may result in electric shock or fire. Please follow this installation manual.

How to connect to the main circulation circuit as an In-line heater

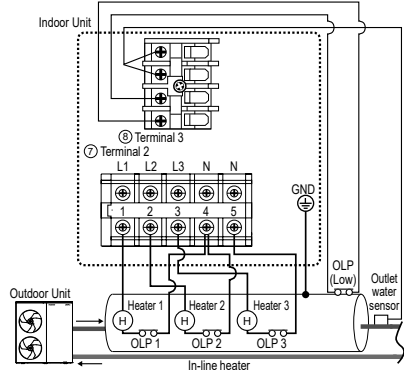

How to connect to the buffer tank as a buffer tank heater

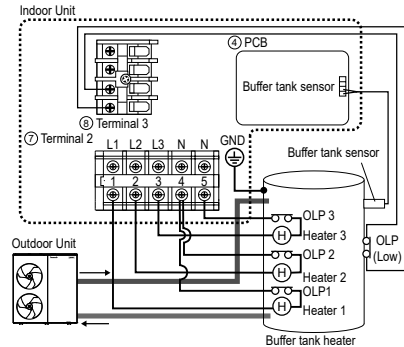

The connecting cable between the external heater (in-line heater or buffer tank heater) and the Indoor Unit should be a double-insulated approved polychloroprene sheathed cord with type designation 60245 IEC 57 or heavier.
Cable size depends on the capacity of external heater.
Refer to below table.

| EXTERNAL HEATER Capacity a [kW] | Cable size | Maximum cable length |
|------------------------------------|-----------------------------|----------------------|
| $a \leq 9\text{kW}$ | 1.5 mm ² or more | 30m |
| $9\text{kW} < a \leq 12\text{kW}$ | 2.5 mm ² or more | |
| $12\text{kW} < a \leq 15\text{kW}$ | 4.0 mm ² or more | |
| $15\text{kW} < a \leq 18\text{kW}$ | 6.0 mm ² or more | |

Maximum cable length of OLP for signal and outlet water sensor: 30m

The specification of the OLP for signal cable must be as follows:

- Cable size: 2 x 2.0 mm²
- Cable type: Double insulation layer of PVC-sheathed or rubber-sheathed cable

The tightening torque for the terminals are as shown in the table below.

| Terminal screw | Tightening torque cN·m {kgf·cm} |
|----------------|---------------------------------|
| M4 | 157~196 {16~20} |
| M5 | 196~245 {20~25} |

- The heater capacity is designed to be 6kW per element.
- For example, if the heater specification is 1kW or 2kW, the display will be worse than the actual COP. (2kW is 1/3 COP of 6kW)

Note: The data calculated by Energy Monitor or COP may be different from the actual value if the capacity is different from 6kW.

WIRE STRIPPING AND CONNECTING REQUIREMENT

| Terminal size | ∅ d [mm] | A [mm] |
|---------------|-------------|--------------|
| M4 | 4.2 or more | 10.0 or less |
| M5 | 5.2 or more | 12.5 or less |

Connecting terminal

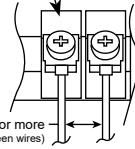

Wire stripping and Crimping a ring terminal onto wire

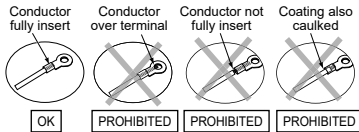

Cable arrangement

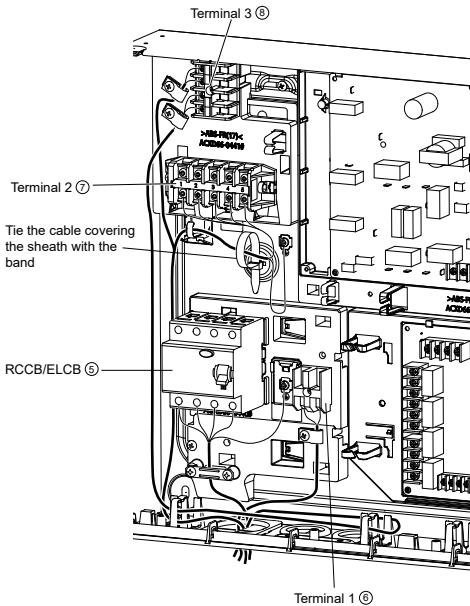

4 CONNECT TO EXTERNAL DEVICE (OPTIONAL)



WARNING

This section is for authorized and licensed electrician only. Work behind the front cover ① secured by screws must only be carried out under the supervision of a qualified contractor, installation engineer, or service person.

Cable specification

- All connections shall be followed the local national wiring standard.
 - It is strongly recommended to use manufacturer-recommended parts or accessories for installation.
 - Connection to PCB ④.
- 2-way valve shall be spring and electronic type. Refer to "Field Supply Accessories" table for details. Valve cable shall be 3 x min 1.5 mm² of type designation 60245 IEC 57 or heavier, or similarly double insulation sheathed cable.
 - *Note: - It shall be CE marking compliance component.
 - Maximum load for the valve is 12VA.
 - 3-way valve shall be spring and electronic type. Valve cable shall be 3 x min 1.5 mm² of type designation 60245 IEC 57 or heavier, or similarly double insulation sheathed cable.
 - *Note: - It shall be CE marking compliance component.
 - It shall be directed to heating mode when it is OFF.
 - Maximum load for the valve is 12VA.
 - Room thermostat zone 1 cable must be 4 or 3 x min 0.5 mm² of type designation 60245 IEC 57 or heavier, or similarly double insulation sheathed cable.
 - Maximum output power of booster heater shall be 3 kW. Booster heater cable must be 3 x min 1.5 mm² of type designation 60245 IEC 57 or heavier.
 - Extra pump cable shall be 2 x min 1.5 mm² of type designation 60245 IEC 57 or heavier.
 - Boiler contact cable/ defrost signal cable shall be 2 x min 0.5 mm² of type designation 60245 IEC 57 or heavier.
 - External control shall be connected to 1-pole switch with min 3.0 mm contact gap. Its cable must be 2 x min 0.5 mm² double insulation layer of PVC-sheathed or rubber-sheathed cable.
 - *Note: - The switch shall be CE compliance component.
 - Maximum operating current shall be 3Arms.
 - Tank sensor shall be resistance type. See the graph below for the characteristic and details of sensor. Its cable shall be 2 x min 0.3 mm² double insulation layer (with insulation strength of min 30V) of PVC-sheathed or rubber-sheathed cable.

Tank Sensor Resistance Vs Temperature

Tank sensor characteristic
 - Room sensor zone 1 cable shall be 2 x min 0.3 mm² double insulation layer of PVC-sheathed or rubber-sheathed cable.
 - Outdoor air sensor cable shall be 2 x min 0.3 mm² double insulation layer of PVC-sheathed or rubber-sheathed cable.
 - OLP cable must be 2 x min 0.5 mm² double insulation layer of PVC-sheathed or rubber-sheathed cable.
 - Buffer tank sensor cable shall be 2 x min 0.3 mm² double insulation layer of PVC-sheathed or rubber-sheathed cable.

- Connection to Optional PCB ⑤

1. Before connecting the cables to Optional PCB, remove the network adaptor holder ② (Refer to the installation manual of CZ-NS7P for details).
2. Pump zone 1 and zone 2 cable shall be 2 x min 1.5 mm² of type designation 60245 IEC 57 or heavier.
3. Solar pump cable shall be 2 x min 1.5 mm² of type designation 60245 IEC 57 or heavier.
4. Pool pump cable shall be 2 x min 1.5 mm² of type designation 60245 IEC 57 or heavier.
5. Room thermostat zone 2 cable shall be 4 x min 0.5 mm² of type designation 60245 IEC 57 or heavier.
6. Mixing valve zone 1 and zone 2 cable shall be 3 x min 1.5 mm² of type designation 60245 IEC 57 or heavier.
7. Room sensor zone 1 and zone 2 cable shall be 2 x min 0.3 mm² double insulation layer (with insulation strength of minimum 30V) of PVC-sheathed or rubber-sheathed cable.
8. Pool water sensor and solar sensor cable shall be 2 x min 0.3 mm² double insulation layer (with insulation strength of minimum 30V) of PVC-sheathed or rubber-sheathed cable.
9. Water sensor zone 1 and zone 2 cable shall be 2 x min 0.3 mm² double insulation layer of PVC-sheathed or rubber-sheathed cable.
10. Demand signal cable shall be 2 x min 0.3 mm² double insulation layer of PVC-sheathed or rubber-sheathed cable.
11. SG signal cable shall be 3 x min 0.3 mm² double insulation layer of PVC-sheathed or rubber-sheathed cable.
12. Heat/Cool switch cable shall be 2 x min 0.3 mm² double insulation layer of PVC-sheathed or rubber-sheathed cable.
13. External compressor switch cable shall be 2 x min 0.3 mm² double insulation layer of PVC-sheathed or rubber-sheathed cable.

- How to access the Optional PCB ⑤

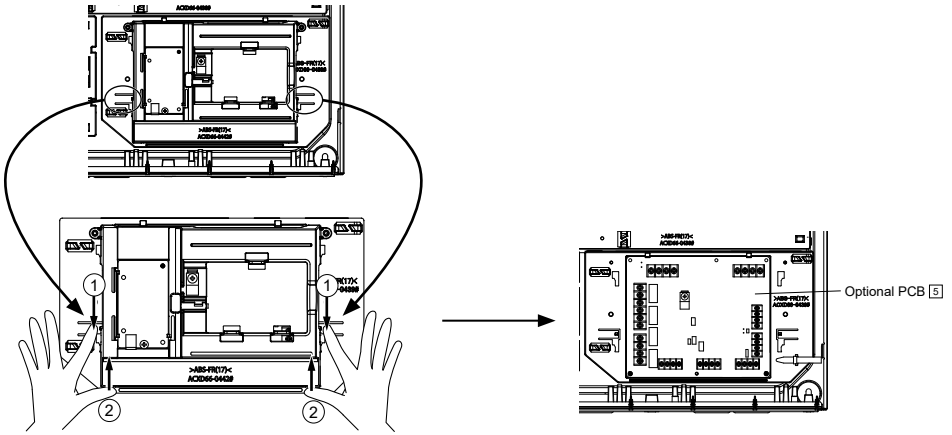

Cable arrangement

How to guide the optional cables and power supply cord connecting
(view without internal wiring)

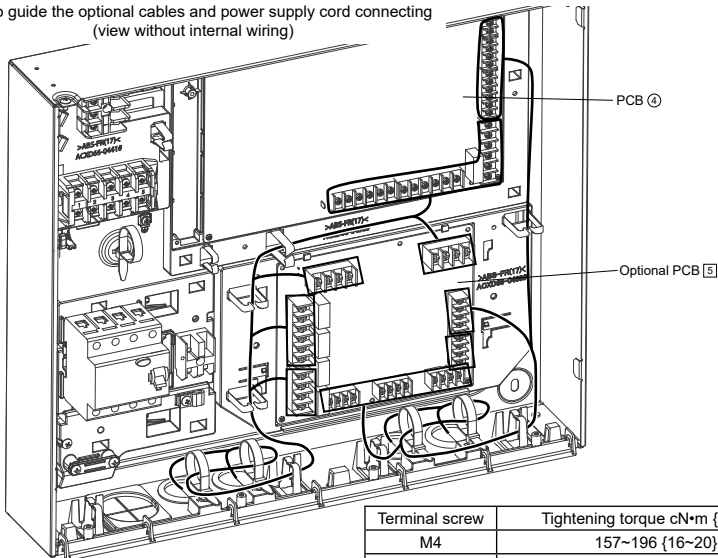

| Terminal screw | Tightening torque cN·m (kgf·cm) |
|----------------|---------------------------------|
| M4 | 157~196 (16~20) |
| M5 | 196~245 (20~25) |

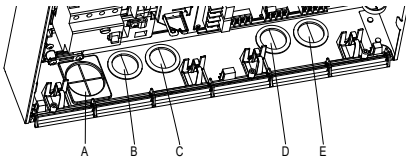

■ Bushing hole A is used for power supply cable (including external heater power supply), outlet water sensor cable, OLP for signal line cable and ID-OD communication cable

■ Bushing hole B and C are used for

- Pump zone 1 cable
- Pump zone 2 cable
- Solar pump cable
- Pool pump cable
- Room thermostat zone 1 cable
- Room thermostat zone 2 cable
- Booster heater cable
- Mixing valve zone 1 cable
- Mixing valve zone 2 cable
- 2-way valve cable
- 3-way valve cable
- Extra pump cable
- Boiler contact cable
- Defrost signal cable

■ Bushing hole D and E are used for

- External control cable
- Outdoor air sensor cable
- Remote controller cable
- Room sensor zone 1 cable
- Room sensor zone 2 cable
- Buffer tank sensor cable
- Pool water sensor cable
- OLP for booster heater cable
- Water sensor zone 1 cable
- Water sensor zone 2 cable
- Demand signal cable
- Solar sensor cable
- SG signal cable
- Heat/Cool switch cable
- External compressor switch cable

■ Ensure all sensor cables are not in touching the front panel.

■ Once all wiring work is done, tie the cable with the banding strap (field supply).

Cable length

When connecting cables between the Indoor Unit and external devices, the length of the cables must not exceed the maximum length as shown in the table below.

| External device | Maximum cable length [m] |
|--|--------------------------|
| 2-way valve, 3-way valve, Mixing valve, Room Thermostat, Booster heater, Extra pump, Solar pump, Pool pump, Zone pump, Boiler contact/Defrost signal, External control, Demand signal, SG signal, Heat/Cool switch, External compressor switch | 50 |
| Room sensor, Outdoor air sensor, Buffer tank sensor, Pool water sensor, Solar sensor, Zone water sensor | 30 |

Connection of PCB

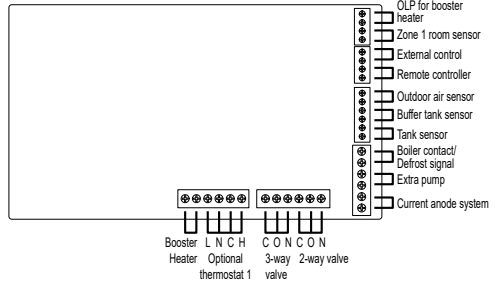

■ Signal inputs

| | |
|------------------------|---|
| Optional thermostat | L N=AC230V, Heat, Cool=Thermostat heat, Cool terminal |
| OLP for booster heater | Dry contact Vcc-Bit1, Vcc-Bit2 open/short (System setup necessary) It is connected to the safety device (OLP) of DHW tank. |
| External control | Dry contact Open=not operate, Short=operate (System setup necessary) Able to turn ON/OFF the operation by external switch |
| Remote controller | Connected (Use 2 cores wire for relocation and extension. Total cable length shall be 50m or less.) |

■ Thermistor inputs

| | |
|--------------------|------------------------------|
| Zone 1 room sensor | PAW-A2W-TSRT |
| Outdoor air sensor | PAW-A2W-TSOD |
| Tank sensor | Use Panasonic specified part |
| Buffer tank sensor | PAW-A2W-TSBU |

■ Outputs

| | |
|-------------------------------|---|
| 3-way valve | AC230V N=Neutral Open, Close=direction (For circuit switching when connected to DHW tank) |
| 2-way valve | AC230V N=Neutral Open, Close (Prevent water circuit pass through during cooling mode) |
| Extra pump | AC230V (Used when Indoor Unit pump capacity is insufficient) |
| Booster heater | AC230V (Used when using booster heater in DHW tank) |
| Boiler contact/Defrost signal | Dry contact (System setup necessary) |

Connection of Optional PCB (CZ-NS7P)

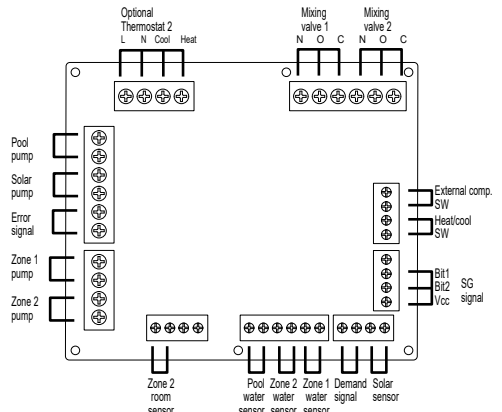

■ Signal inputs

| | | |
|---------------------|---|--|
| Optional Thermostat | L N =AC230V, Heat, Cool=Thermostat heat, Cool terminal | |
| SG signal | Dry contact Vcc-Bit1, Vcc-Bit2 open/short (System setup necessary) Switching SW (Connect to the 2 contacts controller) | |
| Heat/Cool SW | Dry contact Open=Heat, Short=Cool (System setup necessary) | |
| External comp. SW | Dry contact Open=Comp.OFF, Short=Comp.ON (System setup necessary) | |
| Demand signal | DC 0~10V (System setup necessary) Connect to the DC 0~10V controller. | |

■ Thermistor inputs

| | |
|-------------------|--------------|
| Zone room sensor | PAW-A2W-TSRT |
| Pool water sensor | PAW-A2W-TSHC |
| Zone water sensor | PAW-A2W-TSHC |
| Solar sensor | PAW-A2W-TSSO |

■ Outputs

| | | |
|--------------|--|--------------------|
| Mixing valve | AC230V N=Neutral Open, Close=mixture direction Operating time: 30s~120s | AC230V, 6 VA |
| Pool pump | AC230V | AC230V, 0.6 A max. |
| Solar pump | AC230V | AC230V, 0.6 A max. |
| Zone pump | AC230V | AC230V, 0.6 A max. |

Recommended External Device Specification

This section explains about the external devices (optional) recommended by Panasonic. Always ensure to use the correct external device during system installation.

• Optional sensor.

1. Buffer tank sensor: PAW-A2W-TSBU

Use it to measure the buffer tank temperature.
Insert the sensor into the sensor pocket on the tank.

Unit in mm

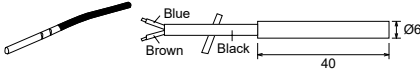

2. Zone water sensor: PAW-A2W-TSHC

Use it to measure the control zone temperature.
Mount it on the water piping by using the stainless steel metal strap and contact paste (both are included).

Unit in mm

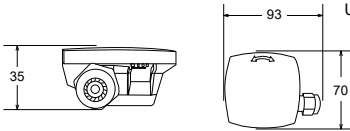

3. Outdoor air sensor: PAW-A2W-TSOD

If the installation location of the outdoor unit is exposed to direct sunlight, the outdoor air temperature sensor will be unable to measure the actual outdoor ambient temperature correctly.

Unit in mm

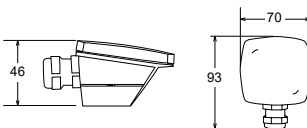

4. Room sensor: PAW-A2W-TSRT

Install the room temperature sensor to the room where the temperature control is required.

Unit in mm

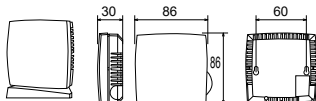

5. Solar sensor: PAW-A2W-TSSO

Use it to measure the solar panel temperature.
Insert the sensor into the sensor pocket and paste it on the solar panel surface.

Unit in mm

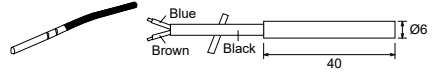

See the table below for the characteristic of the sensors (No. 1 to 5).

| Temperature (°C) | Resistance value (kΩ) | Temperature (°C) | Resistance value (kΩ) |
|------------------|-----------------------|------------------|-----------------------|
| 30 | 5.326 | 150 | 0.147 |
| 25 | 6.523 | 140 | 0.186 |
| 20 | 8.044 | 130 | 0.236 |
| 15 | 9.980 | 120 | 0.302 |
| 10 | 12.443 | 110 | 0.390 |
| 5 | 15.604 | 100 | 0.511 |
| 0 | 19.70 | 90 | 0.686 |
| -5 | 25.05 | 80 | 0.932 |
| -10 | 32.10 | 70 | 1.279 |
| -15 | 41.45 | 65 | 1.504 |
| -20 | 53.92 | 60 | 1.777 |
| -25 | 70.53 | 55 | 2.106 |
| -30 | 93.05 | 50 | 2.508 |
| -35 | 124.24 | 45 | 3.003 |
| -40 | 167.82 | 40 | 3.615 |
| | | 35 | 4.375 |

6. Outlet water sensor: PAW-A2W-TSBH

Use it to detect the water temperature of the In-line heater outlet water.

Mount it on the water piping by using the stainless steel metal strap and contact paste (both items are included).

Unit in mm

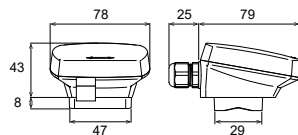

See the table below for the characteristic of the outlet water sensor (No. 6).

| Temperature (°C) | Resistance value (kΩ) | Temperature (°C) | Resistance value (kΩ) |
|------------------|-----------------------|------------------|-----------------------|
| 30 | 16.07 | 150 | 0.40 |
| 25 | 20.00 | 140 | 0.50 |
| 20 | 25.07 | 130 | 0.63 |
| 15 | 31.67 | 120 | 0.81 |
| 10 | 40.35 | 110 | 1.06 |
| 5 | 51.85 | 100 | 1.40 |
| 0 | 67.24 | 90 | 1.87 |
| -5 | 88.05 | 80 | 2.54 |
| -10 | 116.49 | 70 | 3.52 |
| -15 | 155.80 | 65 | 4.17 |
| -20 | 210.77 | 60 | 4.97 |
| -25 | 288.63 | 55 | 5.96 |
| -30 | 400.41 | 50 | 7.18 |
| -35 | 563.15 | 45 | 8.70 |
| -40 | 803.72 | 40 | 10.60 |
| | | 35 | 13.01 |

Network Adaptor 2 Installation

1. Insert a flathead screwdriver into the slot on the network adaptor and remove the cover.
2. Connect cable coming out from the left side of the network adaptor holder to the connector inside the network adaptor.

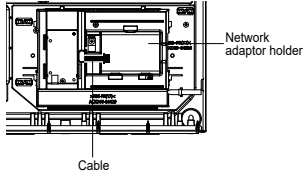
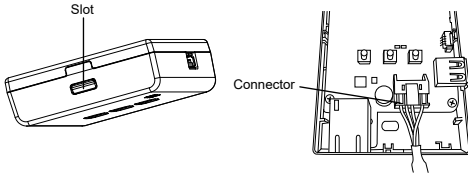

3. Pull the CN-CNT cable through the hole in the bottom of the network adaptor and re-attach the front cover to the back cover.

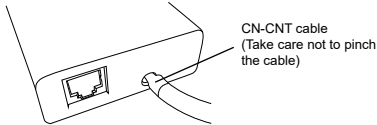

4. Fix the network adaptor 2 to network adaptor holder. Guide the cable as shown in the diagram so that external forces cannot act on the connector in the network adaptor.

Connection of M-Bus, Modbus or KNX

When connecting devices such as Panasonic A2W compatible M-Bus or Modbus, it is necessary to change the connection position of the network adaptor on the PCB.

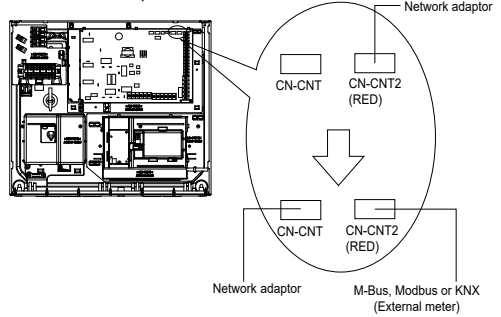

1. Replace the lead wire connector of the network adaptor connected to CN-CNT2 with CN-CNT.
2. Insert the M-Bus or Modbus, etc. lead wire connector into CN-CNT2.

When connecting Optional PCB to devices such as M-Bus or Modbus, it is necessary to change the connection position of the network adaptor on the PCB.

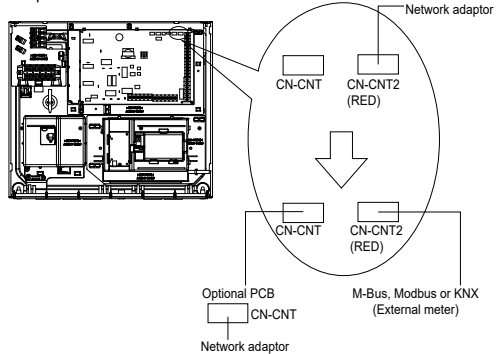

1. Insert the Optional PCB lead wire connector into CN-CNT.
2. Replace the lead wire connector of the network adaptor connected to CN-CNT2 with CN-CNT on Optional PCB.
3. Insert the M-Bus or Modbus, etc. lead wire connector into CN-CNT2.

5 INSTALL REMOTE CONTROLLER AS ROOM THERMOSTAT

⚠ WARNING

This section is for authorized and licensed electrician only. Work behind the front cover ① secured by screws must only be carried out under the supervision of a qualified contractor, installation engineer, or service person.

- Remote controller ③ mounted to the indoor unit can be moved to the room and serve as a Room Thermostat.

INSTALLATION LOCATION

- Install at the height of 1 to 1.5 m from the floor where average room temperature can be detected properly.
- Install vertically against the wall.
- Avoid the following locations for installation.
 - Location exposed to direct sunlight or direct air.
 - In the shadow or backside of objects deviated from the room airflow.
 - Location where condensation occurs (The remote controller is not moisture proof or drip proof.)
 - Location near heat source.
 - Uneven surface.
- Keep distance of 1 m or more from the TV, radio and PC. (Cause of fuzzy image or noise)

Remote Controller Wiring

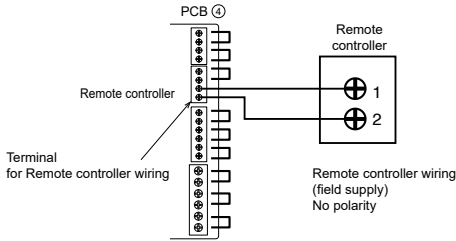

- Remote controller cable shall be 2 x min 0.3 mm², of double insulation PVC-sheathed or rubber sheathed cable. Total cable length shall be 50 m or less.
- Do not connect cables to other terminals of Indoor Unit (e.g. power source wiring terminal); malfunction be caused.
- Do not bundle together with the power supply cable or store in the same metal tube; operation error may be caused.

Remove the remote controller from the Indoor Unit

- Remove both left and right decoration panel (⑩ and ⑪) from the front cover ① while gently pushing them from the behind.

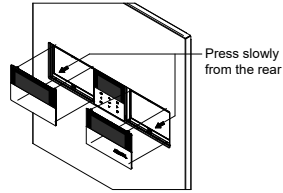

- Remove the 4 screws and take out the holder with remote controller ③.

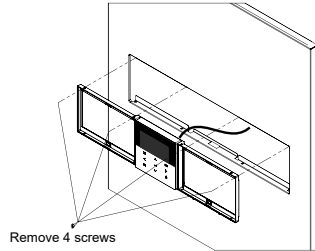

- Remove the body from the base.

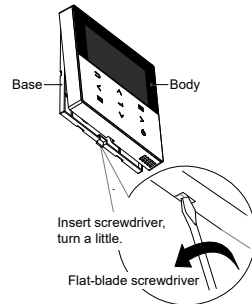

- Remove the cable between remote controller ③ and Indoor Unit terminal.

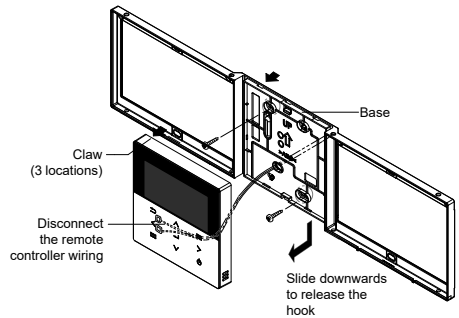

Mounting the remote controller

For exposure type

Preparation: Drill 2 holes for screws with a screwdriver.

- 1 Mount the base on the wall.
 - Thread the wire through the hole in the centre of the base.
- 2 Connect the remote control wiring
 - Route the wires along the groove in the case.
- 3 Attach the body.
 - Align the claws of the body and then the claws of the base.

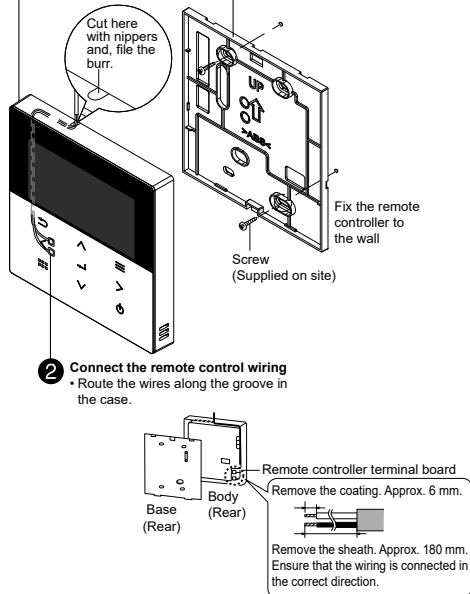

For embedded type

Preparation: Drill 2 holes for screws with a screwdriver.

- 1 Mount the base on the wall.
 - Thread the wire through the hole in the centre of the base.
- 2 Connect the remote control wiring
 - Ensure that the wire is not congested.
- 3 Attach the body.
 - Align the claws of the body and then the claws of the base.

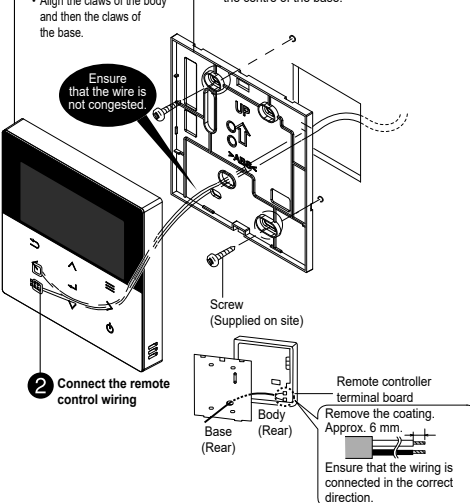

Replace The Remote Controller Cover

- Replace the existing remote controller with remote controller Case [3] to close the hole left after removing it.
 1. Refer to Section "Remove the remote controller From Indoor Unit".
 2. Remove the top case from the bottom case of remote controller Case [3].

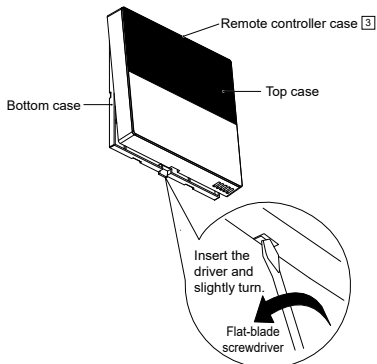

3. Reverse the steps 1 to 4 of section "Remove The remote controller From Indoor Unit" to fix remote controller Case [3] to Indoor Unit.

6 CHECK RCCB/ELCB

1. Ensure the RCCB/ELCB set to "ON" condition before check RCCB/ELCB.
2. Turn ON the power supply to the Indoor Unit. This check can only be done when power is supplied to the Indoor Unit.

⚠ WARNING

Be careful not to touch parts other than RCCB/ELCB test button when the power is supplied to Indoor Unit. Otherwise, electrical shock may be caused. Before obtaining access to terminals, all supply circuits must be disconnected.

3. Push the "TEST" button on the RCCB/ELCB. The lever would turn down, if it works properly.
4. Contact authorized dealer if the RCCB/ELCB malfunction.
5. Turn OFF the power supply to the Indoor Unit.
6. If RCCB/ELCB functions normal, set the lever to "ON" again.

7 CLOSE FRONT COVER

Gently close the front cover and fix with 2 screws.

Tightening torque cN·m {kgf·cm}

147.1~245.2 {15~25}

8 CHECK WATER CIRCUIT

CHECK WATER PRESSURE * (0.50 bar = 0.05 MPa)

Water pressure must not be lower than 0.50 bar. (Check the water pressure by the remote controller.) If it is lower, fill Space Heating/Cooling pipes with water through the tube connector on the outdoor unit.

Icon flashes if dropped below "0.50 bar"

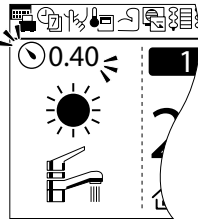

CHECK PRESSURE RELIEF VALVE *Pressure relief valve is located on outdoor unit.

1. Pull the lever in the horizontal direction and confirm that the pressure relief valve works properly.
2. Release the lever when water comes out of the drain pipe of the pressure relief valve. While the air continues to come out of the drain pipe, keep raising the lever to completely discharge the air.
3. Confirm that the water from the drain pipe stops.
4. If water is leaking, pull the lever several times and return it to make sure the water stops.
5. If water keeps coming out of the drain, turn OFF the system and contact your local authorized dealer.

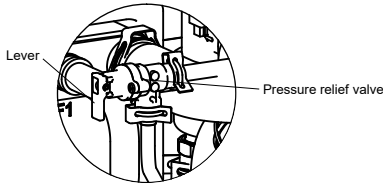

CHECK AIR ACCUMULATION

- Open the air vent plugs on the heating panel, fan convactor, etc., and remove the air accumulated in the equipment and piping.

EXPANSION VESSEL PRE PRESSURE CHECKING

- The system where the Indoor Unit is installed is equipped with an expansion vessel with the capacity of 10 L and the initial pressure of 1 bar.
- The total volume of water in the system should not exceed 200 L.
- If the total water volume exceeds 200 L, add an expansion vessel. (Supplied on site)
- The installed height difference of the water circuit of the system should not exceed 30 m. (Extra pump may be required).

*In case of 30 m, set the pressure in the circulation circuit to 0.5~1.0 bar. Higher than 1.0 bar may cause water leakage due to component breakage.

9 TEST RUN

1. Check the items below before the test run.
 - a) Pipework are properly done.
 - b) Electric cable connecting work are properly done.
 - c) Water circuit unit is filled up with water and trapped air is released.
 - d) Turn ON the power supply after filling the indoor until full.
2. Turn ON the power supply for the Indoor, and RCCB/ELCB in the Indoor Unit. Then, refer to the Operation Instruction for operation of remote controller ③.

Note:

During winter, turn ON the power supply and standby the unit for at least 15 minutes before test run. To allow sufficient time to warm up refrigerant and prevent wrong error code judgement.

3. For normal operation, the water pressure reading should be in between 0.50 bar and 4.00 bar (0.05 MPa and 0.4 MPa). If not, adjust the speed of the water pump to bring it into the aforementioned pressure operating range. If this procedure does not solve the problem, contact a local authorized dealer.
4. After test run, clean the magnetic water filter set with reference to "Maintenance for magnetic water filter" in the Installation Manual of the AIR-TO-WATER HEAT PUMP OUTDOOR UNIT and reinstall it. After the cleaning is finished.

CHECK WATER FLOW OF THE WATER CIRCUIT

Select Installer setup → Service setup → Pump maximum speed → Air purge.

Confirm that the maximum water flow rate is not less than 25 l/min when the main pump is in operation.

- * Water flow can be checked in Service setup (Pump maximum speed)

[Heating operation at low water temperature with lower flow rate may cause "H75" during defrost process.]

- * If there is no water flow or H62 is displayed, stop pump operation and release the air (See "CHECK AIR ACCUMULATION").

10 MAINTENANCE

- To ensure the safety and optimum performance of the indoor unit, seasonal inspections of the indoor unit and functional checks of RCCB/ELCB, field wiring and pipe should be carried out on a regular basis. This maintenance and scheduled inspection should be carried out by authorized dealer.
- Regular maintenance of the expansion vessel (at least once a year) is recommended and should be performed by authorized dealer. First, make sure that the expansion or pressure tank is completely drained of water, that the system is switched off, and that there are no live electrical components. If you need to reset the preload pressure, set 1bar.

CHECK ITEMS

- Is there any water leakage at water piping connections?
- Has the heat insulation been carried out at water piping connection?
- Is water pressure higher than 0.5 bar?
- Is the water drainage work properly done?
- Is the power supply voltage within the rated voltage range?
- Are the cables being fixed to RCCB/ELCB, terminal and PCB firmly?
- Are the cables being clamped firmly by holder (clamper)?
- Is the earth wire connection properly done?
- Is the RCCB/ELCB operation normal?
- Is the remote controller ③ LCD operation normal?
- Is there any abnormal sound?
- Is the heating operation normal?

APPENDIX

1 Variation of system

This section introduces some variation of systems using Air-To-Water Heat pump and actual setting method.

For this model, the Zone 1 external room thermistor and Zone 1 external room thermostat must be always connected to the main room board, irrespective of whether they are connected to a board (CZ-NS7P) sold separately.

1-1. Introduce applications related to temperature setting.

Temperature setting variation for heating

1. Remote controller

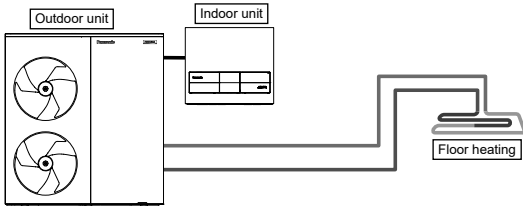

- Connect floor heating and radiators directly to the outdoor unit.
- The remote controller is located on the indoor unit.
- This is the simplest system.

Setting of remote controller

Installer setup
System setup
Optional PCB connectivity - No
Zone & Sensor:
Water temperature

2. Room thermostat

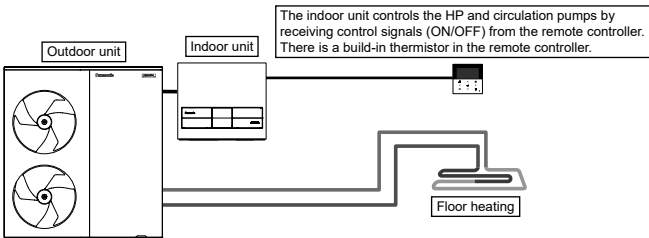

Connect floor heating and radiators directly to the outdoor unit.
Remove the remote controller from the indoor unit and install it in the room where the floor heating is installed.
This is an application that uses remote controller.

Refer to **5 INSTALL REMOTE CONTROLLER AS ROOM THERMOSTAT (OPTIONAL)**.

Setting of remote controller

Installer setup
System setup
Optional PCB connectivity - No
Zone & Sensor:
Room Thermostat
Internal

3. External room thermostat

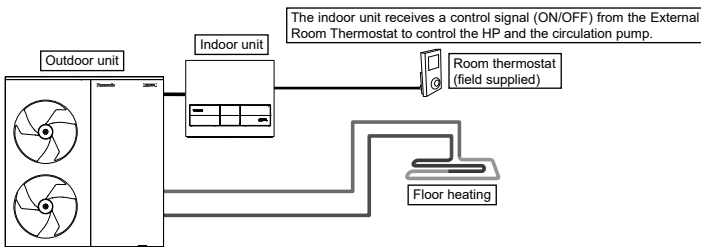

Connect floor heating and radiators directly to the outdoor unit.
The remote controller is located on the indoor unit.
Install separate External Room Thermostat (field supply) in the room where floor heating is installed.
This is an application that uses External Room Thermostat.

Setting of remote controller

Installer setup
System setup
Optional PCB connectivity - No
Zone & Sensor:
Room Thermostat
(External)

4. Room thermistor

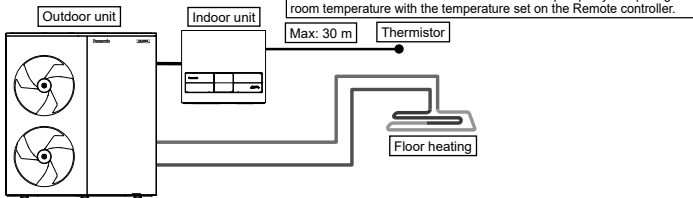

Setting of remote controller

Installer setup
 System setup
 Optional PCB connectivity - No
 Zone & Sensor:
 Room thermistor

Connect floor heating or radiator directly to the outdoor unit.
 The remote controller is located on the indoor unit.
 An external room thermistor (specified by Panasonic) is installed in the room where the floor heating is installed.
 This is an application that uses an external room thermistor.

There are two ways of setting the circulating water temperature.
 Direct: Sets the circulating water temperature directly (fixed value).
 Correction curve: sets the circulating water temperature according to the outside temperature.
 In case of Room thermistor, the compensation curve is shifted according to the thermo ON/OFF situation.

- (Example) If room temperature increasing speed is:
 Very slow → Shift the compensation curve upwards
 Very fast → Shift compensation curve downwards

Examples of installations

Floor heating 1 + Floor heating 2

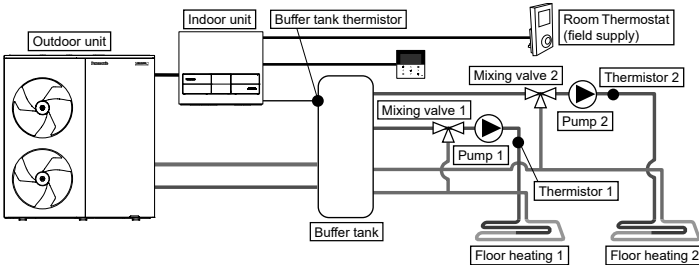

Setting of remote controller

Installer setup
 System setup
 Optional PCB connectivity - Yes
 Zone & Sensor - 2-zone system
 Zone 1: Sensor
 Room thermostat
 Internal
 Zone 2: Sensor
 Room
 Room thermostat
 (External)

Connect Floor heating to the 2 circuits via buffer tank as shown in the figure.
 Install mixing valves, pumps and thermistors (specified by Panasonic) on both circuits.
 Remove the remote controller from the indoor unit and attach it to either circuit to use as a Room Thermostat.
 Install an external Room Thermostat (field-supply) on another circuit.
 Both circuits can set the circulating water temperature independently.
 Install the buffer tank thermistor on the buffer tank.
 The buffer tank connection settings and the ΔT temperature settings for heating operation are required separately.
 This system requires an Optional PCB (CZ-NS7P).
 Note: Buffer tank thermistor must be connected to PCB ④.

Floor heating + Radiator

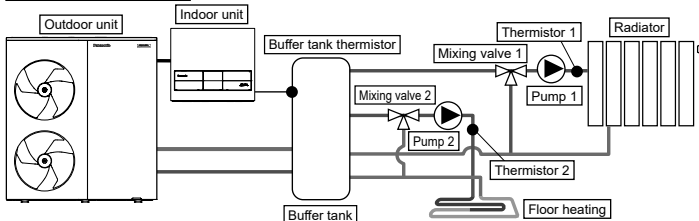

Setting of remote controller

Installer setup
 System setup
 Optional PCB connectivity - Yes
 Zone & Sensor - 2-zone system
 Zone 1: Sensor
 Water temperature
 Zone 2: Sensor
 Room
 Water temperature

Connect Floor heating and radiators to the 2 circuits via buffer tank, as shown in the figure above. Install pumps and thermistors (specified by Panasonic) on both circuits.
 Install a mixing valve in the circuit with lower temperature among the 2 circuits. (Generally, where floor heating and radiator circuits are installed in 2 zones, install mixing valve in the floor heating circuit.)
 The remote controller is located on the indoor unit.
 The temperature setting selects the circulating water temperature for both circuits. Both circuits can be set the circulating water temperature independently.
 Install thermistor on the buffer tank. The buffer tank connection settings and the ΔT temperature settings for heating operation are required separately.
 This system requires the Optional PCB (CZ-NS7P). Note: if there is no mixing valve on the secondary side, the circulating water temperature may be higher than the set temperature.
 Note: Buffer tank thermistor must be connected to PCB ④.

Floor heating + Swimming pool

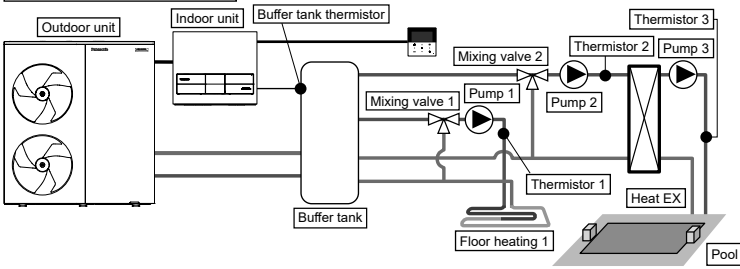

Setting of remote controller

Installer setup
System setup
Optional PCB connectivity - Yes

Zone & Sensor: - 2-zone system
Zone 1: Sensor
Room thermostat
Internal

Zone 2
Swimming pool
 ΔT

Connect floor heating and swimming pool to the 2 circuits via buffer tank, as shown in the figure above.

Install mixing valves, pumps and thermistors (specified by Panasonic) on both circuits.

Additional pool heat exchanger, pool pumps and pool sensor are installed in the pool circuit.

Remove the remote controller from the indoor unit and install it in the room where the floor heating is installed. The floor heating and the pool circulation water temperatures can be set separately.

Install thermistor on the buffer tank.

The buffer tank connection settings and the ΔT temperature settings for heating operation are required separately. This system requires the Optional PCB (CZ-NS7P).

※ Be sure to connect the pool to "Zone 2".

When connected to a swimming pool, operating in 'Cool' will stop the pool operation.

Note: Buffer tank thermistor must be connected to PCB ④.

Swimming pool only

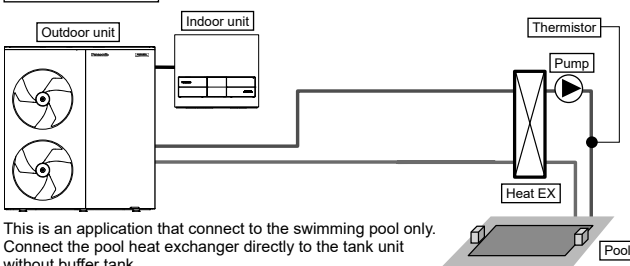

Setting of remote controller

Installer setup
System setup
Optional PCB connectivity - Yes

Zone & Sensor: - 1-zone system
Zone: Swimming pool
 ΔT

This is an application that connect to the swimming pool only.

Connect the pool heat exchanger directly to the tank unit without buffer tank.

Install a pool pump and pool thermistor (specified by Panasonic) at the secondary side of the pool heat exchanger.

The pool temperature can be set with a remote controller.

This system requires the Optional PCB (CZ-NS7P).

The cooling mode cannot be selected for this application. (Not displayed on the remote controller).

Simple 2 zone (Floor heating + Radiators)

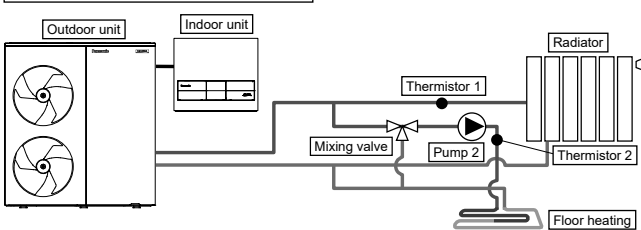

Setting of remote controller

Installer setup
System setup
Optional PCB connectivity - Yes

Zone & Sensor: - 2-zone system
Zone 1: Sensor
Water temperature

Zone 2: Sensor
Room
Water temperature

Operation setup
Heat
 ΔT for heating ON - 1°C

Cool
 ΔT for cooling ON - 1°C

This is an example of simple 2 zone control without buffer tank.

The built-in pump in the Outdoor unit acts as the pump for zone 1.

Install mixing valve, pump and thermistor (specified by Panasonic) at zone 2 circuit.

The temperature in Zone 1 is not adjustable, so always assign the hot side to Zone 1.

To display the temperature of zone 1 on the remote controller, zone 1 thermistor is required.

The circulating water temperature for both circuits can be set independently.

(However, the temperature of high temperature side and low temperature side cannot be reversed.)

This system requires the Optional PCB (CZ-NS7P).

Note:

- Thermistor 1 has no direct influence on the operation. However, if thermistor 1 is not installed, an error will occur.
 - Adjust the flow rate so that zone 1 and zone 2 are balanced. If not correctly adjusted, performance may be affected. (If the pump flow rate in zone 2 is too high, hot water may not flow to zone 1)
- The flow rate can be checked from "Actuator Check" under maintenance menu.

Buffer tank connection

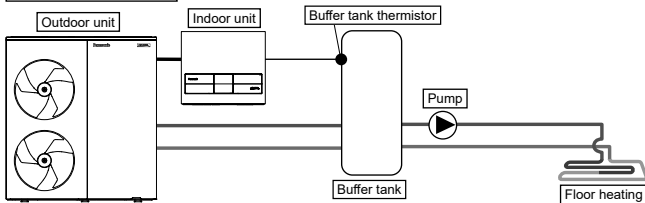

Setting of remote controller

Installer setup
 System setup
 Optional PCB connectivity - No
 Buffer tank connection - Yes
 ΔT for Buffer tank

This is an application that connects the buffer tank to the indoor unit.
 The temperature of the buffer tank is detected by a buffer tank thermistor (specified by Panasonic).
 If Optional PCB is not connected, external pump can be used for circulation in the floor heating circuit.
 Note: Buffer tank thermistor must be connected to PCB ④.

Buffer tank + Solar

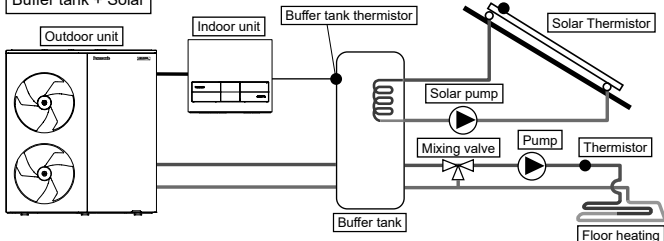

Setting of remote controller

Installer setup
 System setup
 Optional PCB connectivity - Yes
 Buffer tank connection - Yes
 ΔT for Buffer tank
 Solar connection - Yes
 Buffer tank
 ΔT turn ON
 ΔT turn OFF
 Anti freeze
 Hi limit

This is an application that connect the buffer tank unit to the indoor unit and then to the solar water heater to heat the buffer tank.
 The temperature of the buffer tank is detected by a buffer tank thermistor (specified by Panasonic).
 The temperature of the solar panel is detected by a solar thermistor (specified by Panasonic).
 Buffer tanks are stand-alone tanks with built-in solar heat exchange coils.
 During winter season, solar pump for circuit protection will be activated continuously. If you wish not to activate the solar pump operation, use glycol and set the anti-freezing operation start temperature to -20°C.
 Heat accumulation operates automatically by comparing the temperature of tank thermistor and solar thermistor.
 This system requires the Optional PCB (CZ-NS7P).
 Note: Buffer tank thermistor must be connected to PCB ④.

Boiler connection

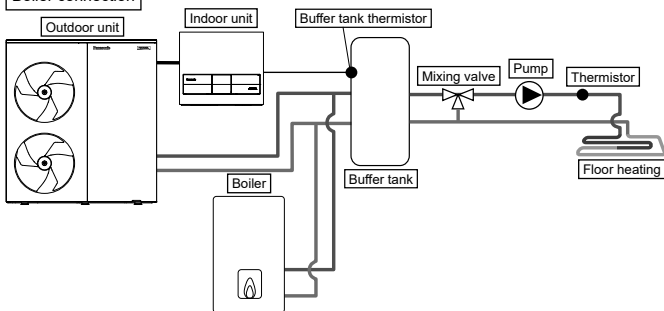

Setting of remote controller

Installer setup
 System setup
 Optional PCB connectivity - Yes
 Bivalent - Yes
 Turn ON: outdoor temp
 Control pattern

This is an application that connects the boiler to the buffer tank, to compensate for insufficient capacity by operate boiler when outdoor temperature drops & heat pump capacity is insufficient.
 Boiler is connected parallel with heat pump and used as heating circuit.
 The boiler output can be controlled either by SG-ready input from a board (sold separately) or by automatic control via three mode selection patterns. (Operation setting of boiler shall be responsible by installer.)
 This system requires the Optional PCB (CZ-NS7P) for SG-ready input control.
 Depending on the settings of the boiler, it is recommended to install buffer tank as temperature of circulating water may get higher. (In particular, if the advanced parallel setting is selected, it must be connected to a buffer tank.)
 Note: Buffer tank thermistor must be connected to PCB ④.

⚠ WARNING

Panasonic is NOT responsible for incorrect or unsafe situation of the boiler system.

⚠ CAUTION

Make sure the boiler and its integration in the system complies with applicable legislation.
 Ensure that the return water temperature from the heating circuit to the indoor unit does not exceed 70°C.
 Boiler is turned off by safety control when the water temperature of the heating circuit exceed 85°C.

2 System Installation

3-1. Remote Controller Outline

The LCD display as shown in this manual are for instructional purpose only, and may differ from the actual unit.

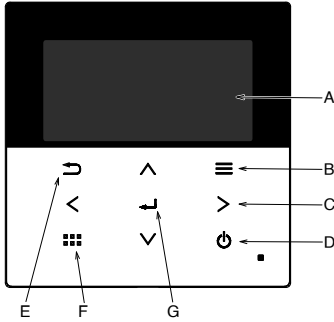

| Name | Function |
|--------------------|---------------------------|
| A: Main screen | Display information |
| B: Menu | Open/Close the main menu |
| C: Triangle (Move) | Select and change item |
| D: Operate | Start/Stop operation |
| E: Back | Back to previous item |
| F: Quick Menu | Open/Close the Quick menu |
| G: Enter | Confirm |

LCD Display
(Actual - Dark background with white icons).

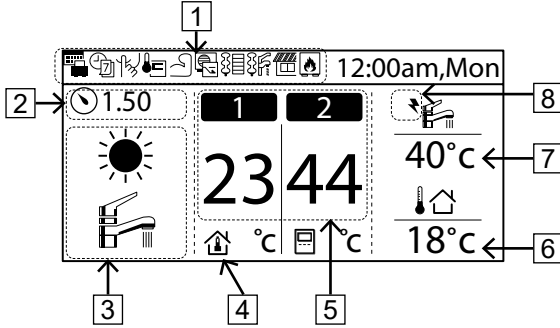

| Name | Function | | | | | | | | | | |
|---|---|--------------|----------------|--------------|------------------|--------------|--------------|-----------------------------------|-------|---------------|--------|
| 1: Function icon | Displays the set functions/status. <table border="0"> <tr> <td> Holiday mode</td> <td> Demand control</td> </tr> <tr> <td> Weekly timer</td> <td> Room heater</td> </tr> <tr> <td> Quiet mode</td> <td> Tank heater</td> </tr> <tr> <td> Remote controller room thermostat</td> <td> Solar</td> </tr> <tr> <td> Powerful mode</td> <td> Boiler</td> </tr> </table> | Holiday mode | Demand control | Weekly timer | Room heater | Quiet mode | Tank heater | Remote controller room thermostat | Solar | Powerful mode | Boiler |
| Holiday mode | Demand control | | | | | | | | | | |
| Weekly timer | Room heater | | | | | | | | | | |
| Quiet mode | Tank heater | | | | | | | | | | |
| Remote controller room thermostat | Solar | | | | | | | | | | |
| Powerful mode | Boiler | | | | | | | | | | |
| 2: Water pressure (circulation circuit) | (1.50) Displays water pressure in bar (blinks when less than 0.5) | | | | | | | | | | |
| 3: Mode | Displays the setting mode and the current mode status. <table border="0"> <tr> <td> Heating</td> <td> Cooling</td> </tr> <tr> <td> Auto</td> <td> Hot water supply</td> <td> Auto heating</td> <td> Auto cooling</td> </tr> <tr> <td> Heat pump operating</td> <td></td> <td></td> <td></td> </tr> </table> | Heating | Cooling | Auto | Hot water supply | Auto heating | Auto cooling | Heat pump operating | | | |
| Heating | Cooling | | | | | | | | | | |
| Auto | Hot water supply | Auto heating | Auto cooling | | | | | | | | |
| Heat pump operating | | | | | | | | | | | |
| 4: Temp setting | Set room temp Compensation curve Set direct water temp Set pool temp | | | | | | | | | | |
| 5: Display Heat temp | Displays current heating temperature (it is set temperature when enclosed by line) | | | | | | | | | | |
| 6: Outdoor temp | Displays outdoor temperature | | | | | | | | | | |
| 7: Display tank temp | Displays current tank temperature (it is set temperature when enclosed by line) | | | | | | | | | | |
| 8: Electrical anodes | Normal Abnormal (Flashing) Not used (Hidden) | | | | | | | | | | |

First time of power ON (Start of installation)



When the power is ON, firstly the initialization screen appears (approx. 10 sec)

↓ Approx, 10 sec later.

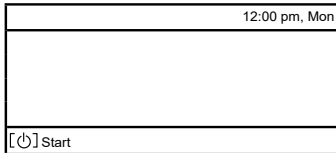

When the initialization screen ends, it turns to normal screen.

↓ Press any key

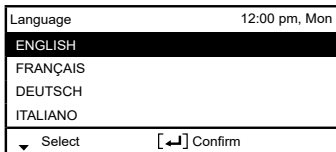

When any button is pressed, language setting screen appears.

Note: If initial setting is not performed, it does not go into menu.

When there are two remote controllers installed from the beginning, the first remote controller used to set and confirm language will be recognised as the main remote controller.

↓ Set language and press confirm

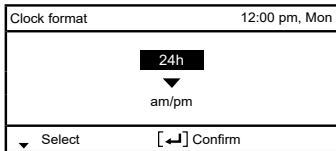

When language is set, setting screen of time display appears (24h/am/pm)

↓ Set time display and press confirm

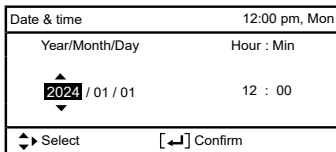

YYYY/MM/DD/Time setup screen appears

↓ Set YY/MM/DD/Time & confirm

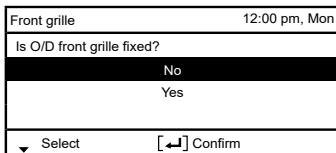

Select 'No' to confirm, before continuing with the operation, a caution message confirming the installation of the outdoor front grille will be displayed.

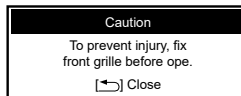

↓ Set Yes & confirm if outdoor front grille has been installed

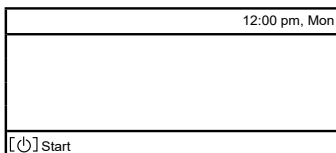

Back to initial screen

↓ Press Menu and select Installer setup

| | |
|------------------------|---------------|
| Main menu | 12:00 pm, Mon |
| System check | |
| Personal setup | |
| Service contact | |
| Installer setup | |
| ▲ Select | [↵] Confirm |

↓ Confirm to go into Installer setup

3-2. Installer Setup

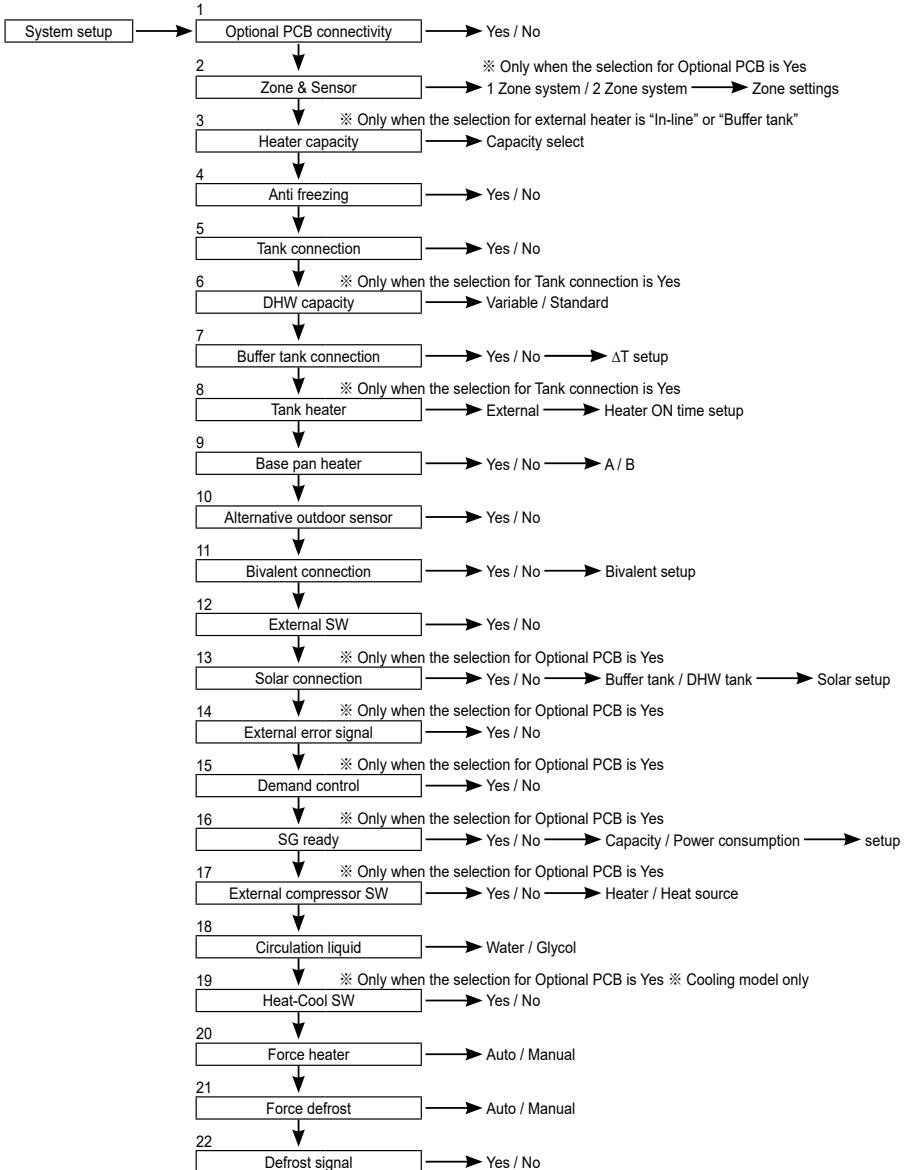

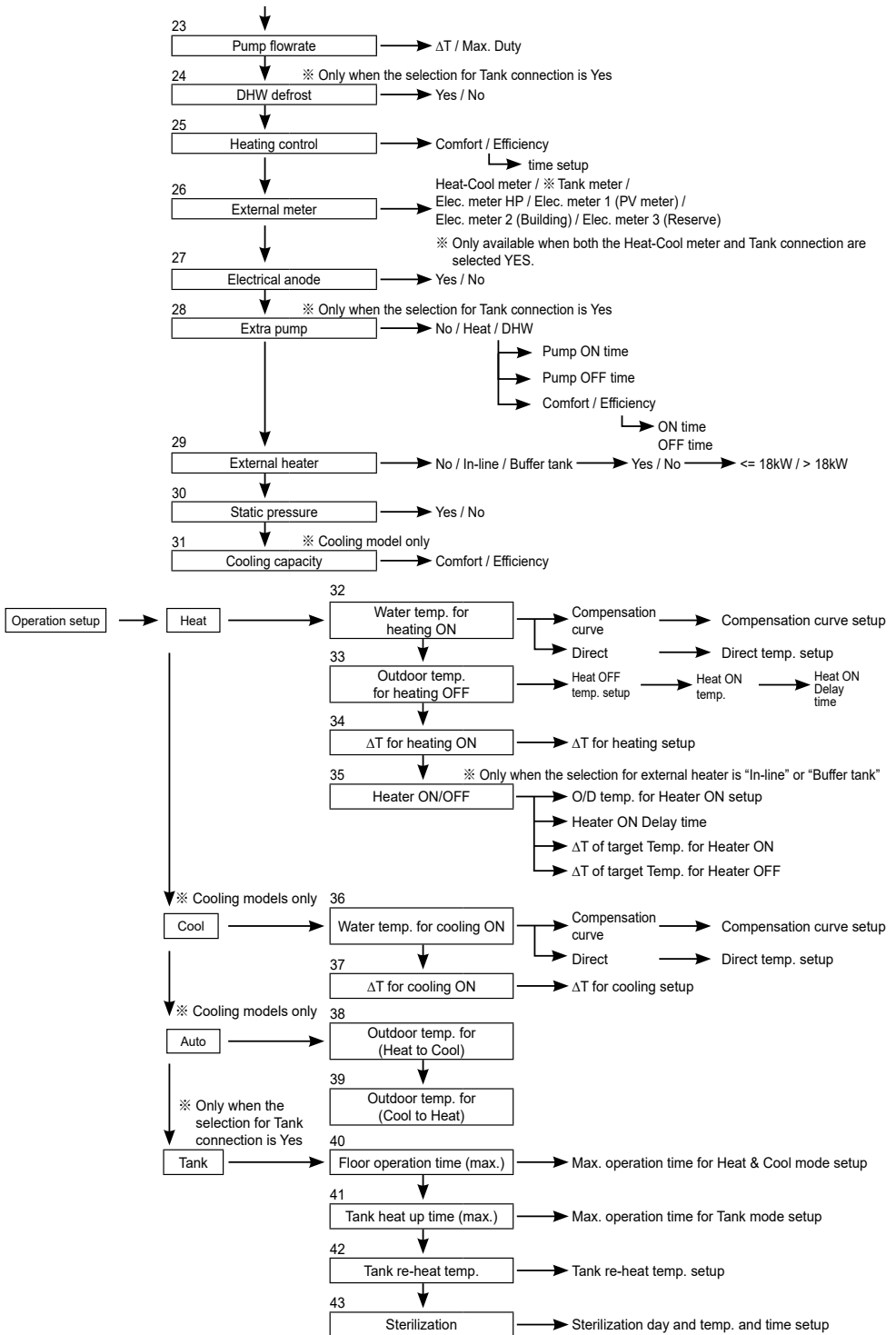

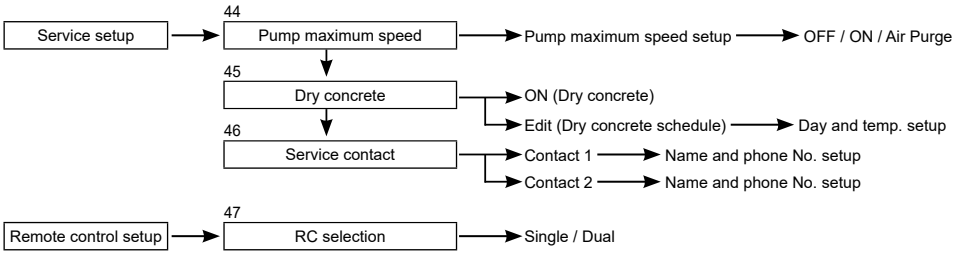

3-3. System setup

| | | | | | | | | | | | | | | |
|--|--|--|--------------|---------------|---------------------------|--|---------------|--|-----------------|--|---------------|--|----------|-------------|
| <div style="border: 1px solid black; display: inline-block; padding: 2px 5px;">1. Optional PCB connectivity</div> | <div style="border: 1px solid black; display: inline-block; padding: 2px 5px;">Initial setting: No</div> | <table border="1" style="width: 100%; border-collapse: collapse;"> <tr> <td style="text-align: right;">System setup</td> <td style="text-align: right;">12:00 pm, Mon</td> </tr> <tr> <td colspan="2" style="background-color: #f0f0f0;">Optional PCB connectivity</td> </tr> <tr> <td colspan="2">Zone & Sensor</td> </tr> <tr> <td colspan="2">Heater capacity</td> </tr> <tr> <td colspan="2">Anti freezing</td> </tr> <tr> <td style="text-align: right;">▼ Select</td> <td style="text-align: right;">[↵] Confirm</td> </tr> </table> | System setup | 12:00 pm, Mon | Optional PCB connectivity | | Zone & Sensor | | Heater capacity | | Anti freezing | | ▼ Select | [↵] Confirm |
| System setup | 12:00 pm, Mon | | | | | | | | | | | | | |
| Optional PCB connectivity | | | | | | | | | | | | | | |
| Zone & Sensor | | | | | | | | | | | | | | |
| Heater capacity | | | | | | | | | | | | | | |
| Anti freezing | | | | | | | | | | | | | | |
| ▼ Select | [↵] Confirm | | | | | | | | | | | | | |

If any functions below is necessary, purchase and install (CZ-NS7P).
Select Yes after installing it.

- 2-zone control
- Pool
- Solar
- External error signal output
- Demand control
- SG ready
- Stop heat source unit by external SW
- Heat-Cool SW

| | | | | | | | | | | | | | | |
|--|--|---|--------------|---------------|---------------------------|--|---------------|--|-----------------|--|---------------|--|----------|-------------|
| <div style="border: 1px solid black; display: inline-block; padding: 2px 5px;">2. Zone & Sensor</div> | <div style="border: 1px solid black; display: inline-block; padding: 2px 5px;">Initial setting: Room and Water temp.</div> | <table border="1" style="width: 100%; border-collapse: collapse;"> <tr> <td style="text-align: right;">System setup</td> <td style="text-align: right;">12:00 pm, Mon</td> </tr> <tr> <td colspan="2" style="background-color: #f0f0f0;">Optional PCB connectivity</td> </tr> <tr> <td colspan="2" style="background-color: #f0f0f0;">Zone & Sensor</td> </tr> <tr> <td colspan="2">Heater capacity</td> </tr> <tr> <td colspan="2">Anti freezing</td> </tr> <tr> <td style="text-align: right;">▲ Select</td> <td style="text-align: right;">[↵] Confirm</td> </tr> </table> | System setup | 12:00 pm, Mon | Optional PCB connectivity | | Zone & Sensor | | Heater capacity | | Anti freezing | | ▲ Select | [↵] Confirm |
| System setup | 12:00 pm, Mon | | | | | | | | | | | | | |
| Optional PCB connectivity | | | | | | | | | | | | | | |
| Zone & Sensor | | | | | | | | | | | | | | |
| Heater capacity | | | | | | | | | | | | | | |
| Anti freezing | | | | | | | | | | | | | | |
| ▲ Select | [↵] Confirm | | | | | | | | | | | | | |

If there is no Optional PCB
Select sensor of room temperature control from the following 3 items

- ① Water temperature (circulation water temperature)
- ② Room thermostat (Internal or External)
- ③ Room thermistor

If there is Optional PCB

- ① Select either 1-zone control or 2 zone control.
For 1-zone, select either room or pool, select sensor
For 2-zone, select the sensor in zone 1, then the either room or pool for zone 2 and select the sensor

Note: In 2-zone system, pool function can be set to zone 2 only.

| | | | | | | | | | | | | | | |
|--|---|--|--------------|---------------|---------------------------|--|---------------|--|-----------------|--|---------------|--|----------|-------------|
| <div style="border: 1px solid black; display: inline-block; padding: 2px 5px;">3. Heater capacity</div> | <div style="border: 1px solid black; display: inline-block; padding: 2px 5px;">Initial setting: Depend on model</div> | <table border="1" style="width: 100%; border-collapse: collapse;"> <tr> <td style="text-align: right;">System setup</td> <td style="text-align: right;">12:00 pm, Mon</td> </tr> <tr> <td colspan="2" style="background-color: #f0f0f0;">Optional PCB connectivity</td> </tr> <tr> <td colspan="2" style="background-color: #f0f0f0;">Zone & Sensor</td> </tr> <tr> <td colspan="2" style="background-color: #f0f0f0;">Heater capacity</td> </tr> <tr> <td colspan="2">Anti freezing</td> </tr> <tr> <td style="text-align: right;">▲ Select</td> <td style="text-align: right;">[↵] Confirm</td> </tr> </table> | System setup | 12:00 pm, Mon | Optional PCB connectivity | | Zone & Sensor | | Heater capacity | | Anti freezing | | ▲ Select | [↵] Confirm |
| System setup | 12:00 pm, Mon | | | | | | | | | | | | | |
| Optional PCB connectivity | | | | | | | | | | | | | | |
| Zone & Sensor | | | | | | | | | | | | | | |
| Heater capacity | | | | | | | | | | | | | | |
| Anti freezing | | | | | | | | | | | | | | |
| ▲ Select | [↵] Confirm | | | | | | | | | | | | | |

If there is external heater, set the heater capacity.

Note: Some heaters cannot select the capacity.

Note: When using the SG-ready function, use a heater with a capacity less than the required value.

| | | | | | | | | | | | | | | |
|--|---|---|--------------|---------------|---------------------------|--|---------------|--|-----------------|--|---------------|--|----------|-------------|
| <div style="border: 1px solid black; display: inline-block; padding: 2px 5px;">4. Anti freezing</div> | <div style="border: 1px solid black; display: inline-block; padding: 2px 5px;">Initial setting: Yes</div> | <table border="1" style="width: 100%; border-collapse: collapse;"> <tr> <td style="text-align: right;">System setup</td> <td style="text-align: right;">12:00 pm, Mon</td> </tr> <tr> <td colspan="2" style="background-color: #f0f0f0;">Optional PCB connectivity</td> </tr> <tr> <td colspan="2" style="background-color: #f0f0f0;">Zone & Sensor</td> </tr> <tr> <td colspan="2" style="background-color: #f0f0f0;">Heater capacity</td> </tr> <tr> <td colspan="2" style="background-color: #f0f0f0;">Anti freezing</td> </tr> <tr> <td style="text-align: right;">▲ Select</td> <td style="text-align: right;">[↵] Confirm</td> </tr> </table> | System setup | 12:00 pm, Mon | Optional PCB connectivity | | Zone & Sensor | | Heater capacity | | Anti freezing | | ▲ Select | [↵] Confirm |
| System setup | 12:00 pm, Mon | | | | | | | | | | | | | |
| Optional PCB connectivity | | | | | | | | | | | | | | |
| Zone & Sensor | | | | | | | | | | | | | | |
| Heater capacity | | | | | | | | | | | | | | |
| Anti freezing | | | | | | | | | | | | | | |
| ▲ Select | [↵] Confirm | | | | | | | | | | | | | |

Operate anti-freezing of water circulation circuit.
If set to yes, the pump will start when the water temperature reaches its freezing temperature.
If the temperature does not reach the pump stop temperature, heat pump will be activated.

Note: If set to No, when the water temperature reaches its freezing temperature or below, the water circulation circuit may freeze and cause malfunction.

| | | | | | | | | | | | | | | |
|--|--|---|--------------|---------------|---------------|--|-----------------|--|---------------|--|-----------------|--|----------|-------------|
| <div style="border: 1px solid black; display: inline-block; padding: 2px 5px;">5. Tank connection</div> | <div style="border: 1px solid black; display: inline-block; padding: 2px 5px;">Initial setting: No</div> | <table border="1" style="width: 100%; border-collapse: collapse;"> <tr> <td style="text-align: right;">System setup</td> <td style="text-align: right;">12:00 pm, Mon</td> </tr> <tr> <td colspan="2" style="background-color: #f0f0f0;">Zone & Sensor</td> </tr> <tr> <td colspan="2" style="background-color: #f0f0f0;">Heater capacity</td> </tr> <tr> <td colspan="2" style="background-color: #f0f0f0;">Anti freezing</td> </tr> <tr> <td colspan="2" style="background-color: #f0f0f0;">Tank connection</td> </tr> <tr> <td style="text-align: right;">▲ Select</td> <td style="text-align: right;">[↵] Confirm</td> </tr> </table> | System setup | 12:00 pm, Mon | Zone & Sensor | | Heater capacity | | Anti freezing | | Tank connection | | ▲ Select | [↵] Confirm |
| System setup | 12:00 pm, Mon | | | | | | | | | | | | | |
| Zone & Sensor | | | | | | | | | | | | | | |
| Heater capacity | | | | | | | | | | | | | | |
| Anti freezing | | | | | | | | | | | | | | |
| Tank connection | | | | | | | | | | | | | | |
| ▲ Select | [↵] Confirm | | | | | | | | | | | | | |

Select whether it is connected to hot water tank or not.
If set to Yes, it enables the hot water function settings.
Hot water temperature of the tank can be set from main screen.

6. DHW capacity

Initial setting: Variable

Variable DHW capacity setting normally run with efficient boiling which is energy saving heating. However while hot water usage high and tank water temperature low, variable DHW mode run with fast heat up which heat up the tank with high heating capacity.

If standard DHW capacity setting is selected, heat pump run with heating rated capacity at tank heat up operation.

| | |
|---------------------|---------------|
| System setup | 12:00 pm, Mon |
| Heater capacity | |
| Anti freezing | |
| Tank connection | |
| DHW capacity | |
| ⬇ Select | [↵] Confirm |

7. Buffer Tank connection

Initial setting: No

Select whether it is connected to buffer tank for heating or not.

If buffer tank is used, set to Yes.

Connect buffer tank thermistor and set ΔT (ΔT use to increase primary side temperature against secondary side target temperature).

If the buffer tank capacity is not so large, set larger value for ΔT .

| | |
|-------------------------------|---------------|
| System setup | 12:00 pm, Mon |
| Anti freezing | |
| Tank connection | |
| DHW capacity | |
| Buffer tank connection | |
| ⬇ Select | [↵] Confirm |

8. Tank heater

Initial setting: External

Note: Does not display if there is no tank for hot water supply.

Set "Tank heater" to "ON" in the "Function setup" from remote controller when using heater to boil the tank.

External A setting which is using booster heater installed on DHW tank to boil the tank.
The permissible heater capacity is 3kW and below.
The operation to boil the tank with heater is as below.
In addition, set the "Tank heater: ON time" appropriately.

| | |
|------------------------|---------------|
| System setup | 12:00 pm, Mon |
| Tank connection | |
| DHW capacity | |
| Buffer tank connection | |
| Tank heater | |
| ⬇ Select | [↵] Confirm |

For 65°C setting

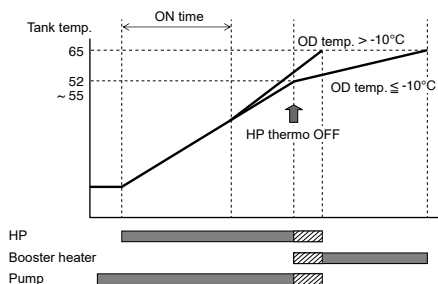

9. Base pan heater

Initial setting: No

Select whether Base pan heater is installed or not.

If set to Yes, select to use either heater A or B.

A: Turn ON Heater when heating with defrost operation only

B: Turn ON Heater at heating

| | |
|------------------------|---------------|
| System setup | 12:00 pm, Mon |
| DHW capacity | |
| Buffer tank connection | |
| Tank heater | |
| Base pan heater | |
| ⬇ Select | [↵] Confirm |

10. Alternative outdoor sensor

Initial setting: No

Set to Yes if outdoor sensor is installed.
Controlled by optional outdoor sensor without reading the outdoor sensor of heat pump unit.

| | |
|-----------------------------------|---------------|
| System setup | 12:00 pm, Mon |
| Buffer tank connection | |
| Tank heater | |
| Base pan heater | |
| Alternative outdoor sensor | |
| ⬆ Select | [↵] Confirm |

11. Bivalent connection

Initial setting: No

Set if heat pump linked with boiler operation.
Connect the start signal of the boiler in boiler contact terminal (PCB).
Set Bivalent connection to YES.
After that, begin setting according to remote controller instruction.
Boiler icon will be displayed on remote controller top screen.

| | |
|----------------------------|---------------|
| System setup | 12:00 pm, Mon |
| Tank heater | |
| Base pan heater | |
| Alternative outdoor sensor | |
| Bivalent connection | |
| ⬆ Select | [↵] Confirm |

After Bivalent connection set YES, there are three options of control pattern (Auto / SG Ready / Smart).

1) Auto

There are 3 different modes in the boiler auto pattern operation. Movement of each modes are shown below.

- ② Alternative (switch to boiler operation when drops below setting temperature)
- ③ Parallel (allow boiler operation when drops below setting temperature)
- ④ Advanced Parallel (able to slightly delay boiler operation time of parallel operation)

When the boiler operation is "ON", "boiler contact" is "ON", " _ "(underscore) will be displayed below the boiler icon.

Set target temperature of boiler to be the same as heat pump temperature.

When boiler temperature is higher than heat pump temperature, zone temperature cannot be achieved if mixing valve is not installed.

This product only allows one signal to control the boiler operation. Operation setting of boiler shall be responsible by installer.

Alternative mode

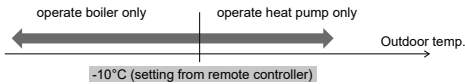

Parallel mode

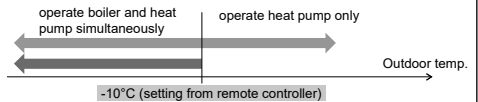

Advanced Parallel mode

For heating

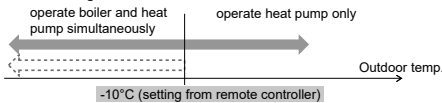

For DHW tank

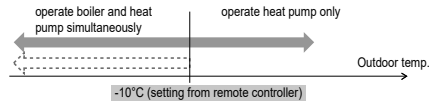

Although heat pump operates but water temperature does not reach this temperature for more than 30 mins (setting from remote controller)

AND

If actual tank temp. does not achieve the setting temp. within 30min (setting from remote controller), the boiler turn ON

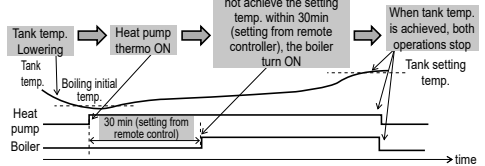
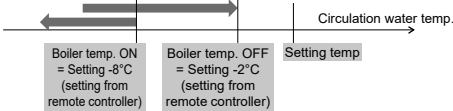

In Advanced Parallel mode, setting for both heating and tank can be made simultaneously. During operation of "Heating/Tank" mode, when each time the mode is switched, the boiler output will be reset to OFF. Please have a good understanding on the boiler control characteristic in order to select the optimal setting for the system.

- 2) SG ready (Only available to set when optional PCB set to YES)
 - SG Ready input from optional PCB terminal control ON/OFF of boiler and heat pump as below condition

| SG signal | | Operation pattern |
|-----------|----------|---------------------------|
| Vcc-bit1 | Vcc-bit2 | |
| Open | Open | Heat pump OFF, Boiler OFF |
| Short | Open | Heat pump ON, Boiler OFF |
| Open | Short | Heat pump OFF, Boiler ON |
| Short | Short | Heat pump ON, Boiler ON |

* This bivalent SG ready input is sharing same terminal as [16. SG ready] connection. Only one of these two setting can be set at the same time. When one is set, another setting will reset to not set.

- 3) Smart
 There are Energy price (both electricity and boiler) and Schedule to be set on remote controller.
 Operation setting of Energy price and Schedule shall be responsible by installer.
 Based on these settings, system will calculate the final price for both electricity and boiler.
 When final price of Electricity is lower than Boiler's, heat pump will operate.
 When final price of Electricity is higher than Boiler's, boiler will operate.

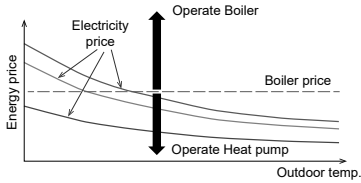

12. External SW

Initial setting: No

Able to turn ON/OFF the operation by external switch.

| | |
|----------------------------|---------------|
| System setup | 12:00 pm, Mon |
| Base pan heater | |
| Alternative outdoor sensor | |
| Bivalent connection | |
| External SW | |
| ◀ Select | [↵] Confirm |

13. Solar connection

Initial setting: No

Set when solar water heater is installed.

Setting include items below.

- ① Set either buffer tank or DHW tank for connection with solar water heater.
- ② Set temperature difference between solar panel thermistor and buffer tank or DHW tank thermistor to operate the solar pump.
- ③ Set temperature difference between solar panel thermistor and buffer tank or DHW tank thermistor to stop the solar pump.
- ④ Anti-freezing operation start temperature (change setting based on usage of glycol.)
- ⑤ Solar pump stop operation when it exceeds high limit temperature (when tank temperature exceed designated temperature (70~90°C))

Note: Does not display if there is no Optional PCB.

| | |
|----------------------------|---------------|
| System setup | 12:00 pm, Mon |
| Alternative outdoor sensor | |
| Bivalent connection | |
| External SW | |
| Solar connection | |
| ◀ Select | [↵] Confirm |

14. External Error Signal

Initial setting: No

Set when external error display unit is installed.
 Turn ON Dry Contact SW when error happened.

Note: Does not display if there is no Optional PCB.
 When error occurs, error signal will be ON.
 After turn OFF "close" from the display, error signal will still remain ON.

| | |
|------------------------------|---------------|
| System setup | 12:00 pm, Mon |
| Bivalent connection | |
| External SW | |
| Solar connection | |
| External error signal | |
| ◀ Select | [↵] Confirm |

15. Demand control

Initial setting: No

System setup 12:00 pm, Mon

- External SW
- Solar connection
- External error signal

Demand control

⬆ Select [↵] Confirm

Set when there is demand control.
Adjust terminal voltage within 1 ~ 10 V to change the operating current limit.

Note: Does not display if there is no Optional PCB.

| Analog input [V] | Rate [%] |
|------------------|--------------|
| 0.0 | not activate |
| 0.1 ~ 0.6 | not activate |
| 0.7 | 10 |
| 0.8 | 10 |
| 0.9 ~ 1.1 | 15 |
| 1.2 | 15 |
| 1.3 | 15 |
| 1.4 ~ 1.6 | 20 |
| 1.7 | 20 |
| 1.8 | 20 |
| 1.9 ~ 2.1 | 25 |
| 2.2 | 25 |
| 2.3 | 25 |
| 2.4 ~ 2.6 | 30 |
| 2.7 | 30 |
| 2.8 | 30 |
| 2.9 ~ 3.1 | 35 |
| 3.2 | 35 |
| 3.3 | 35 |
| 3.4 ~ 3.6 | 40 |
| 3.7 | 40 |
| 3.8 | 40 |

| Analog input [V] | Rate [%] |
|------------------|----------|
| 3.9 ~ 4.1 | 45 |
| 4.2 | 45 |
| 4.3 | 45 |
| 4.4 ~ 4.6 | 50 |
| 4.7 | 50 |
| 4.8 | 50 |
| 4.9 ~ 5.1 | 55 |
| 5.2 | 55 |
| 5.3 | 55 |
| 5.4 ~ 5.6 | 60 |
| 5.7 | 60 |
| 5.8 | 60 |
| 5.9 ~ 6.1 | 65 |
| 6.2 | 65 |
| 6.3 | 65 |
| 6.4 ~ 6.6 | 70 |
| 6.7 | 70 |
| 6.8 | 70 |
| 6.9 ~ 7.1 | 75 |
| 7.2 | 75 |
| 7.3 | 75 |

| Analog input [V] | Rate [%] |
|------------------|----------|
| 7.4 ~ 7.6 | 80 |
| 7.7 | 80 |
| 7.8 | 80 |
| 7.9 ~ 8.1 | 85 |
| 8.2 | 85 |
| 8.3 | 85 |
| 8.4 ~ 8.6 | 90 |
| 8.7 | 90 |
| 8.8 | 90 |
| 8.9 ~ 9.1 | 95 |
| 9.2 | 95 |
| 9.3 | 95 |
| 9.4 ~ 9.6 | 100 |
| 9.7 | 100 |
| 9.8 | 100 |
| 9.9 ~ | 100 |

*A minimum operating current is applied on each model for protection purpose.

*0.2 voltage hysteresis is provided.

*The value of voltage after 2nd decimal point are cut off.

16. SG Ready

Initial setting: No

Switch operation of heat pump by open-short of 2 terminals.
The following settings are possible.
Capacity: limit by capacity.
Power consumption: limit by power consumption.

| SG signal | | Operation pattern |
|-----------|----------|----------------------|
| Vcc-bit1 | Vcc-bit2 | |
| Open | Open | Normal |
| Short | Open | Heat pump/heater OFF |
| Open | Short | Capacity 1 |
| Short | Short | Capacity 2 |

Select Capacity

Capacity setting 1

- DHW capacity ___%.
- Heating capacity ___%.
- Cooling capacity ___°C

Capacity setting 2

- DHW capacity ___%.
- Heating capacity ___%.
- Cooling capacity ___°C

} SG ready - Yes - Capacity setting

Select Power consumption

HPU stop consumption ___kW
HPU stop consumption value never exceeded
If the value is exceeded, heating is provided by the heater only.

Power consumption setting 1

- Power consumption of DHW ___kW
- Heating power consumption ___kW
- Cooling power consumption ___kW

Power consumption setting 2

- Power consumption of DHW ___kW
- Heating power consumption ___kW
- Cooling power consumption ___kW

} SG ready - Yes - Power consumption setting

(If SG ready is set to 'Yes', Bivalent control pattern is set to 'Auto').
Note: Does not display if there is no Optional PCB.
Note: Be sure to use a heater with a capacity below the value set by "HP stop consumption"

System setup 12:00 pm, Mon

Solar connection

External error signal

Demand control

SG Ready

⬇ Select [↵] Confirm

17. External compressor SW

Initial setting: No

Set when external compressor SW is connected.
SW is connected to external devices to control power consumption, Open Signal will stop compressor's operation. (Heating operation etc. are not cancelled).

Note: Does not display if there is no Optional PCB.

System setup 12:00 pm, Mon

External error signal

Demand control

SG Ready

External compressor SW

⬇ Select [↵] Confirm

18. Circulation Liquid

Initial setting: Water

Set circulation of heating water.

There are 2 types of settings, water and glycol.

Note: Set glycol when using anti-freeze liquid.
It may cause error if setting is wrong.

System setup 12:00 pm, Mon

Demand control

SG Ready

External compressor SW

Circulation liquid

⬇ Select [↵] Confirm

| | | | | | | | | | | | | | | |
|--|--------------------------|---|--------------|---------------|----------|--|------------------------|--|--------------------|--|--------------|--|----------|-------------|
| 19. Heat-Cool SW | Initial setting: Disable | <table border="1" style="width: 100%; border-collapse: collapse;"> <tr> <td style="text-align: right;">System setup</td> <td style="text-align: right;">12:00 pm, Mon</td> </tr> <tr> <td colspan="2">SG Ready</td> </tr> <tr> <td colspan="2">External compressor SW</td> </tr> <tr> <td colspan="2">Circulation liquid</td> </tr> <tr> <td colspan="2" style="background-color: #333; color: white;">Heat-Cool SW</td> </tr> <tr> <td style="text-align: right;">⬇ Select</td> <td style="text-align: right;">[↵] Confirm</td> </tr> </table> | System setup | 12:00 pm, Mon | SG Ready | | External compressor SW | | Circulation liquid | | Heat-Cool SW | | ⬇ Select | [↵] Confirm |
| System setup | 12:00 pm, Mon | | | | | | | | | | | | | |
| SG Ready | | | | | | | | | | | | | | |
| External compressor SW | | | | | | | | | | | | | | |
| Circulation liquid | | | | | | | | | | | | | | |
| Heat-Cool SW | | | | | | | | | | | | | | |
| ⬇ Select | [↵] Confirm | | | | | | | | | | | | | |
| <p>Able to switch (fix) heating & cooling by external switch.</p> <p>(Open) : Fix at Heating (Heating +DHW) (Short) : Fix at Cooling (Cooling +DHW) Note: This setting is disabled for model without Cooling. Note: Does not display if there is no Optional PCB.</p> <p>Timer function cannot be used. Cannot use Auto mode.</p> | | | | | | | | | | | | | | |

| | | | | | | | | | | | | | | |
|--|-------------------------|---|--------------|---------------|------------------------|--|--------------------|--|--------------|--|--------------|--|----------|-------------|
| 20. Force Heater | Initial setting: Manual | <table border="1" style="width: 100%; border-collapse: collapse;"> <tr> <td style="text-align: right;">System setup</td> <td style="text-align: right;">12:00 pm, Mon</td> </tr> <tr> <td colspan="2">External compressor SW</td> </tr> <tr> <td colspan="2">Circulation liquid</td> </tr> <tr> <td colspan="2">Heat-Cool SW</td> </tr> <tr> <td colspan="2" style="background-color: #333; color: white;">Force heater</td> </tr> <tr> <td style="text-align: right;">⬇ Select</td> <td style="text-align: right;">[↵] Confirm</td> </tr> </table> | System setup | 12:00 pm, Mon | External compressor SW | | Circulation liquid | | Heat-Cool SW | | Force heater | | ⬇ Select | [↵] Confirm |
| System setup | 12:00 pm, Mon | | | | | | | | | | | | | |
| External compressor SW | | | | | | | | | | | | | | |
| Circulation liquid | | | | | | | | | | | | | | |
| Heat-Cool SW | | | | | | | | | | | | | | |
| Force heater | | | | | | | | | | | | | | |
| ⬇ Select | [↵] Confirm | | | | | | | | | | | | | |
| <p>Under manual mode, user can turn ON force heater through quick menu.</p> <p>If selection is 'auto', force heater mode will turn automatically if pop up error happen during operation. Note: When external heater is No and tank heater is OFF, force heater does not turn ON even if selection is 'auto'. Force heater operation follows the latest mode selection. Mode selection is disable under force heater operation.</p> <p>Heater source will ON during force heater mode.</p> | | | | | | | | | | | | | | |

| | | | | | | | | | | | | | | |
|--|-------------------------|--|--------------|---------------|--------------------|--|--------------|--|--------------|--|---------------|--|----------|-------------|
| 21. Force Defrost | Initial setting: Manual | <table border="1" style="width: 100%; border-collapse: collapse;"> <tr> <td style="text-align: right;">System setup</td> <td style="text-align: right;">12:00 pm, Mon</td> </tr> <tr> <td colspan="2">Circulation liquid</td> </tr> <tr> <td colspan="2">Heat-Cool SW</td> </tr> <tr> <td colspan="2">Force heater</td> </tr> <tr> <td colspan="2" style="background-color: #333; color: white;">Force defrost</td> </tr> <tr> <td style="text-align: right;">⬇ Select</td> <td style="text-align: right;">[↵] Confirm</td> </tr> </table> | System setup | 12:00 pm, Mon | Circulation liquid | | Heat-Cool SW | | Force heater | | Force defrost | | ⬇ Select | [↵] Confirm |
| System setup | 12:00 pm, Mon | | | | | | | | | | | | | |
| Circulation liquid | | | | | | | | | | | | | | |
| Heat-Cool SW | | | | | | | | | | | | | | |
| Force heater | | | | | | | | | | | | | | |
| Force defrost | | | | | | | | | | | | | | |
| ⬇ Select | [↵] Confirm | | | | | | | | | | | | | |
| <p>Under manual mode, user can turn ON force defrost through quick menu.</p> <p>If selection is 'auto', outdoor unit will run defrost operation once if heat pump have long hour of heating without any defrost operation before at low ambient condition. (Even if auto is selected, user still can turn ON force defrost through quick menu)</p> | | | | | | | | | | | | | | |

| | | | | | | | | | | | | | | |
|--|---------------------|--|--------------|---------------|--------------|--|--------------|--|---------------|--|----------------|--|----------|-------------|
| 22. Defrost signal | Initial setting: No | <table border="1" style="width: 100%; border-collapse: collapse;"> <tr> <td style="text-align: right;">System setup</td> <td style="text-align: right;">12:00 pm, Mon</td> </tr> <tr> <td colspan="2">Heat-Cool SW</td> </tr> <tr> <td colspan="2">Force heater</td> </tr> <tr> <td colspan="2">Force defrost</td> </tr> <tr> <td colspan="2" style="background-color: #333; color: white;">Defrost signal</td> </tr> <tr> <td style="text-align: right;">⬇ Select</td> <td style="text-align: right;">[↵] Confirm</td> </tr> </table> | System setup | 12:00 pm, Mon | Heat-Cool SW | | Force heater | | Force defrost | | Defrost signal | | ⬇ Select | [↵] Confirm |
| System setup | 12:00 pm, Mon | | | | | | | | | | | | | |
| Heat-Cool SW | | | | | | | | | | | | | | |
| Force heater | | | | | | | | | | | | | | |
| Force defrost | | | | | | | | | | | | | | |
| Defrost signal | | | | | | | | | | | | | | |
| ⬇ Select | [↵] Confirm | | | | | | | | | | | | | |
| <p>Defrost signal and bivalent connection have the same connection port in the main PCB. When defrost signal set to YES, bivalent connection reset to NO. Only one function can be set between defrost signal and bivalent.</p> <p>When defrost signal set to YES, during defrost operation is running at outdoor unit defrost signal contact turn ON. Defrost signal contact turn OFF after defrost operation end. (Purpose of this contact output is to stop indoor fan coil or water pump during defrost operation).</p> | | | | | | | | | | | | | | |

| | | | | | | | | | | | | | | |
|---|-----------------------------|---|--------------|---------------|--------------|--|---------------|--|----------------|--|---------------|--|----------|-------------|
| 23. Pump flowrate | Initial setting: ΔT | <table border="1" style="width: 100%; border-collapse: collapse;"> <tr> <td style="text-align: right;">System setup</td> <td style="text-align: right;">12:00 pm, Mon</td> </tr> <tr> <td colspan="2">Force heater</td> </tr> <tr> <td colspan="2">Force defrost</td> </tr> <tr> <td colspan="2">Defrost signal</td> </tr> <tr> <td colspan="2" style="background-color: #333; color: white;">Pump flowrate</td> </tr> <tr> <td style="text-align: right;">⬇ Select</td> <td style="text-align: right;">[↵] Confirm</td> </tr> </table> | System setup | 12:00 pm, Mon | Force heater | | Force defrost | | Defrost signal | | Pump flowrate | | ⬇ Select | [↵] Confirm |
| System setup | 12:00 pm, Mon | | | | | | | | | | | | | |
| Force heater | | | | | | | | | | | | | | |
| Force defrost | | | | | | | | | | | | | | |
| Defrost signal | | | | | | | | | | | | | | |
| Pump flowrate | | | | | | | | | | | | | | |
| ⬇ Select | [↵] Confirm | | | | | | | | | | | | | |
| <p>If pump flowrate setting is ΔT, unit adjust pump duty to get different of water inlet and outlet base on setting on * ΔT for heating ON and * ΔT for cooling ON in operation setup menu during room side operation.</p> <p>If pump flowrate setting is set to Max. duty, unit will set the pump duty to the set duty at *Pump maximum speed in service setup menu during room side operation.</p> | | | | | | | | | | | | | | |

| | | | | | | | |
|---|----------------------|--|---------------|----------------|---------------|-------------|--------------------|
| 24. DHW defrost | Initial setting: Yes | System setup 12:00 pm, Mon | | | | | |
| <p>When DHW defrost set to YES, hot water of domestic hot water tank will be used during defrost cycle. When DHW defrost set to NO, hot water of floor heating circuit will be used during defrost cycle.</p> | | <table border="1" style="width: 100%; border-collapse: collapse;"> <tr><td>Force defrost</td></tr> <tr><td>Defrost signal</td></tr> <tr><td>Pump flowrate</td></tr> <tr style="background-color: #333; color: white;"><td>DHW Defrost</td></tr> <tr><td style="text-align: right;">Select [↵] Confirm</td></tr> </table> | Force defrost | Defrost signal | Pump flowrate | DHW Defrost | Select [↵] Confirm |
| Force defrost | | | | | | | |
| Defrost signal | | | | | | | |
| Pump flowrate | | | | | | | |
| DHW Defrost | | | | | | | |
| Select [↵] Confirm | | | | | | | |

| | | | | | | | |
|---|--------------------------|--|----------------|---------------|-------------|-----------------|--------------------|
| 25. Heating control | Initial setting: Comfort | System setup 12:00 pm, Mon | | | | | |
| <p>Compressor frequency control can be selected from two modes: Comfort and Efficiency. Select "Comfort" - The compressor operates at the maximum frequency at the upper zone limit and reaches the set temperature faster. Select "Efficiency" - The compressor frequency is gradually increased to reduce power consumption. The system have 3 steps to achieve maximum compressor frequency. You can set period time of each stage on R/C. (compressor frequency for each stage) 1st stage: 50% of the maximum frequency 2nd stage: 66% of the maximum frequency 3rd stage: 83% of the maximum frequency</p> | | <table border="1" style="width: 100%; border-collapse: collapse;"> <tr><td>Defrost signal</td></tr> <tr><td>Pump flowrate</td></tr> <tr><td>DHW Defrost</td></tr> <tr style="background-color: #333; color: white;"><td>Heating control</td></tr> <tr><td style="text-align: right;">Select [↵] Confirm</td></tr> </table> | Defrost signal | Pump flowrate | DHW Defrost | Heating control | Select [↵] Confirm |
| Defrost signal | | | | | | | |
| Pump flowrate | | | | | | | |
| DHW Defrost | | | | | | | |
| Heating control | | | | | | | |
| Select [↵] Confirm | | | | | | | |
| | | <p>Select Efficiency. Capacity</p> | | | | | |

| | | | | | | | |
|---|---|--|---------------|-------------|-----------------|----------------|--------------------|
| 26. External meter | Initial setting: [Heat-cool meter : No] [Tank meter : No] *only available when Heat-cool meter select Yes [Elec. meter HP : No] [Elec. meter 1 (PV meter) : No] [Elec. meter 2 (Building) : No] [Elec. meter 3 (Reserve) : No] | System setup 12:00 pm, Mon | | | | | |
| <p>There are two systems for generation meter connection : one generation meter system (Heat-cool meter) or two generation meter system (Heat-cool meter and Tank meter) Both systems can provide all generation data of heating, cooling and DHW directly from external meter. If Heat-cool meter is set to Yes, it will read from external meter for heat pump's energy generation data during heating, cooling and DHW operation ¹. If Heat-cool meter is set to No, it will base on unit's calculation for heat pump's energy generation data during heating, cooling and DHW operation. If Tank meter is set to Yes, it will read from external meter for heat pump's energy generation data during DHW operation ¹. If Elec. meter HP is set to Yes, it will read from external meter for heat pump's energy consumption data. If Elec. meter HP is set to No, it will base on unit's calculation for heat pump's energy consumption data. If Elec. meter 1 (PV meter) is set to Yes, it will read from external meter for energy generation data of solar system and display it on Cloud system. If Elec. meter 2 (Building) is set to Yes, it will read from external meter for energy consumption data of the building and display it on Cloud system. If Elec. meter 3 (Reserve) is set to Yes, it will read from external meter for energy consumption data obtained from reserved electricity meter and display it on Cloud system. ¹ Set Heat-cool meter to Yes and set Tank meter to No when 1 generation meter system is installed. Set Heat-cool meter to Yes and set Tank meter to Yes when 2 generation meter system is installed. Remark : Elec. meter HP refers to Electricity meter that measures Heat Pump unit's consumption. Elec. meter 1 / 2 / 3 refers to Electricity meter no. 1 / no. 2 / no. 3</p> | | <table border="1" style="width: 100%; border-collapse: collapse;"> <tr><td>Pump flowrate</td></tr> <tr><td>DHW Defrost</td></tr> <tr><td>Heating control</td></tr> <tr style="background-color: #333; color: white;"><td>External meter</td></tr> <tr><td style="text-align: right;">Select [↵] Confirm</td></tr> </table> | Pump flowrate | DHW Defrost | Heating control | External meter | Select [↵] Confirm |
| Pump flowrate | | | | | | | |
| DHW Defrost | | | | | | | |
| Heating control | | | | | | | |
| External meter | | | | | | | |
| Select [↵] Confirm | | | | | | | |

| | | | | | | | |
|---|---------------------|---|-------------|-----------------|----------------|------------------|--------------------|
| 27. Electrical anode | Initial setting: No | System setup 12:00 pm, Mon | | | | | |
| <p>Power can be supplied from the indoor unit when an electric anode is attached to an external tank.</p> | | <table border="1" style="width: 100%; border-collapse: collapse;"> <tr><td>DHW Defrost</td></tr> <tr><td>Heating control</td></tr> <tr><td>External meter</td></tr> <tr style="background-color: #333; color: white;"><td>Electrical anode</td></tr> <tr><td style="text-align: right;">Select [↵] Confirm</td></tr> </table> | DHW Defrost | Heating control | External meter | Electrical anode | Select [↵] Confirm |
| DHW Defrost | | | | | | | |
| Heating control | | | | | | | |
| External meter | | | | | | | |
| Electrical anode | | | | | | | |
| Select [↵] Confirm | | | | | | | |

28. Extra pump

Initial setting: Heat

Selects whether the extra pump is used in the circulation circuit for heating or in the circulation circuit for DHW, or it is not used.
If select for DHW, make choices such as the pump ON/OFF time and whether Comfort or Efficiency is a priority.

Select DHW

- Pump ON time 8:00
- Pump OFF time 20:00

Select Comfort (Exit extra pump settings)

Select Efficiency

- ON time 0:15 (0:05 ~ 1:00)
- OFF time 0:15 (0:05 ~ 1:00)

| | |
|-------------------|---------------|
| System setup | 12:00 pm, Mon |
| Heating control | |
| External meter | |
| Electrical anode | |
| Extra pump | |
| ◀ Select | [↵] Confirm |

Select DHW

Select Comfort

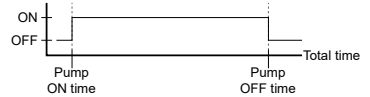

Select DHW

Select Efficiency

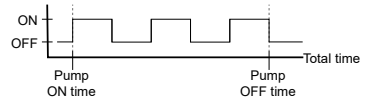
**29. External heater**

Initial setting: No

Select the type of external heater.

"In-line": Select this if you're using the external heater as an In-line heater.

"Buffer tank": Select this if you're using the external heater as a buffer tank heater.

Please refer to **3 CONNECT THE CABLE TO THE INDOOR UNIT** "how to install external heater" for details.

| | |
|------------------------|---------------|
| System setup | 12:00 pm, Mon |
| External meter | |
| Electrical anode | |
| Extra pump | |
| External heater | |
| ◀ Select | [↵] Confirm |

30. Static pressure

Initial setting: No

If set to No, the outdoor fan motor operates at a normal speed.

If set to YES, the outdoor fan motor operates at a higher speed than normal in response to high static pressure.

| | |
|------------------------|---------------|
| System setup | 12:00 pm, Mon |
| Electrical anode | |
| Extra pump | |
| External heater | |
| Static pressure | |
| ◀ Select | [↵] Confirm |

31. Cooling capacity

Initial setting: Efficiency

Select the cooling capacity.

If set to "Efficiency", the unit performs cooling operation efficiently at rated capacity.

If set to "Comfort", the cooling operation is performed at maximum capacity.

| | |
|-------------------------|---------------|
| System setup | 12:00 pm, Mon |
| Extra pump | |
| External heater | |
| Static pressure | |
| Cooling capacity | |
| ▲ Select | [↵] Confirm |

3-4. Operation setup

Heat

32. Water temp. for heating ON Initial setting: compensation curve

Set target water temperature to operate heating operation.
 Compensation curve: Target water temperature change in conjunction with outdoor ambient temperature change.
 Direct: Set direct circulation water temperature.

In 2 zone system, zone 1 and zone 2 water temperature can be set separately.

33. Outdoor temp. for heating OFF

If the operation of the outdoor unit is frequently switched on and off depending on the outdoor air temperature, the following settings can be used to reduce the frequency.

a. Outdoor temp. for heating OFF Initial setting: 24°C
 Set outdoor temp. to stop heating
 Setting range is 6°C~35°C

b. Outdoor temp. for heating ON Initial setting: 23°C
 Set outdoor temp. to start heating.
 Setting range is 5°C~X°C (X is heating OFF temp. -1)

c. Heating ON delay time Initial setting: 0:30min
 Set delay time from heating OFF to heating ON.

34. ΔT for heating ON Initial setting: 5°C

Set temp difference between out temp & return temp of circulating water of Heating operation.
 When temp gap is enlarged, it is energy saving but less comfort. When the gap gets smaller, energy saving effect gets worse but it is more comfortable.
 Setting range is 1°C ~ 15°C

35. Heater ON/OFF

a. Outdoor temp. for heater ON Initial setting: 0°C
 Set outdoor temp when back-up heater starts to operate.
 Setting range is -20°C ~ 15°C
 User shall set whether to use or not to use heater.

b. Heater ON delay time Initial setting: 30 minutes
 Set delay time from compressor ON for heater to turn ON if not achieve water set temperature.
 Setting range is 10 minutes ~ 60 minutes

c. Heater ON: ΔT of target Temp Initial setting: -4°C
 Set water temperature for heater to turn ON at heat mode.
 Setting range is -10°C ~ -2°C

d. Heater OFF: ΔT of target Temp Initial setting: -2°C
 Set water temperature for heater to turn OFF at heat mode.
 Setting range is -3°C ~ 0°C

Cool

36. Water temp. for cooling ON

Initial setting: compensation curve

Set target water temperature to operate cooling operation.
 Compensation curve: Target water temperature change in conjunction with outdoor ambient temperature change.
 Direct: Set direct circulation water temperature.

In 2 zone system, zone 1 and zone 2 water temperature can be set separately.

37. ΔT for cooling ON

Initial setting: 5°C

Set temp difference between out temp & return temp of circulating water of Cooling operation.
 When temp gap is enlarged, it is energy saving but less comfort. When the gap gets smaller, energy saving effect gets worse but it is more comfortable.
 Setting range is 1°C ~ 15°C

38. Outdoor temp. for (Heat to Cool)

Initial setting: 15°C

Set outdoor temp that switches from heating to cooling by Auto setting.
 Setting range is 11°C ~ 25°C
 Timing of judgement is every 1 hour

39. Outdoor temp. for (Cool to Heat)

Initial setting: 10°C

Set outdoor temp that switches from Cooling to Heating by Auto setting.
 Setting range is 5°C ~ 14°C
 Timing of judgement is every 1 hour

40. Floor operation time (max)

Initial setting: 8h

Set max operating hours of heating.
 When max operation time is shortened, it can boil the tank more frequently.
 It is a function for Heating + Tank operation.

41. Tank heat up time (max)

Initial setting: 60min

Set max boiling hours of tank.
 When max boiling hours are shortened, it immediately returns to Heating operation, but it may not fully boil the tank.

42. Tank re-heat temp.

Initial setting: -8°C

Set the temperature to re-boil the tank water.

Setting range is -12°C ~ -2°C

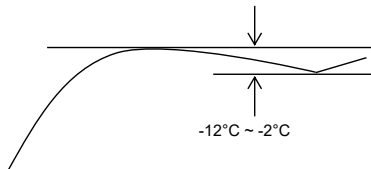

43. Sterilisation

Initial setting: 65°C 10 mins.

Set timer to perform sterilization.

- ① Set operating day & time. (Weekly timer format)
- ② Sterilization temperature (55~75°C)
- ③ Operation time (Time to run sterilization when it reached setting temperature. 5 ~ 60 minutes)

User shall set whether to use or not to use sterilization mode.

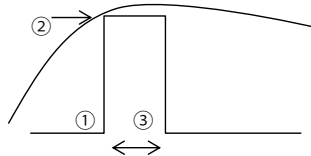

3-5. Service setup

44. Pump maximum speed

Initial setting: Varies according to model

Normally setting is not necessary.
Adjust when needed to reduce the pump sound, etc.
Besides that, the unit has Air Purge function.

When the Pump flow setting is Max. Duty, this duty setting is the duty of fixed pump that runs during operation.

| | | |
|---------------|----------|------------------|
| Service setup | | 12:00 pm, Mon |
| Flow rate | Max Duty | Operation |
| 45.6 L/min. | 0xCE | Air purge |
| Select | | |

45. Dry concrete

Operate concrete curing operation.
Select Edit and set the temperature for every stage (1~99 1 is for 1 day).
Setting range is 25~55°C

When it is turned ON, dry concrete starts.

In the case of 2 zones, it dries both zones.

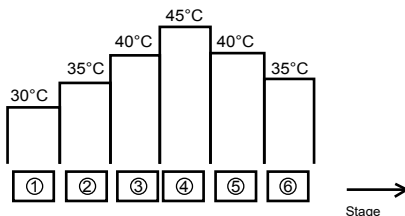

46. Service contact

Able to set the name & telephone no. of contact person when there is breakdown etc. or client has trouble. (2 items)

| | |
|------------------|---------------|
| Service setup | 12:00 pm, Mon |
| Service contact: | |
| | Contact 1 |
| | Contact 2 |
| ▲ Select | [←] Confirm |

| | |
|-------------------------------------|-------------|
| Contact - 1: Brian Adams | |
| ABC/abc | 0-9/ Other |
| A B C D E F G H I J K L M N O P Q R | |
| S T U V W X Y Z a b c d e f g h i | |
| j k l m n o p q r s t u v w x y z | |
| ▼ Select | [←] Confirm |

3-6. Remote control setup

47. RC selection

Initial setting: Single

If there is only one remote controller, set to "Single".
If two remote controllers are installed, set to "Dual".

For details on the Dual setting, refer to the instruction manual of the optional remote controller.

| | |
|--------------|---------------|
| RC selection | 12:00 pm, Mon |
| | Single |
| | Dual |
| ▼ Select | [←] Confirm |

3 Service and maintenance

If forget Password and cannot operate remote controller

← + ↩ + > Press for 5 seconds.

Password unlock screen appears, press Confirm and it shall reset. Password will become 0000. Please reset it again.

Note: This is displayed only when the remote controller is password-locked.

Maintenance menu

How to set up the Maintenance menu

| | |
|-----------------------|---------------|
| Maintenance menu | 12:00 pm, Mon |
| Actuator check | |
| Test mode | |
| Sensor setup | |
| Reset password | |
| ▼ Select | [↩] Confirm |

← + ↩ + > Press for 5 seconds.

Items that can be set

- ① Actuator check (Manual ON/OFF all functional parts)
Note: As there is no protection action, be careful not to cause any error when operating each part (do not turn ON pump when there is no water etc.)
- ② Test mode (Test run)
Normally it is not used.
- ③ Sensor setup (offset gap of detected temp of each sensor can be set within -3~3°C range)
Note: Use only when sensor is deviated. It affects temperature control.
- ④ Reset password (password reset)

Custom menu

How to set up a Custom menu

| | |
|-------------------------|---------------|
| Custom menu | 12:00 pm, Mon |
| Cool mode | |
| Back-up heater | |
| Reset energy monitor | |
| Reset operation history | |
| ▼ Select | [↩] Confirm |

| | |
|-------------------------|---------------|
| Custom menu | 12:00 pm, Mon |
| Back-up heater | |
| Reset energy monitor | |
| Reset operation history | |
| Anti-stick mode | |
| ▲ Select | [↩] Confirm |

≡ + √ + < Press for 5 seconds.

Items that can be set

- ① Cool mode (Select Cooling function: Enable/Disable) Default is Disable.
Note: As Enable/Disable Cool mode may affect electricity application, be careful and do not simply change it. In Cool mode, be careful if piping is not insulated properly, dew may form on pipe and water may drip on the floor and damage the floor.
- ② Back-up heater (Select Back-up heater: Enable/Disable)
Note: This back-up heater refers to the Extra heater. Differs from the use/non-use of back-up heater that is set by the customer. (This setting should only be used if requested by the utility company.) Installation must be carried out under the responsibility of the person in charge of installation.
- ③ Reset energy monitor (delete memory of Energy monitor).
Use this when moving house and handover the unit.
- ④ Reset operation history (delete memory of operation history)
Use this when moving house and handover the unit.
- ⑤ Anti-stick mode (select Anti-stick mode: Enable/Disable)
Default is Anti-stick mode Enable.
The actuator is regularly activated every Monday at 3:00 am to prevent the actuating parts from sticking together.
Select Disable if wish to stop the mode being activated periodically.
Parts and other components that may not operate if Disable is selected may stick if not operated for a long period of time.